

Contents

MOTORCYCLE SAFETY.....	1
Important Safety Information.....	2
Important Safety Precautions.....	2
Accessories & Modifications.....	3
Safety Labels.....	4
INSTRUMENTS & CONTROLS.....	5
Operation Component Locations.....	6
Indicator.....	7
MIL Blink Pattern.....	7
Current DTC/Freeze DTC.....	7
Circuit Inspection.....	8
DTC Index.....	9
BEFORE RIDING.....	11
Are You Ready to Ride?.....	12
Is Your Motorcycle Ready to Ride?.....	13
Pre-ride Inspection.....	13
BASIC OPERATING INSTRUCTIONS.....	15
Safe Riding Precautions.....	16
Starting & Stopping the Engine.....	17
Fast Idle Knob.....	17
Preparation.....	17
Starting Procedure.....	17
How to Stop the Engine.....	18
Break-in Guidelines.....	19

SERVICING YOUR HONDA.....	21
<i>Before You Service Your Honda</i>	
The Importance of Maintenance.....	22
Maintenance Safety.....	23
Important Safety Precautions.....	23
Maintenance Schedule.....	24
General Competition Maintenance.....	26
Before & After Competition Maintenance.....	30
Between Motos & Practice Maintenance.....	30
After Competition Maintenance.....	30
<i>Service Preparations</i>	
Maintenance Component Locations.....	32
Seat.....	33
Fuel Tank.....	34
Subframe.....	36
<i>Service Procedures</i>	
<u>Fluids & Filters</u>	
Fuel System.....	40
Engine Oil.....	45
Transmission Oil.....	48
Coolant.....	50
Air Cleaner.....	52
Crankcase Breather.....	54
<u>Engine</u>	
Throttle.....	55
Engine Idle Speed.....	57
Clutch System.....	58
Spark Plug.....	63
Valve Clearance.....	64
Piston/Piston Rings/Piston Pin.....	73

<u>Chassis</u>	
Suspension.....	83
Brakes.....	87
Wheels.....	91
Tires & Tubes.....	92
Drive Chain.....	94
Exhaust Pipe/Muffler.....	97
Steering Damper.....	100
Additional Maintenance Procedures.....	103
Appearance Care.....	105

ADJUSTMENTS FOR COMPETITION ...107
Front Suspension Adjustments.....108
 Front Suspension Air Pressure.....108
 Front Suspension Damping109
 Fork springs109
 Front Suspension Disassembly110
 Damper Oil Change113
 Fork Assembly116
Rear Suspension Adjustments122
 Rear Suspension Spring Pre-Load.....122
 Rear Suspension Damping.....123
 Rear Suspension Race Sag124
Suspension Adjustments for Track
 Conditions126
 Suspension Adjustment Guidelines.....127
 Tuning Tips130
 Spark Plug Reading130
Steering Damper Adjustment131
 Steering Damper Damping131
Steering Damper Adjustment Guidelines.....132
Chassis Adjustments.....133
 Rear End133
 Fork Height/Angle133
 Wheelbase133
Gearing134
Tire Selection for Track Conditions.....135
Personal Fit Adjustments136
 Control Positioning.....136
 Handlebar Position, Width & Shape.....136

TIPS137
Transporting Your Motorcycle138
Storing Your Honda.....139
 Preparation for Storage139
 Removal from Storage139
You & the Environment140
Troubleshooting.....141

TECHNICAL INFORMATION143
Vehicle Identification144
 Serial Numbers144
Specifications145
Torque Specifications.....146
 Nuts, Bolts, Fasteners146
Oxygenated Fuels.....149
Competition Logbook150
Optional Parts List152
Spare Parts & Equipment.....153
 Spare Parts153
 General Tools153
 Honda Special Tools153
 Chemical Products153
 Other Products153
Wiring Diagram.....154

CONSUMER INFORMATION155
Authorized Manuals156
Contacting Honda.....157
Your Honda Dealer.....158
The Honda Rider's Club (USA only)159

INDEX160

QUICK REFERENCE

**2010
Honda CRF450R
OWNER'S MANUAL & COMPETITION HANDBOOK**

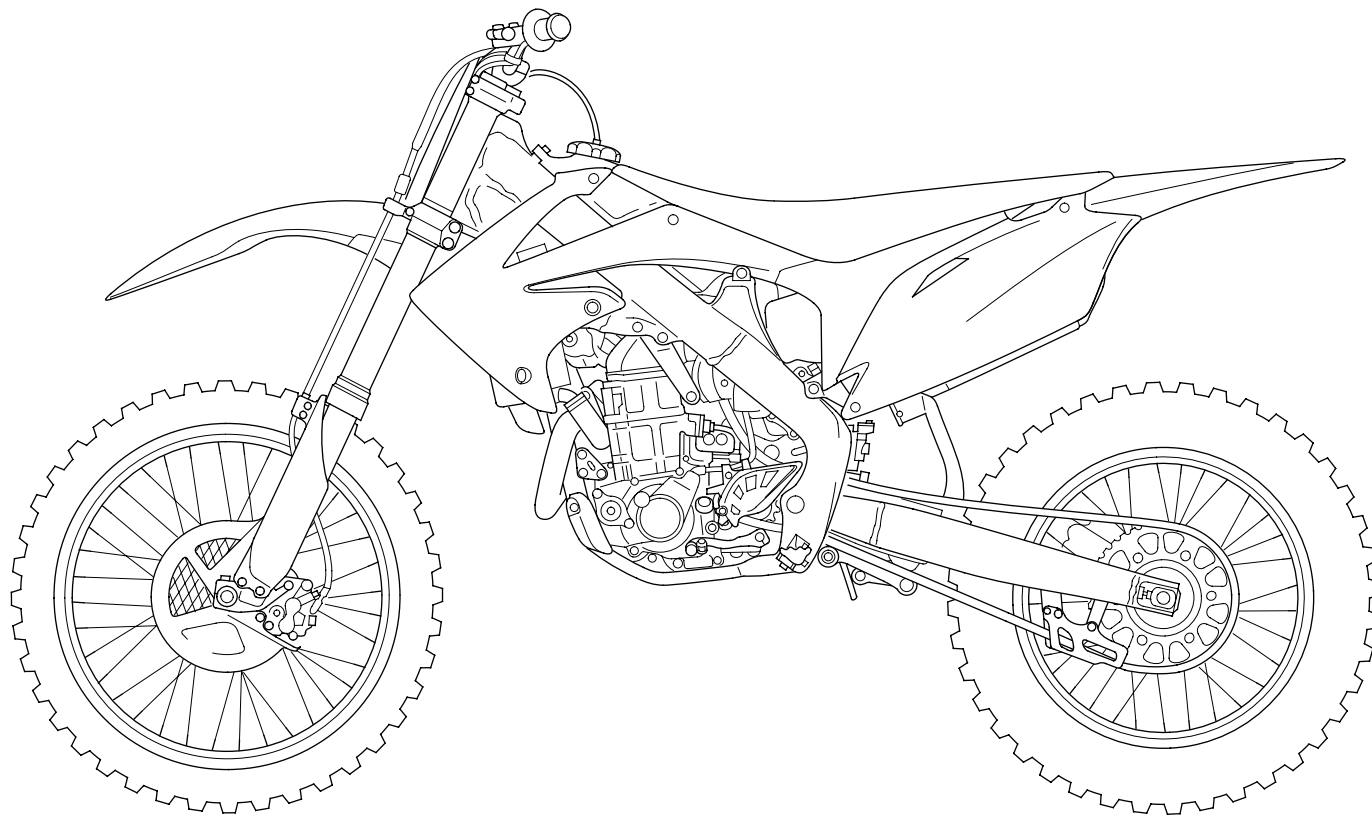

Introduction

Congratulations on choosing your Honda CRF motocross motorcycle.

When you own a Honda, you're part of a worldwide family of satisfied customers – people who appreciate Honda's reputation for building quality into every product.

Your CRF is a high performance racing motorcycle that utilizes the latest motocross technology and is intended for competition use in sanctioned, closed-course events by experienced riders only.

Be aware that motocross is a physically demanding sport that requires more than just a fine motorcycle. To do well, you must be in excellent physical condition and be a skillful rider. For the best results, work diligently on your physical conditioning and practice frequently.

Before riding, take time to get acquainted with your CRF and how it works. To protect your investment, we urge you to take responsibility for keeping your CRF well maintained. Scheduled service is a must, of course. But it's just as important to observe the break-in guidelines, and perform all the pre-ride and other periodic checks detailed in this manual.

You should also read the owner's manual before you ride. It's full of facts, instructions, safety information, and helpful tips. To make it easy to use, the manual contains a table of contents, a detailed list of topics at the beginning of each section, and an index at the back of the book.

As you read this manual, you will find information that is preceded by a **NOTICE** symbol. This information is intended to help you avoid damage to your CRF, other property, or the environment.

Unless you are mechanically qualified and have the proper tools, you should see your Honda dealer for the service and adjustment procedures discussed in this manual.

An official Honda Service Manual for your CRF is available (page 156). It is the same manual your dealer uses. If you plan to do any service on your CRF beyond the standard maintenance procedures in this manual, you will find an official Honda Service Manual a valuable reference.

If you have any questions, or if you ever need a special service or repairs, remember that your Honda dealer knows your CRF best and is dedicated to your complete satisfaction.

Please report any change of address or ownership to your Honda dealer so we will be able to contact you concerning important product information.

You may also want to visit our website at www.honda.com

Happy riding!

California Proposition 65 Warning

WARNING: This product contains or emits chemicals known to the State of California to cause cancer and birth defects or other reproductive harm.

ABBREVIATION

Throughout this manual, the following abbreviations are used to identify the respective parts or system.

Abbrev. term	Full term
CKP sensor	Crankshaft Position sensor
DLC	Data Link Connector
DTC	Diagnostic Trouble Code
ECM	Engine Control Module
ECT sensor	Engine Coolant Temperature sensor
HPSD	Honda Progressive Steering Damper
IAT sensor	Intake Air Temperature sensor
MAP sensor	Manifold Absolute Pressure sensor
MIL	Malfunction Indicator Lamp
PGM-FI	Programmed Fuel Injection
TDC	Top Dead Center
TP sensor	Throttle Position sensor

A Few Words About Safety

Your safety, and the safety of others, is very important. And operating this motorcycle safely is an important responsibility.

To help you make informed decisions about safety, this manual contains a section devoted to *Motorcycle Safety*, as well as a number of Safety Messages throughout the manual.

Safety Messages are preceded by a safety alert symbol ▲ and one of three signal words: **DANGER**, **WARNING**, or **CAUTION**.

These signal words mean:

▲ DANGER

You **WILL** be **KILLED** or **SERIOUSLY HURT** if you don't follow instructions.

▲ WARNING

You **CAN** be **KILLED** or **SERIOUSLY HURT** if you don't follow instructions.

▲ CAUTION

You **CAN** be **HURT** if you don't follow instructions.

Of course, it is not practical or possible to warn you about all hazards associated with operating or maintaining a motorcycle. You must use your own good judgement.

This section presents some of the most important information and recommendations to help you ride your CRF safely. Please take a few moments to read these pages. This section also includes information about the location of safety labels on your CRF.

Important Safety Information.....	2
Important Safety Precautions.....	2
Accessories & Modifications	3
Safety Labels.....	4

Important Safety Information

Important Safety Precautions

Your CRF can provide many years of pleasure, if you take responsibility for your own safety and understand the challenges you can meet in competitive racing.

As an experienced rider, you know there is much you can do to protect yourself when you ride. The following are a few precautions we consider to be most important.

Never Carry a Passenger.

Your CRF is designed for one operator only. Carrying a passenger can cause an accident in which you and others can be hurt.

Wear Protective Gear.

Whether you're practicing to improve your skills, or riding in competition, always wear an approved helmet, eye protection, and proper protective gear.

Take Time to Get to Know Your CRF.

Because every motorcycle is unique, take time to become thoroughly familiar with how this one operates and responds to your commands before placing your machine, and yourself, in competition.

Learn and Respect Your Limits.

Never ride beyond your personal abilities or faster than conditions warrant. Remember that alcohol, drugs, illness and fatigue can reduce your ability to perform well and ride safety.

Don't Drink and Ride.

Alcohol and riding don't mix. Even one drink can reduce your ability to respond to changing conditions, and your reaction time gets worse with every additional drink. So don't drink and ride, and don't let your friends drink and ride either.

Keep your Honda in Safe Condition.

Maintaining your CRF properly is critical to your safety. A loose bolt, for example, can cause a breakdown in which you can be seriously injured.

Accessories & Modifications

Installing non-Honda accessories, removing original equipment, or modifying your CRF in any way that would change its design or operation, could seriously impair your CRF's handling, stability, and braking, making it unsafe to ride.

WARNING

Improper accessories or modifications can cause a crash in which you can be seriously hurt or killed.

Follow all instructions in this owner's manual regarding modifications and accessories.

Safety Labels

Read these labels carefully and don't remove them.

If a label comes off or becomes hard to read, contact your Honda dealer for replacement.

(For Canada)

THIS COMPETITION VEHICLE IS FOR USE EXCLUSIVELY IN CLOSED-COURSE COMPETITION AND IS NOT INTENDED FOR USE ON PUBLIC HIGHWAYS.
CE VÉHICULE DE COMPÉTITION EST DESTINÉ À ÊTRE UTILISÉ EXCLUSIVEMENT DANS LES COURSES EN CIRCUIT FERMÉ ET N'EST PAS DESTINÉ AUX VOIES PUBLIQUES.

IMPORTANT INFORMATION

Operator only. No passengers. This Honda Motorcycle is sold as is without warranty, and the entire risk as to quality and performance is with the buyer. Read owner's manual.

This vehicle is designed, manufactured and sold for competition use only. It does not conform to Federal Motor Vehicle Safety Standards or U.S. EPA Noise and Emissions Standards. Operation on public streets, roads, highways or for off-road recreation is illegal.

State and Federal laws prohibit operation of this vehicle except in an organized racing or competitive event on a closed course. Or by permit issued by the local governmental agency having jurisdiction.

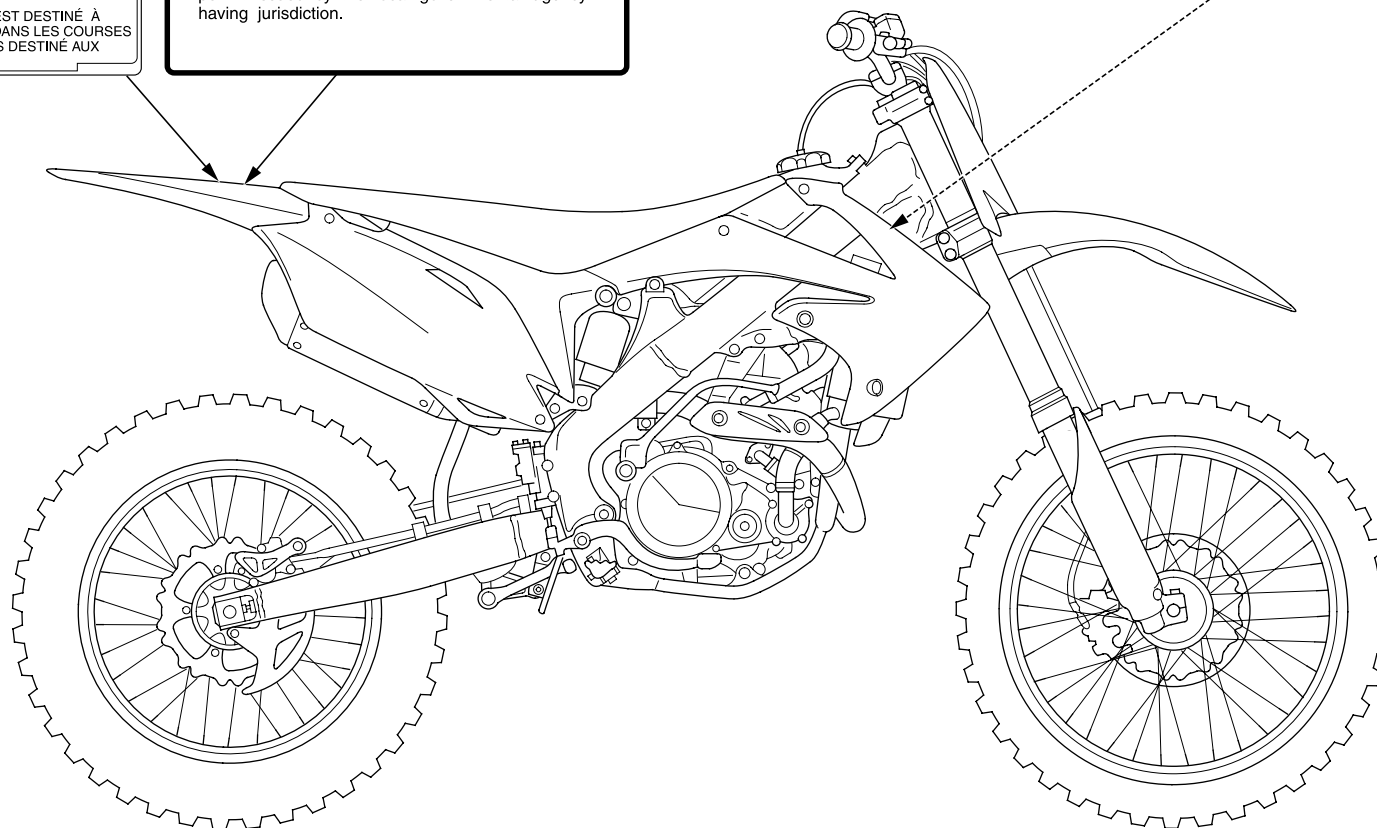

Read this section carefully before you ride. It presents the location of the basic controls on your CRF.

Operation Component Locations	6
Indicator	7
MIL Blink Pattern	7
Current DTC/Freeze DTC	7
Circuit Inspection.....	8
DTC Index	9

Operation Component Locations

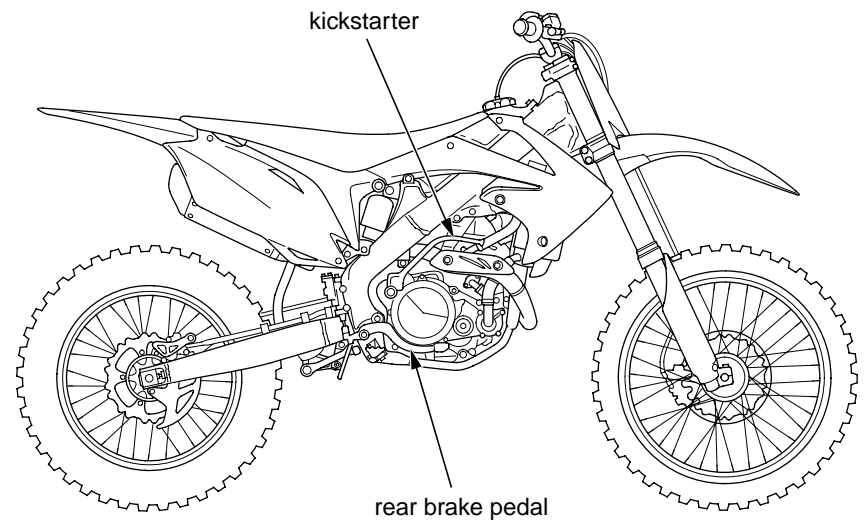
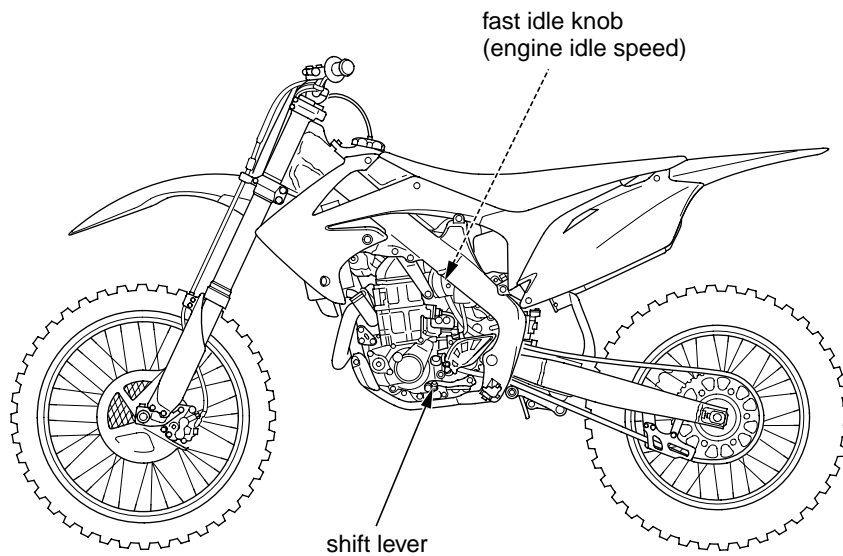
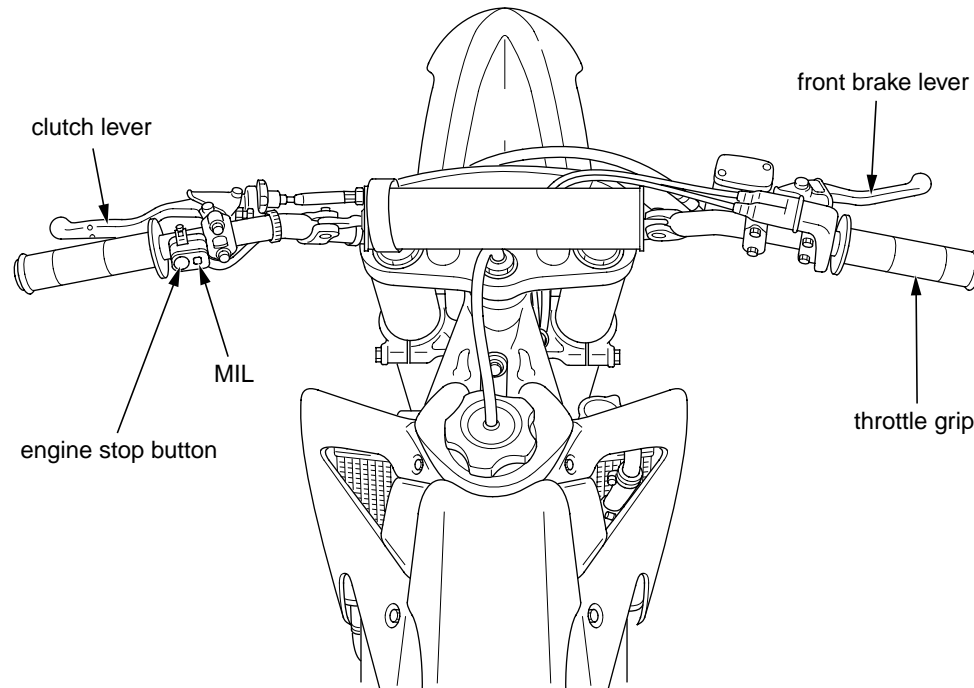

The MIL on your CRF keeps you informed, alerts you to possible problems, and makes your riding safer and more enjoyable. Refer to the MIL frequently.

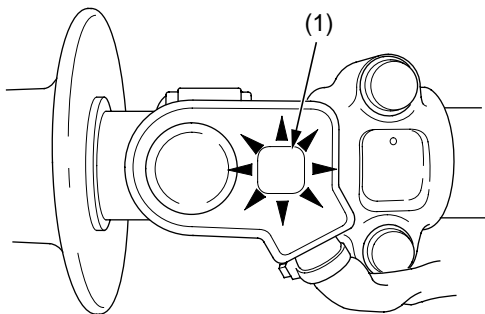

(1) MIL

The MIL flashes when there is any abnormality in the PGM-FI system. It should also light for a few seconds and then go off when the engine is started.

If the MIL comes on at any other time, reduce speed and refer to an official Honda Service Manual available for purchase from your Honda dealer (page 156).

If the MIL does not come on when it should, have your Honda dealer check it for problems.

MIL Blink Pattern

The MIL will blink the appropriate DTC number if the ECM detects an active problem while the engine is running at less than 4,000 rpm. The MIL will stay on when engine speed is over 4,000 rpm.

The MIL has two types of blinks: a long blink and short blink. The long blinking lasts for 1.2 seconds, the short blinking lasts for 0.4 seconds. One long blink is the equivalent of ten short blinks. For example, when one long blink is followed by two short blinks, the MIL is 12 (one long blink = 10 blinks, plus two short blinks).

When the ECM stores more than one DTC, the MIL will indicate them by blinking in the order from the lowest number to highest number.

Current DTC/Freeze DTC

The DTC is indicated in two ways according to the failure status.

- In the case that the ECM detects an active problem, the MIL will come on and will start to blink the DTC when the engine is started.
- In the case that the ECM does not detect an active problem but has recorded a previous problem in its memory, the MIL will not come on. If it is necessary to retrieve any past problems stored in the memory, refer to an official Honda Service Manual.

Indicator

Circuit Inspection

Always clean around the ECM and keep debris away from the connectors before disconnecting them.

A faulty PGM-FI system is often related to poorly connected or corroded connections. Check the following connections.

- (1) MAP sensor connector
- (2) ECT sensor connector
- (3) TP sensor connector
- (4) IAT sensor connector
- (5) Injector connector
- (6) No.1/No.2 CKP sensor connector
- (7) ECM connector

Remember, circuit inspection is not a “cure-all” for other problems in your engine’s PGM-FI system.

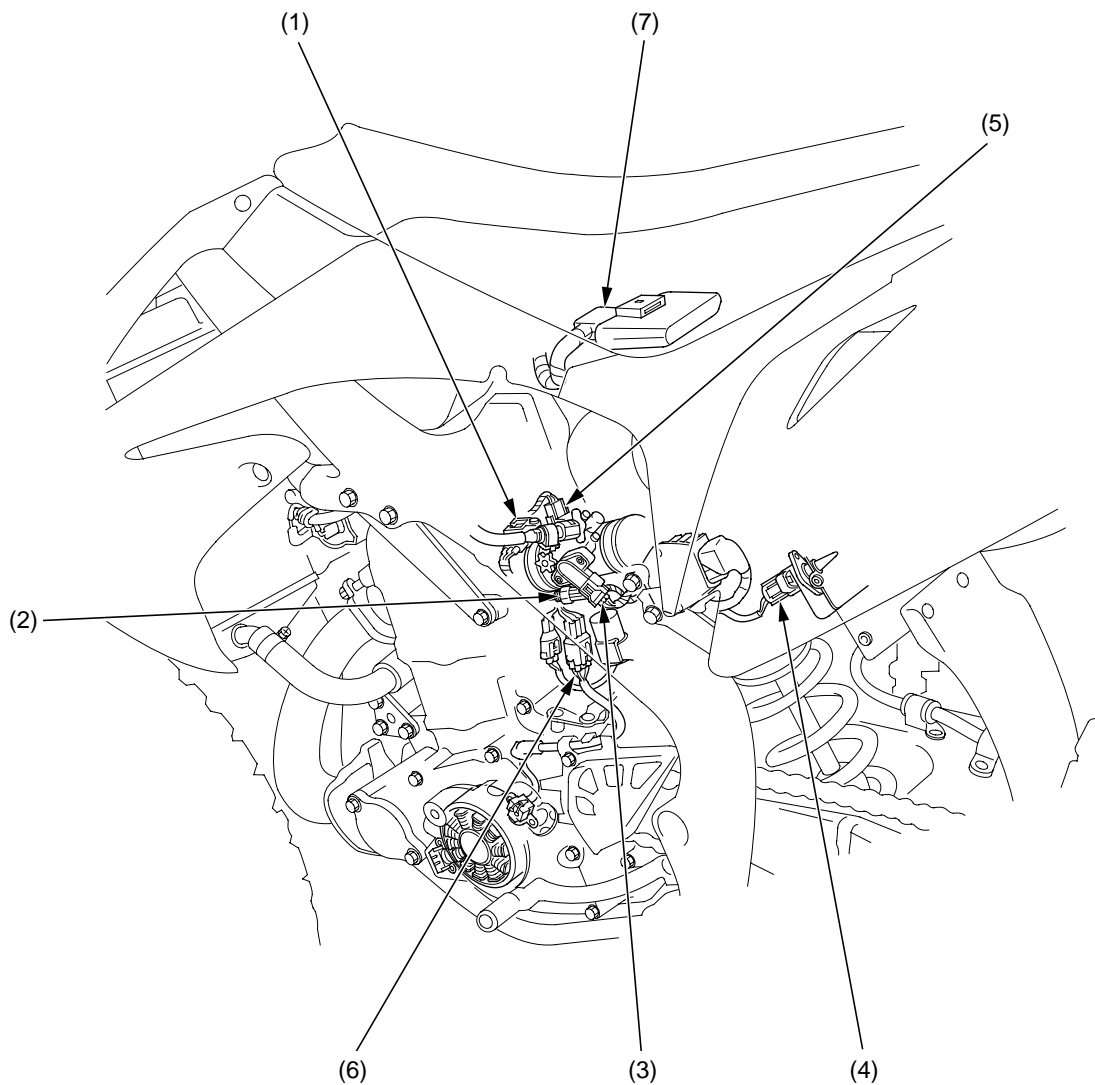

DTC Index

Refer to MIL Blink Pattern on page 7.

MIL blinks	Function Failure	Symptom/Fail-safe function
1	MAP sensor circuit malfunction	Engine operates normally
2	MAP sensor performance problem	Engine operates normally
7	ECT sensor circuit malfunction	Hard start at a low temperature
8	TP sensor circuit malfunction	Poor engine acceleration
9	IAT sensor circuit malfunction	Engine operates normally
12	Injector circuit malfunction	<ul style="list-style-type: none"> • Engine does not start • Injector, fuel pump and ignition shut down
19	No.1 CKP sensor circuit malfunction	<ul style="list-style-type: none"> • Engine does not start • Injector, fuel pump and ignition shut down
69	No.2 CKP sensor circuit malfunction	<ul style="list-style-type: none"> • Engine does not start • Injector, fuel pump and ignition shut down

Should be serviced by your dealer, unless the owner has proper tools and is technically qualified.
 The series of 12, 19, and 69 MIL blinks cannot be checked because the engine cannot be started.
 If the engine does not start, check all connector connections and/or refer to an official Honda Service Manual (page 156) for troubleshooting of the PGM-FI symptom.

Before each ride, you need to make sure you and your CRF are both ready to ride. To help get you prepared, this section discusses how to evaluate your riding readiness, and what items you should check on your CRF.

For information about suspension, steering damper, and other adjustments, see page 107.

Are You Ready to Ride?.....	12
Is Your Motorcycle Ready to Ride?.....	13
Pre-ride Inspection.....	13

Are You Ready to Ride?

Before riding your CRF for the first time, we strongly recommend that you read this owner's manual, make sure you understand the safety messages, and know how to operate the controls.

Before each ride, it's also important to make sure you and your CRF are both ready to ride.

For information about suspension, steering damper, and other adjustments, see page 107.

Whether you're preparing for competition or for practice, always make sure you are:

- In good physical and mental condition
- Free of alcohol and drugs
- Wearing an approved helmet, eye protection, and other appropriate riding gear

Although complete protection is not possible, wearing the proper gear can reduce the chance or severity of injury when you ride.

WARNING

Not wearing a helmet increases the chance of serious injury or death in a crash.

Be sure you always wear a helmet, eye protection and other protective apparel when you ride.

Competitive riding can be tough on a motorcycle, so it's important to inspect your CRF and correct any problems you find before each ride. Check the following items (page numbers are at the right):

⚠ WARNING

Improperly maintaining this motorcycle or failing to correct a problem before riding can cause a crash in which you can be seriously hurt or killed.

Always perform a pre-ride inspection before every ride and correct any problems.

Pre-ride Inspection

Check the following before each ride:

- Engine oil level.....46
- Transmission oil level.....49
- Fuel line for condition40
- Coolant for proper level..... 50
- Cooling system and hoses for condition.....51
- Spark plug for proper heat range, carbon fouling and spark plug wire terminal for looseness63
- Air cleaner for condition and contamination.....52
- Clutch lever adjustment and freeplay58
- Breather drain for cleaning54
- Steering head bearing and related parts for condition.....103
- Steering damper operation.....100
- Throttle operation55
- Tires for damage or improper inflation pressure92
- Spokes for looseness.....91
- Rim locks for looseness.....91
- Front and rear suspension for proper operation83, 84
- Front and rear brakes, check operation87
- Drive chain for correct slack and adequate lubrication94, 95
- Drive chain sliders and drive chain rollers for damage or wear94, 95
- Exhaust pipe/Muffler for looseness97
- Every possible part for looseness (such as cylinder head nuts, engine mounting bolts/nuts, axle nuts, handlebar holder bolts, fork bridge pinch bolts, drive chain adjuster, drive chain guide, wire harness connectors, kickstarter mounting bolt)146-148
- Indicator7

This section gives basic information on how to start and stop your engine as well as break-in guidelines.

Safe Riding Precautions.....16
Starting & Stopping the Engine17
Fast Idle Knob17
Preparation17
Starting Procedure17
How to Stop the Engine.....18
Break-in Guidelines19

Basic Operating Instructions

Safe Riding Precautions

Before riding your CRF for the first time, please review the *Important Safety Precautions* beginning on page 2 and the previous section, titled *Before Riding*.

For your safety, avoid starting or operating the engine in an enclosed area such as a garage. Your CRF's exhaust contains poisonous carbon monoxide gas which can collect rapidly in an enclosed area and cause illness or death.

Always follow the proper starting procedure described below.

Your CRF can be kickstarted with the transmission in gear by pulling in the clutch lever before operating the kickstarter.

Fast Idle Knob

The fast idle knob has two functions:

- When pulled out, the fast idle knob assists in first-time start-up for cold weather starting.
- When pushed in, it acts as an idle adjustment screw. Refer to *Idle Speed Adjustment* on page 57.

Preparation

Make sure that the transmission is in neutral.

Starting Procedure

Always follow the proper starting procedure described as follow.

Check the engine oil, transmission oil and coolant levels before starting the engine (pages 46, 49, 50).

Cold Engine Starting

1. Shift the transmission into neutral.
2. If the temperature is 95°F (35°C) or below, pull the fast idle knob (1) fully out.

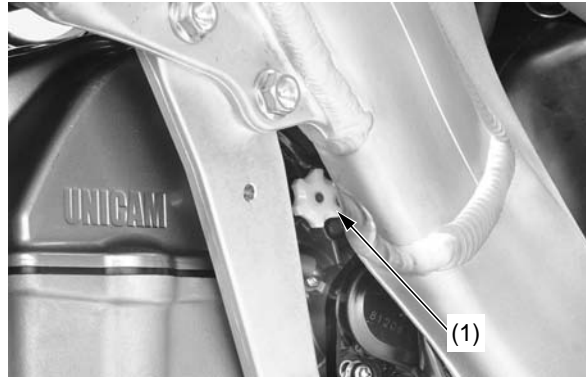

(1) fast idle knob

3. With the throttle closed, operate the kickstarter starting from the top of the kickstarter stroke, kick through to the bottom with a rapid, continuous motion.
4. About a minute after the engine starts, push the fast idle knob back all the way to fully OFF.
If idling is unstable, open the throttle slightly.

Warm Engine Starting

1. Shift the transmission into neutral.
2. Kick-start the engine. (Do not open the throttle.)

If Difficult to Start After Stalling

1. Shift the transmission into neutral.
2. With the throttle fully opened, repeat kickstarter operation approximately 10 times to discharge excessive fuel from the engine.
3. Kick-start the engine. (Do not open the throttle.)

Starting & Stopping the Engine

How to Stop the Engine

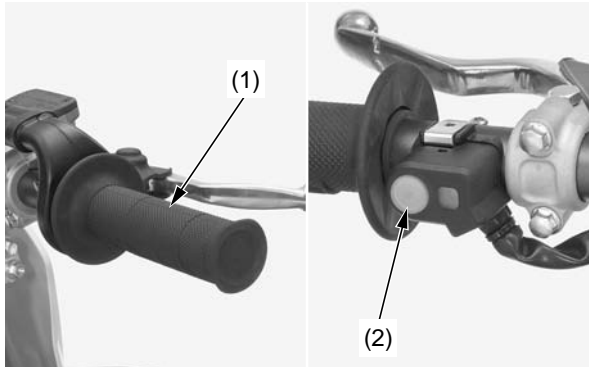

(1) throttle

(2) engine stop button

Normal Engine Stop

1. Shift the transmission into neutral.
2. Lightly open the throttle (1) two or three times, and then close it.
3. Push and hold the engine stop button (2) until the engine stops completely.

Emergency Engine Stop

To stop the engine in an emergency, push and hold the engine stop button.

Help assure your CRF's future reliability and performance by paying extra attention to how you ride during the first operating day or 15 miles (25 km).

During this period, avoid full-throttle starts and rapid acceleration.

This same procedure should be followed each time when:

- piston is replaced
- piston rings are replaced
- cylinder is replaced
- crankshaft or crank bearings are replaced

Keeping your CRF well maintained is absolutely essential to your safety. It's also a good way to protect your investment, get maximum performance, avoid breakdowns, and have more fun.

To help keep your CRF in good shape, this section includes a Maintenance Schedule for required servicing and step-by-step instructions for specific maintenance tasks. You'll also find important safety precautions, information on oils, and tips for keeping your CRF looking good.

An ECM system is used on this motorcycle; consequently, routine ignition timing adjustment is unnecessary. If you want to check the ignition timing, refer to the Honda Service Manual (page 156).

An optional tool kit may be available. Check with your Honda dealer's parts department.

Before You Service Your Honda

The Importance of Maintenance	22
Maintenance Safety	23
Important Safety Precautions.....	23
Maintenance Schedule	24
General Competition Maintenance	26
Before & After Competition Maintenance.....	30
Between Motos & Practice Maintenance	30
After Competition Maintenance	30

Service Preparations

Maintenance Component Locations.....	32
Seat	33
Fuel Tank	34
Subframe	36

Service Procedures

Fluids & Filters

Fuel System	40
Engine Oil	45
Transmission Oil	48
Coolant	50
Air Cleaner	52
Crankcase Breather	54

Engine

Throttle	55
Engine Idle Speed	57
Clutch System	58
Spark Plug	63
Valve Clearance.....	64
Piston/Piston Rings/Piston Pin.....	73

Chassis

Suspension.....	83
Front Suspension Inspection	83
Rear Suspension Inspection	84
Recommended Fork Oil.....	85
Fork Oil Change.....	85
Brakes.....	87
Wheels.....	91
Tires & Tubes.....	92
Drive Chain	94
Exhaust Pipe/Muffler	97
Steering Damper.....	100
Additional Maintenance Procedures	103
Appearance Care	105

The Importance of Maintenance

Keeping your CRF well-maintained is absolutely essential to your safety. It's also a good way to get maximum performance during each moto. Careful pre-ride inspections and good maintenance are especially important because your CRF is designed to be ridden in off-road competition.

Remember, proper maintenance is your responsibility. Be sure to inspect your CRF before each ride and follow the Maintenance Schedule in this section.

WARNING

Improperly maintaining this motorcycle or failing to correct a problem before you ride can cause a crash in which you can be seriously hurt or killed.

Always follow the inspection and maintenance recommendations and schedules in this owner's manual.

This section includes instructions on how to perform some important maintenance tasks. Some of the most important safety precautions follow. However, we cannot warn you of every conceivable hazard that can arise in performing maintenance. Only you can decide whether or not you should perform a given task.

WARNING

Failure to properly follow maintenance instructions and precautions can cause you to be seriously hurt or killed.

Always follow the procedures and precautions in this owner's manual.

Important Safety Precautions

- Make sure the engine is off before you begin any maintenance or repairs. This will help eliminate several potential hazards:

Carbon monoxide poisoning from engine exhaust. Be sure there is adequate ventilation whenever you operate the engine.

Burns from hot motorcycle parts. Let the engine and exhaust system cool before touching.

Injury from moving parts. Do not run the engine unless instructed to do so.

- Read the instructions before you begin, and make sure you have the tools and skills required.
- To help prevent the motorcycle from falling over, park it on a firm, level surface, using an optional workstand or a maintenance stand to provide support.
- To reduce the possibility of a fire or explosion, be careful when working around gasoline. Use only a non-flammable (high flash point) solvent such as kerosene—not gasoline—to clean parts. Keep cigarettes, sparks, and flames away from all fuel-related parts.

Maintenance Schedule

To maintain the safety and reliability of your CRF, regular inspection and service is required as shown in the Maintenance Schedule that follows.

The Maintenance Schedule list items that can be performed with basic mechanical skills and hand tools. Procedures for these items are provided in this manual.

The Maintenance Schedule also includes items that involve more extensive procedures and may require special training, tools, and equipment. Therefore, we recommend that you have your Honda dealer perform these tasks unless you have advanced mechanical skills and the required tools. Procedures for items in this schedule are provided in an official Honda Service Manual available for purchase from your Honda dealer (page 156).

Service intervals in the maintenance schedule are expressed in terms of races and riding hours. To avoid overlooking required service, we urge you to develop a convenient way to record the number of races and/or hours you ride.

If you do not feel capable of performing a given task or need assistance, remember that your Honda dealer knows your CRF best and is fully equipped to maintain and repair it. If you decide to do your own maintenance, use only Honda Genuine Parts or their equivalents for repair or replacement to ensure the best quality and reliability.

Perform the pre-ride inspection (page 13) at each scheduled maintenance period.

Summary of Maintenance Schedule Notes and Procedures:

Notes:

1. Clean after every moto for dusty riding condition.
2. Replace every 2 years. Replacement requires mechanical skill.
3. Replace after the first break-in ride.
4. Inspect after the first break-in ride.
5. Replace the transmission oil, if the clutch discs and plates are replaced.
6. Replace every year.

Maintenance Procedures:

I: inspect and clean, adjust, lubricate or replace if necessary

C: clean

A: adjust

L: lubricate

R: replace

Maintenance Schedule

Perform the Pre-ride Inspection (page 13) at each scheduled maintenance period.

I: Inspect and Clean, Adjust, Lubricate or Replace if necessary. C: Clean. A: Adjust. L: Lubricate. R: Replace.

FREQUENCY	NOTE	Each race or about 2.5 hours	Every 3 races or about 7.5 hours	Every 6 races or about 15.0 hours	Every 9 races or about 22.5 hours	Every 12 races or about 30.0 hours	Ref. Page
ITEMS							
FUEL LINE	(NOTE 6)	I				R	40
THROTTLE OPERATION		I					56
AIR FILTER	(NOTE 1)	C					52
CRANKCASE BREATHER		I					54
SPARK PLUG		I					63
VALVE CLEARANCE	(NOTE 4)			I			64-72
ENGINE OIL	(NOTE 3)	I		R			45
ENGINE OIL FILTER	(NOTE 3)			R			46
ENGINE IDLE SPEED		I					57
PISTON AND PISTON RINGS				R			73
PISTON PIN						R	76
TRANSMISSION OIL	(NOTE 5)	I		R			48
RADIATOR COOLANT	(NOTE 2)	I					50
COOLING SYSTEM		I					50
DRIVE CHAIN		I, L	R				94
DRIVE CHAIN SLIDER		I					94
DRIVE CHAIN ROLLER		I					95
DRIVE SPROCKET		I					96
DRIVEN SPROCKET		I					96
BRAKE FLUID	(NOTE 2)	I					88
BRAKE PADS WEAR		I					90
BRAKE SYSTEM		I					87
CLUTCH SYSTEM	(NOTE 5)	I					58
CONTROL CABLES		I, L					103
EXHAUST PIPE/MUFFLER		I					97
SUSPENSION		I					83, 84
SWINGARM/SHOCK LINKAGE			L				29, 84
FORK OIL EXCEPT DAMPER	(NOTE 3)		R				85
FORK OIL DAMPER					R		113
NUTS, BOLTS, FASTENERS		I					104, 146-148
WHEELS/TIRES		I					91-93
STEERING HEAD BEARINGS					I		103

WE RECOMMENDED THESE ITEMS BE SERVICED BY REFERRING TO AN OFFICIAL HONDA SERVICE MANUAL.

This maintenance schedule is based upon average riding condition. Machine subjected to severe use require more frequent servicing.

- NOTE:
- 1.Clean after every moto for dusty riding condition.
 - 2.Replace every 2 years. Replacement requires mechanical skill.
 - 3.Replace after the first break-in ride.
 - 4.Inspect after the first break-in ride.
 - 5.Replace the transmission oil, if the clutch discs and plates are replaced.
 - 6.Replace every year.

General Competition Maintenance

Perform maintenance on firm, level ground using an optional workstand, or equivalent support.

When tightening bolts, nuts or screws, start with the larger diameter or inner fasteners, and tighten them to the specified torque using a crisscross pattern.

Use Honda Genuine Parts or their equivalent when servicing your CRF.

Clean parts in non-flammable (high flash point) cleaning solvent (such as kerosene) when disassembling. Lubricate any sliding surface, O-rings, and seals before reassembling. Grease parts by coating or filling where specified.

After any engine disassembly, always install new gaskets, O-rings, cotter pins, piston pin clips, snap rings, etc. when reassembling. After reassembly, check all parts for proper installation and operation.

All Pre-ride Inspection Items

Refer to *Pre-ride Inspection* page 13.

General Competition Maintenance

Spark Plug

Some non-resistor plugs may cause ignition problems. Refer to the recommendations elsewhere in this manual for specific types so you will be sure to use the proper reach and heat range. Replace periodically as specified in the Maintenance Schedule (page 25).

Spark Plug Cap

Install a small plastic tie-wrap around the spark plug cap to reduce any possibility of it loosening or of water penetration.

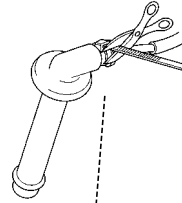

Air Cleaner

Clean and oil your air cleaner regularly because the volume of air able to pass through it has a great effect on performance. Both engine performance and long term durability may be affected by an air cleaner that has deteriorated and allows dirt to pass. Inspect the air cleaner closely each time it's serviced for evidence of small tears or seam separation. Keep a spare air cleaner oiled and ready to install, sealed in a plastic bag. Riding in dusty conditions may require servicing the air cleaner or replacing it with a pre-serviced air cleaner between motos. Be careful not to over oil the air cleaner. While it is important to oil the air cleaner thoroughly, over oiling will cause an overall rich running condition, probably more noticeable off idle and in low rpm performance. Follow the servicing instructions in the Maintenance section. Use Pro Honda Foam Filter Oil or an equivalent. Be sure to grease the air cleaner flange where it contacts the air cleaner housing. Pro Honda White Lithium Grease, or an equivalent, is handy for this because any dirt that penetrates this sealing area will show up clearly (page 52).

Use the Honda Genuine air cleaner or an equivalent air cleaner specified for your model.

Using the wrong Honda air cleaner or a non-Honda air cleaner which is not of equivalent quality may cause premature engine wear or performance problems.

Engine Oil and Filter

Drain and replace engine oil often to ensure the greatest service life of the piston, cylinder and crankshaft. Also replace engine oil filter often to ensure the greatest service life. Frequent changes will also assure consistent performance of power and response (page 46).

Transmission Oil

Drain and replace transmission oil often to ensure the greatest service life of the transmission and clutch. Frequent changes will also assure consistent performance of both shifting and clutch action (page 49).

Air Cleaner Housing Sealing

Remove and reseal the air cleaner housing boot where it connects to the air cleaner housing with Pro Honda Handgrip Cement or equivalent if there is any doubt to its sealing integrity. Inspect the air cleaner and air intake tract regularly for signs of deterioration or dirt penetration.

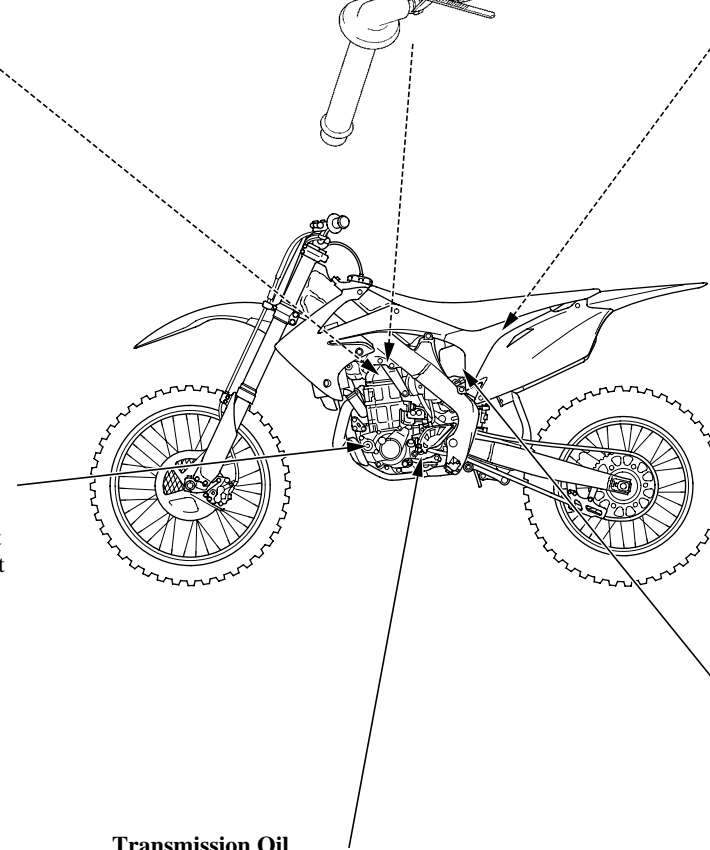

General Competition Maintenance

Handgrips

Always use Pro Honda Handgrip Cement when replacing handgrips.

Refer to an official Honda Service Manual (page 156) for installation instructions.

Throttle Grip

Right throttle grip: Align the index mark on the throttle grip with the index mark of the throttle pipe.

Left handlebar grip: Align the index mark on the left handlebar grip with the paint mark on the handlebar.

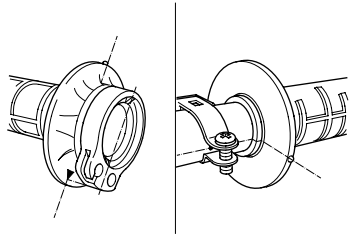

For added security, you may choose to bind the handgrips to the handlebar and throttle pipe with safety wires to prevent the possibility of them loosening. Position the twisted wire ends away from your palms and be sure to bend the wire ends well into the handgrip rubber so they will not snag your glove.

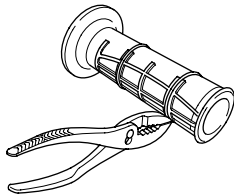

Throttle Control

Remove the throttle control every few rides, clean the inside of the throttle pipe and handlebar thoroughly. Inspect the cable carefully for kinks or other damage that may restrict throttle control in anyway. Move the handlebar from lock to lock to be sure there is no cable interference. Make certain the throttle operation is perfect after servicing and inspecting.

Gaskets

Always use new gaskets when reassembling components.

Cylinder head/Cylinder

Put a little grease on the dowel pins of the cylinder head and cylinder to prevent corrosion from dissimilar metals. The tolerances are quite tight, so it's important to keep these dowels absolutely clean (pages 73, 75).

Fuel Line

Refer to *Fuel System* on page 40.

Check the fuel line for deterioration, damage, or leakage.

Replace the fuel line every year.

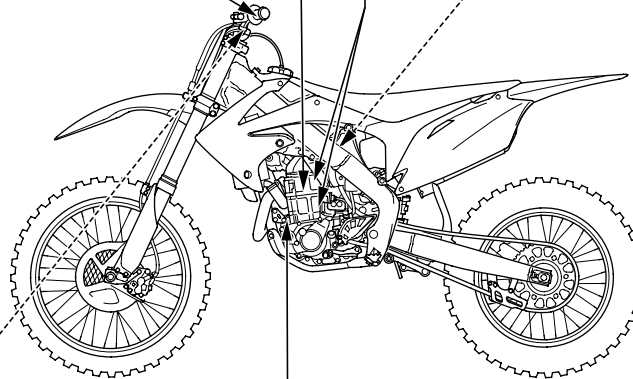

Electrical Connectors

Clean electrical connectors and wrap them with electrical tape to reduce the possibility of unwanted disconnections, water shorts or corrosion. Additional corrosion protection is offered by using Pro Honda Dielectric Grease on all electrical connections.

Engine Mounting Bolts and Nuts

Make sure the engine mounting bolts and nuts are tightened to the proper torque specification. For added peace of mind, remove the nuts, clean the threads, and apply Pro Honda Hondalock or an equivalent prior to torquing the nuts.

Suspension Linkage Lubrication

Disassemble, clean, inspect and lubricate all suspension linkage pivot bearings with grease after each 7.5 hours of running time in order to maintain proper suspension performance and minimize component wear.

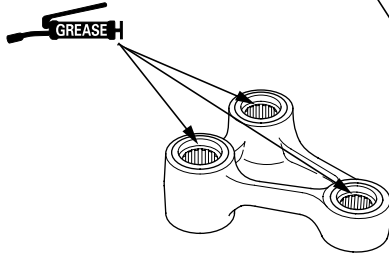

Swingarm Pivot Lubrication

Clean, inspect and lubricate the swingarm and suspension linkage pivots with grease. Be sure all of the dust seals are in good condition.

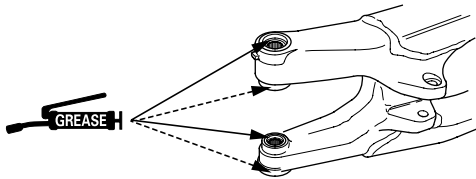

Swingarm

Do not attempt to weld or otherwise repair a damaged swingarm. Welding will weaken the swingarm.

Footpegs

Worn footpeg teeth can be repaired by filing the grooves between the teeth with a triangular shaped file. Be aware that filing them too sharp will reduce boot sole lifespan. Sharpen only the points of the teeth. Filing the grooves deeper will weaken the footpegs. Be sure the pegs are free to pivot freely and that the pivot pin retaining cotter pins are in good condition.

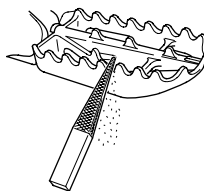

Brake Fluid Replacement

Refer to *Brake Pad Wear* in your Owner's Manual, page 90. **Brake Caliper Inspection:** Be sure both the front and rear calipers are able to move freely on the caliper pin and caliper bracket pins. Check pad thickness periodically and replace the pads when minimum thickness is reached. If the brakes fade when they are hot, inspect the pads for glazing or damage, and replace if necessary. **Brake Fluid Replacement:** Refer to an official Honda Service Manual (page 156) for brake fluid replacement instructions. Replace the brake fluid in the brake system every 2 years. Replace the fluid more frequently if you subject your brakes to severe use. Heavy braking heats the brake fluid and it may deteriorate sooner than expected. Any type of riding, that requires frequent use of the brakes, such as in tight woods, can shorten the service life of brake fluid.

Steering Head Bearings

Periodically clean, inspect and regrease the steering head bearings — especially if wet, muddy or extremely dusty courses are encountered often. Use urea based multi-purpose grease designed for high temperature, high pressure performance (example: EXCELITE EP2 manufactured by KYODO YUSHI, Japan or Shell Stamina EP2 or equivalent)

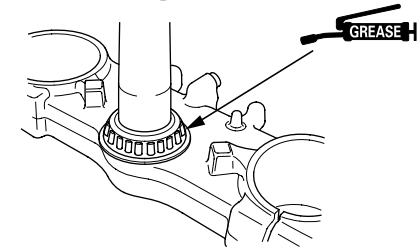

Fork Oil/Performance

Disassemble, clean and inspect the fork and replace the oil regularly. Contamination due to the tiny metal particles produced from the normal action of the fork, as well as normal oil breakdown, will deteriorate the performance of the suspension. Refer to an official Honda Service Manual (page 156). Use only KHL15-11 (KYB) which contains special additives to assure maximum performance of your CRF's front suspension.

Frame

Because your CRF is a high-performance machine, the frame should not be overlooked as part of your overall competition maintenance program. Periodically inspect the frame closely for possible cracking or other damage. It makes good racing sense.

Spokes

Check spoke tension frequently between the first few rides. As the spokes, spoke nuts and rim contact points seat-in, the spokes may need to be retightened. Once past this initial seating-in period, the spokes should hold their tension. Still, be sure your race maintenance program includes checking spoke tension and overall wheel condition on a regular basis (page 91).

Nuts, Bolts, Etc

Application of a thread locking agent to essential fasteners offers added assurance and security. Remove the nuts, clean the threads of both the nuts and bolts, apply Pro Honda Hondalock or an equivalent and tighten to the specified torque.

Bleed Hole

After every race, check the bleed hole below the water pump cover for leakage. Clean away any clogged dirt or sand, if necessary. Check for signs of seal leakage. If water leaks through the bleed hole, replace the mechanical seal. If oil leaks through the bleed hole, replace the oil seal. Make sure that there is no continuous coolant leakage from the bleed hole while operating the engine. A small amount of coolant weeping from the bleed hole is normal. See an official Honda Service Manual or consult your Honda dealer for replacing the mechanical seal or oil seal. Both seals should be replaced at the same time.

Before & After Competition Maintenance

Between Motos & Practice Maintenance

After practice or between motos you have a chance to make additional checks and adjustments.

- Clean accumulated dirt from under the fenders and off the wheels, suspension components, handgrips, controls, and footpegs. A stiff, nylon parts cleaning brush works well.
- Check tire air pressure.
- Check spoke tension, and make sure the rim locks are secure.

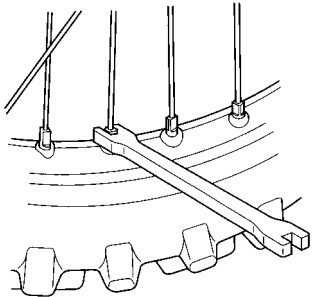

- Check to make sure the sprocket bolts and nuts are secure.
- Clean the sides of the drive chain with a stiff, nylon parts-cleaning brush. Lubricate and adjust the chain as necessary.

Do not perform maintenance while engine is running. Injury to your fingers or hands may result.

- After adjustment, check that the chain adjuster index marks (1) are in the same position on each side. This will ensure that the rear wheel is in proper alignment and allow maximum performance from the rear disc brake. Maintaining proper wheel alignment will also extend brake pad wear.

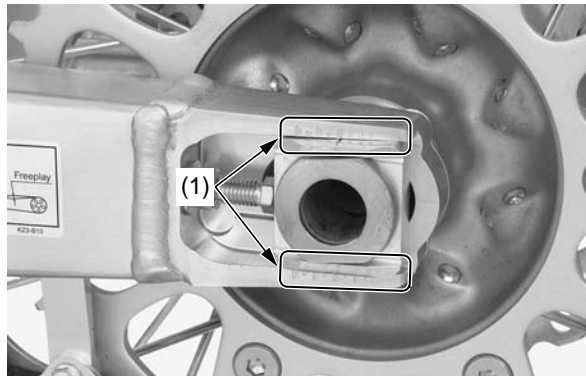

(1) chain adjuster index marks

- Suspend the front wheel above the ground and use the fork air pressure release screws (2) to release the built-up pressure (in excess of normal atmospheric pressure: 0 psi (0 kPa, 0 kgf/cm²)) in the fork tubes. This pressure is caused by normal fork action while riding. (If you are riding at altitude, remember that fork pressure of 0 at sea level will increase as elevation increases.)

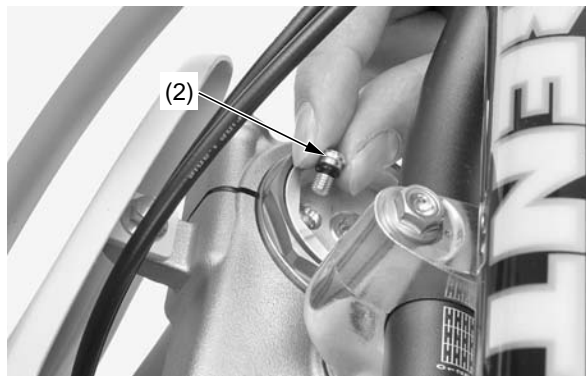

(2) fork air pressure release screws

After Competition Maintenance

It is important to the long term performance of your CRF to practice a consistent maintenance program. Right after the event is a good time to begin your next maintenance cycle.

After Race Lubrication

Apply a light coating of rust-inhibiting oil to the drive sprocket and any steel portions of the chassis or engine where the paint has worn away. This will prevent rusting of the exposed metal. Apply rust-inhibiting oil more heavily if the event was particularly wet or muddy. Take care to avoid spraying any oil near the brake pads or the brake discs.

Take care to prevent catching your fingers between the chain and sprocket.

Remove the drive chain, clean and lubricate it (pages 95, 96). Be sure the chain is wiped clean and is dry before lubricating the chain.

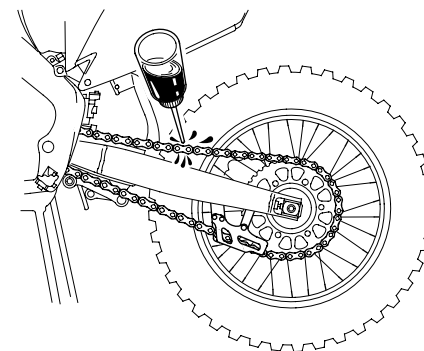

Routine Cleaning

If your CRF is only slightly dirty, it is best to clean it by hand with the aid of a stiff bristled nylon brush and some clean rags.

Take care to prevent catching your fingers between the chain and sprocket.

A variety of reasonably priced cleaning brushes are available from variety, drug, food, and hardware stores. Some of these brushes are extremely useful in removing dirt from the many tight contours of the metal pieces of your CRF. Avoid using stiff, abrasive brushes on the plastic or rubber parts.

If your CRF was exposed to sea air or salt water, rinse it as soon as possible after the event, dry it, and apply a spray lubricant to all metal parts.

If you decide to wash your CRF or use cleaners, refer to *Appearance Care* (page 105).

Maintenance Component Locations

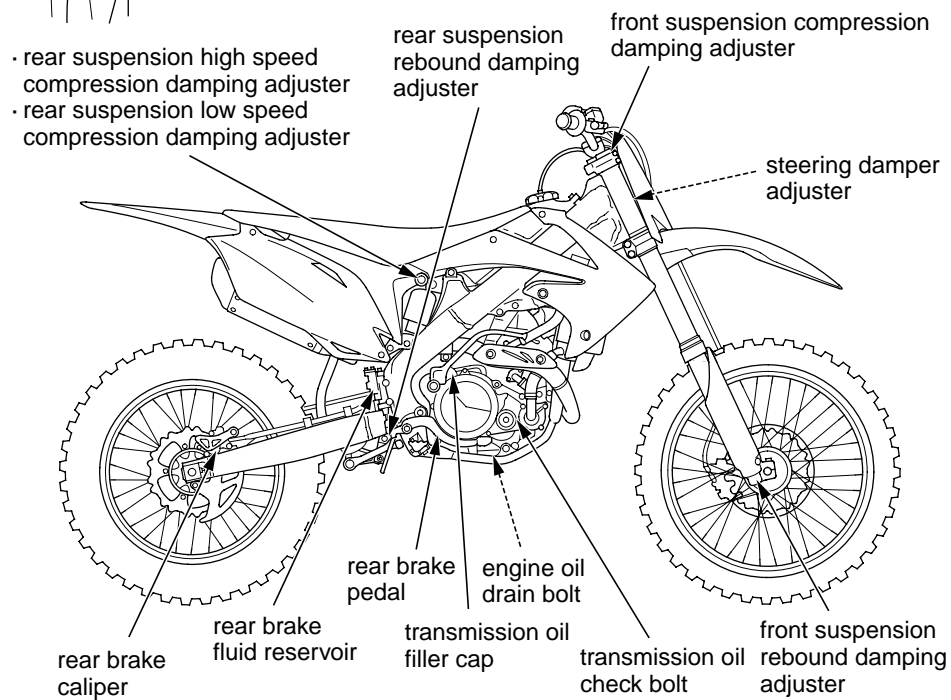
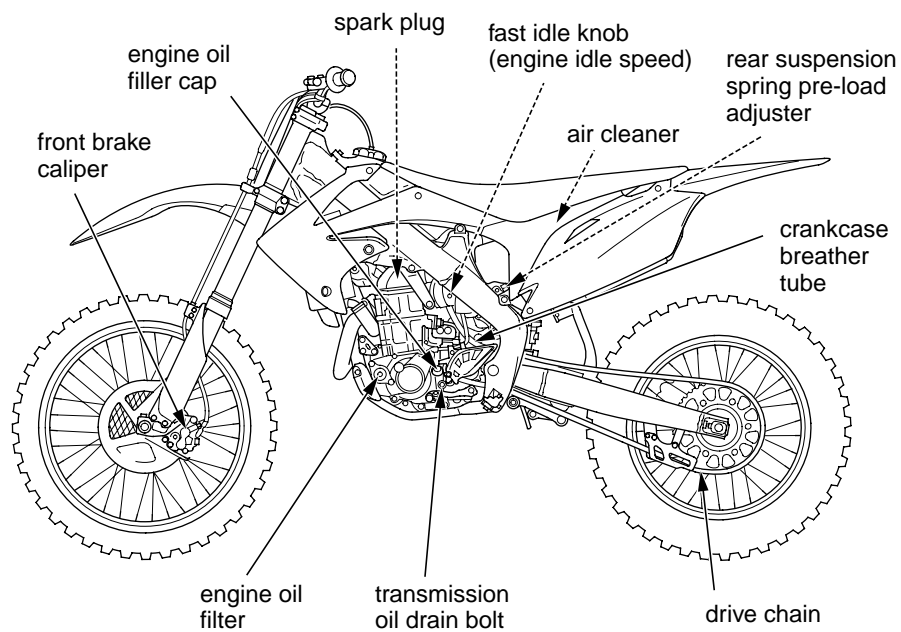
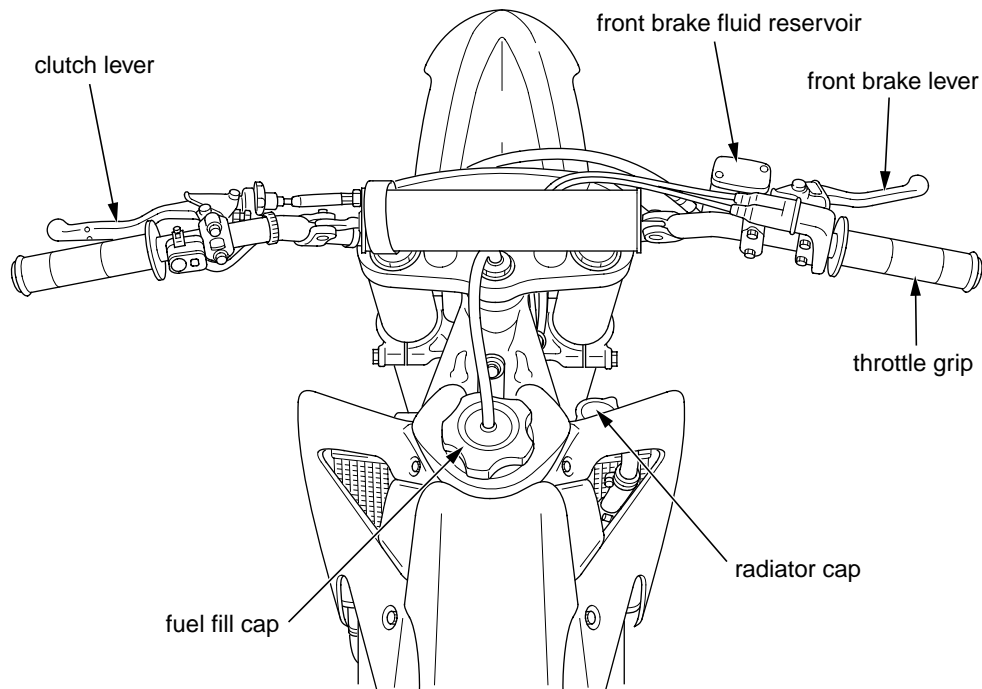

Refer to *Safety Precautions* on page 23.

Removal

1. Remove the seat mounting bolts (1).
2. Remove the seat (2) by sliding it backward.

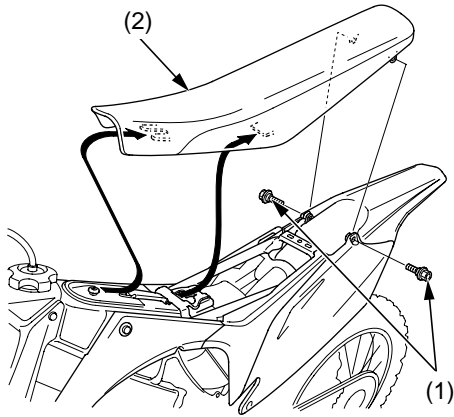

(1) seat mounting bolts (2) seat

Installation

1. Install the seat while aligning the seat front prong (1) with the seat bracket (2) and seat rear prong (3) with the ECM bracket (4).
2. Install and tighten the seat mounting bolts to the specified torque:
19 lbf·ft (26 N·m, 2.7 kgf·m)

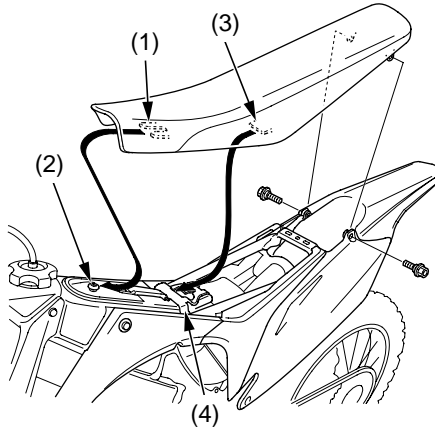

(1) seat front prong
(2) seat bracket
(3) seat rear prong
(4) ECM bracket

Fuel Tank

Refer to *Safety Precautions* on page 23.

Removal

1. Remove the shroud A bolts and collars (1).
2. Remove the shroud B bolts (2) and shrouds (3).

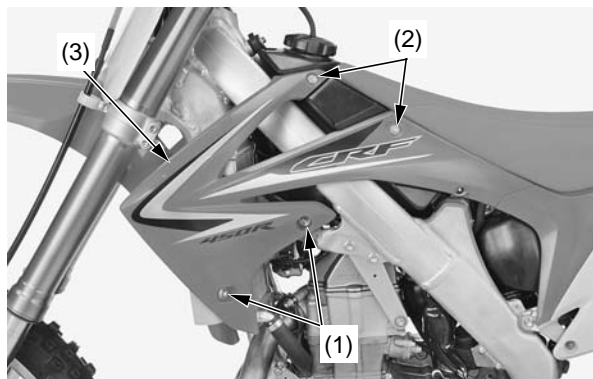

(1) shroud A bolts and collars (3) shrouds
(2) shroud B bolts

3. Remove the seat (page 33).
4. Install a hose clamp (4) to the breather tube (5) and shut the hose clamp securely.

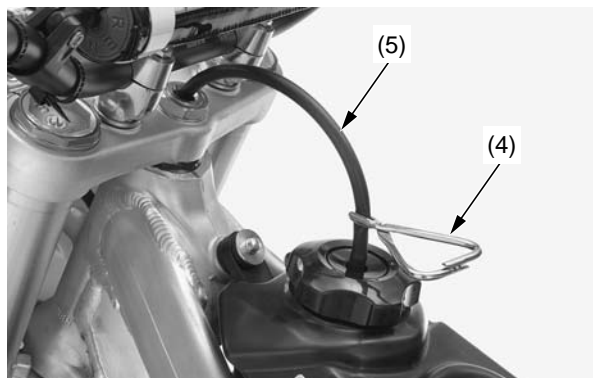

(4) hose clamp (5) breather tube

5. Pull the breather tube (5) out of steering stem nut.
6. Unhook the fuel tank band (6).

7. Remove the fuel tank bolt and collar (7).

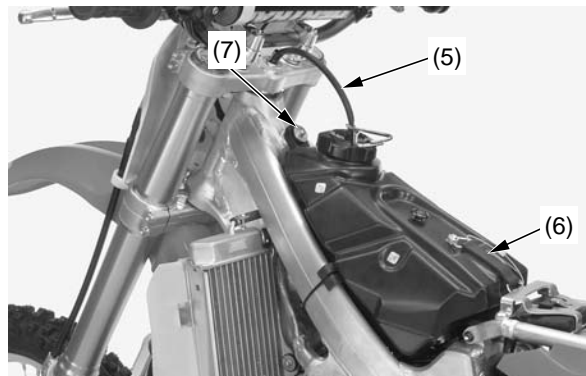

(5) breather tube
(6) fuel tank band
(7) fuel tank bolt and collar

8. Unhook the fuel feed hose (8) from the clamp (9).



(8) fuel feed hose (9) clamp

9. Pull the fuel tank (10) out of the frame and hang it to the left of the frame.
Check the fuel tank stopper cable (11) for deterioration, kinks or other damaged.
Do not support the fuel tank by the fuel feed hose (8).

⚠ WARNING

Gasoline is highly flammable and explosive. You can be burned or seriously injured when handling fuel.

- Stop the engine and keep heat, sparks and flame away.
- Handle fuel only outdoors.
- Wipe up spills immediately.

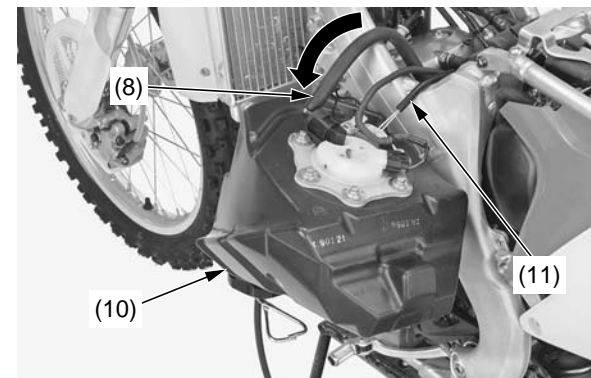

(8) fuel feed hose (11) fuel tank stopper cable
(10) fuel tank

10. Check for interference between the frame and tank and adjust the cushion rubbers (12) if necessary.

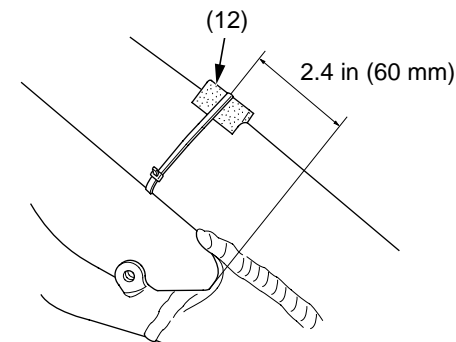

(12) cushion rubbers

Installation

1. Install the fuel feed hose (1) to the clamp (2) if it is removed.



(1) fuel feed hose (2) clamp

2. Install the fuel tank (3) on the frame.
3. Install the collar and fuel tank bolt (4).
4. Hook the fuel tank band (5).

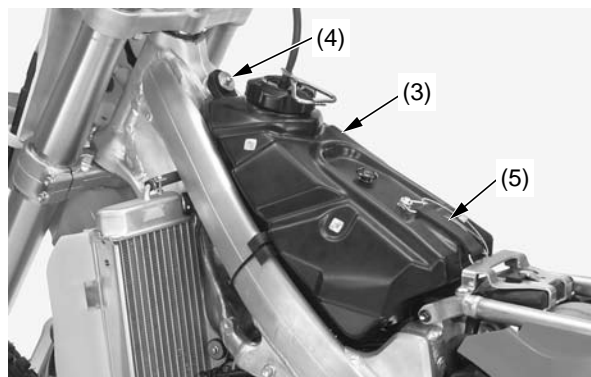

(3) fuel tank (4) collar and fuel tank bolt
(5) fuel tank band

5. Put the breather tube (6) in the steering stem nut (7).
6. Remove the hose clamp (8) from the breather tube.

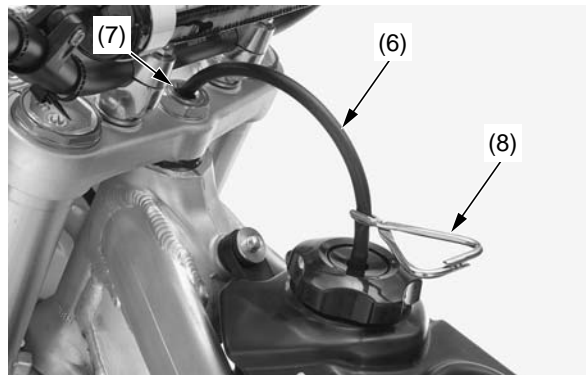

(6) breather tube (7) steering stem nut
(8) hose clamp

7. Install the shrouds (9) by aligning shroud tabs (10) with the air cleaner housing cover tabs (11).

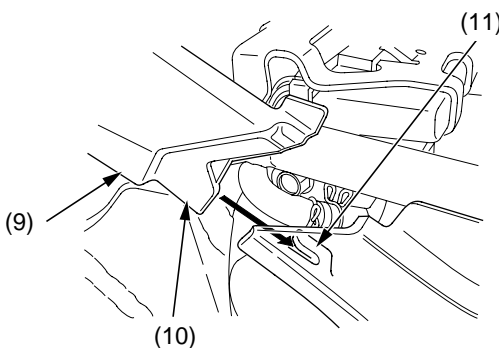

(9) shrouds (10) shroud tabs
(11) air cleaner housing cover tabs

8. Install the seat (page 33).
9. Install the shroud B bolts (12), collars and shroud A bolts (13).
Tighten the shroud B bolts to the specified torque:
3.7 lbf·ft (5 N·m, 0.5 kgf·m)

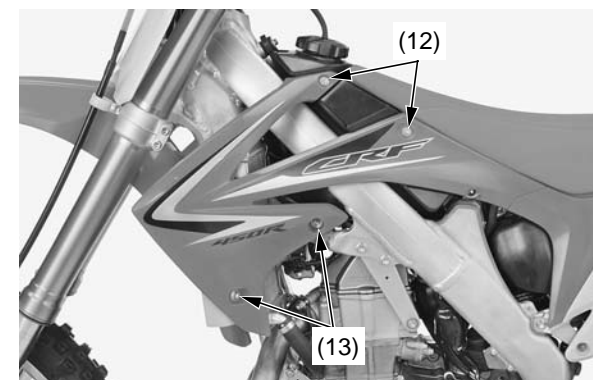

(12) shroud B bolts
(13) collars and shroud A bolts

Subframe

Refer to *Safety Precautions* on page 23.

Removal

1. Remove the side covers (1) by removing the seat mounting bolts (2) and bolts (3).
2. Remove the seat (4).

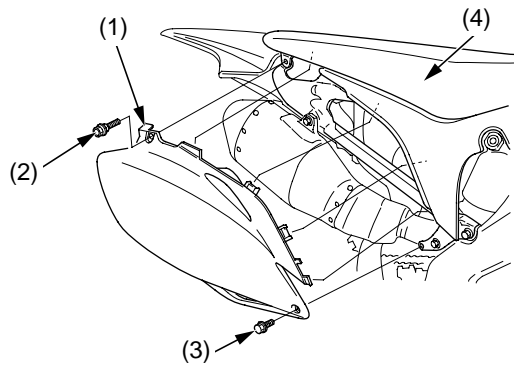

- (1) side cover (3) bolts
(2) seat mounting bolts (4) seat

3. Loosen the muffler clamp bolt (5).

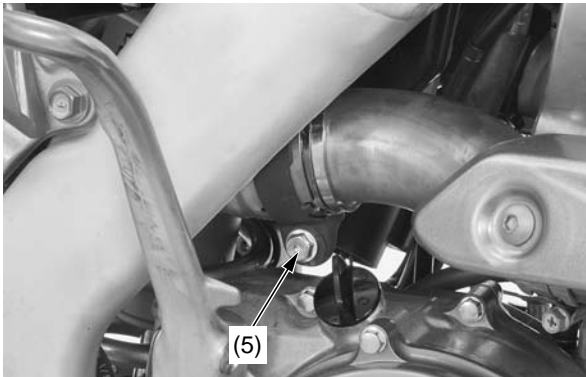

(5) muffler clamp bolt

4. Remove the muffler mounting A bolt (6), muffler mounting B bolt (7), washers (8) and muffler (9).

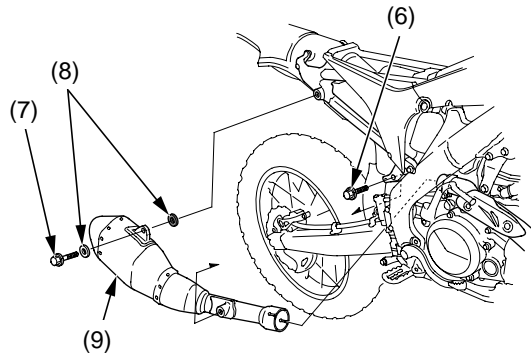

- (6) muffler mounting A bolt (8) washers
(7) muffler mounting B bolt (9) muffler

5. Disconnect the IAT sensor connector (10).

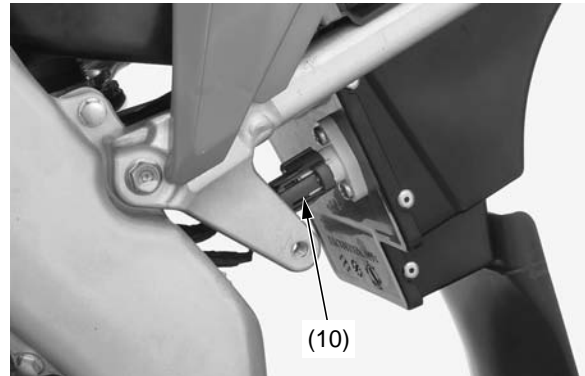

(10) IAT sensor connector

6. Remove the ECM mounting rubber (11) from the ECM bracket (12).
Unhook the fuel tank band (13).

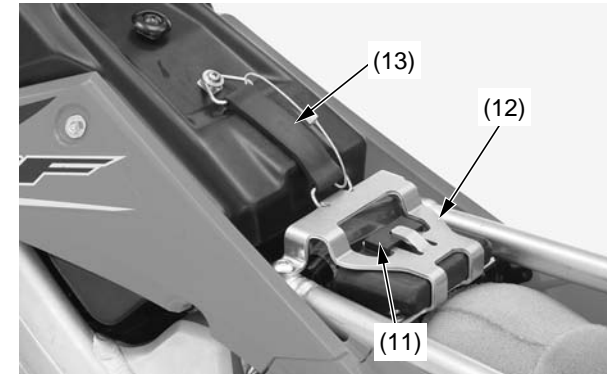

- (11) ECM mounting rubber
(12) ECM bracket
(13) fuel tank band

7. Loosen the socket bolt (14) on the air cleaner connecting tube clamp (15).

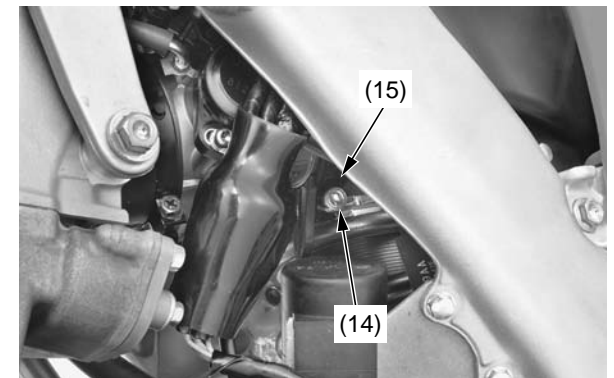

- (14) socket bolt
(15) air cleaner connecting tube clamp

- Remove the right subframe lower bolt (16) and left subframe lower bolt (17).
Remove the subframe upper bolts (18).

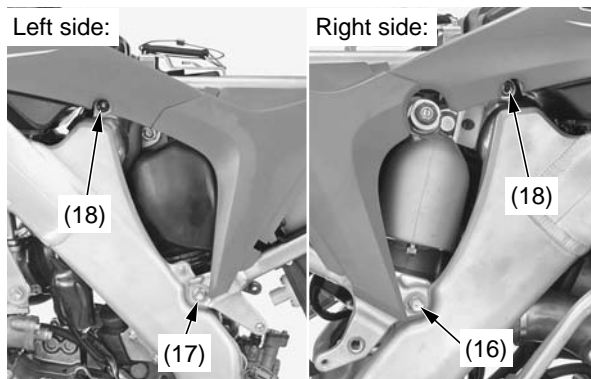

(16) right subframe lower bolt
(17) left subframe lower bolt
(18) subframe upper bolts

- Slightly pull the subframe (19) backward and disconnect the crankcase breather tube (20) from the air cleaner connecting tube. Remove the subframe.

Be careful not to damage the ECM and wires.

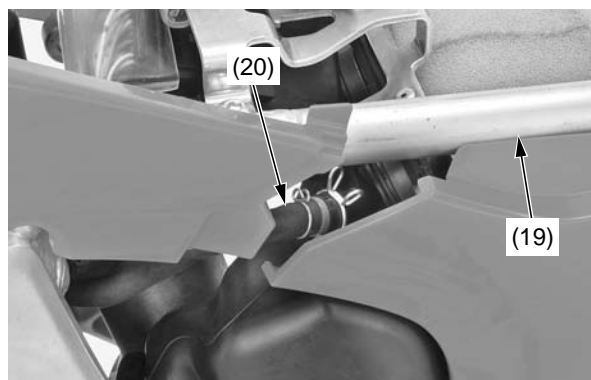

(19) subframe
(20) crankcase breather tube

Installation

- Connect the crankcase breather tube (1).

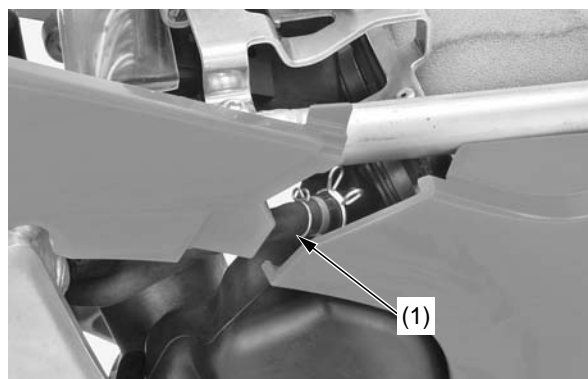

(1) crankcase breather tube

- Position the ECM (2) in the bracket (3).
- Align the shroud tabs (4) with the air cleaner housing cover tabs (5).
- Loosely attach the upper and lower end of the subframe to the main frame while connecting the air cleaner connecting tube (6) to the throttle body (7).
- Loosely install all subframe bolts.

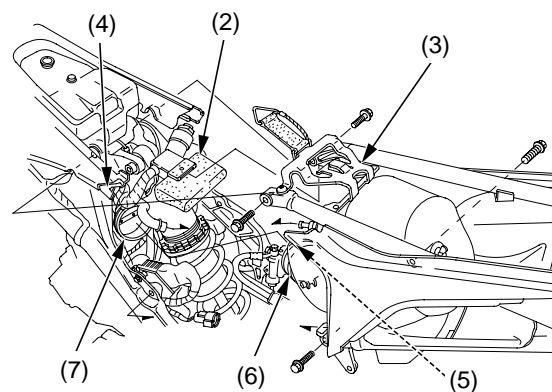

(2) ECM
(3) bracket
(4) shroud tabs
(5) air cleaner housing cover tabs
(6) air cleaner connecting tube
(7) throttle body

- Align the subframe with the rear wheel and tighten the subframe upper bolts (8), left subframe lower bolt (9) and right subframe lower bolt (10) to the specified torque:
subframe upper bolts:
24 lbf·ft (33 N·m, 3.4 kgf·m)
left subframe lower bolt:
24 lbf·ft (33 N·m, 3.4 kgf·m)
right subframe lower bolt:
36 lbf·ft (49 N·m, 5.0 kgf·m)

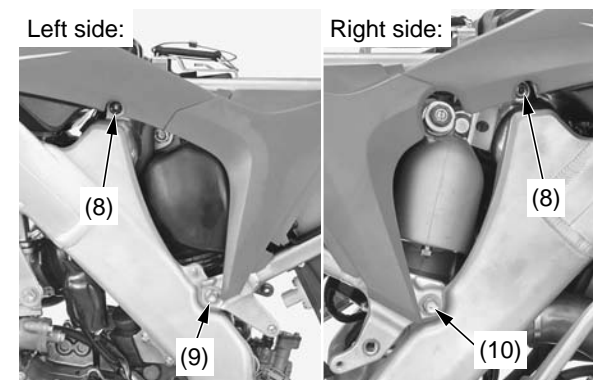

(8) subframe upper bolts
(9) left subframe lower bolt
(10) right subframe lower bolt

(cont'd)

Subframe

7. Make sure the air cleaner connecting tube tab (11) aligns with the air cleaner connecting tube clamp hole (12).

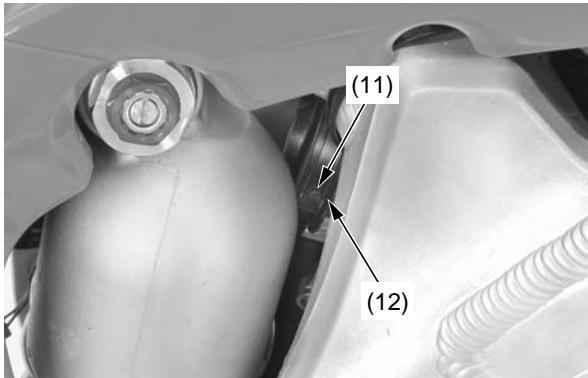

(11) air cleaner connecting tube tab
(12) air cleaner connecting tube clamp hole

8. Tighten the socket bolt (13) on the air cleaner connecting tube clamp to the specified torque:
0.5 lbf-ft (0.7 N-m, 0.1 kgf-m)
 Check the distance between the band ends is 0.18 ± 0.06 in (4.5 ± 1.5 mm).

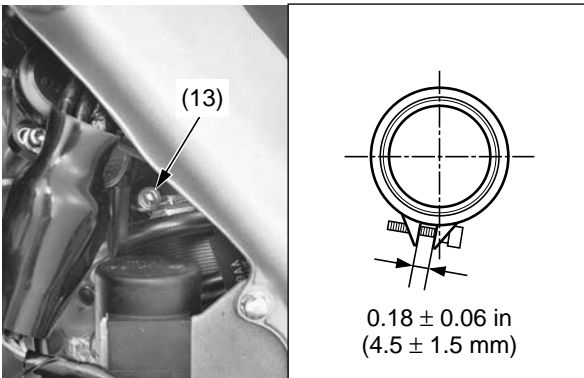

(13) socket bolt

9. Hook the fuel tank band (14).
 Install the ECM mounting rubber (15) to the ECM bracket (16).

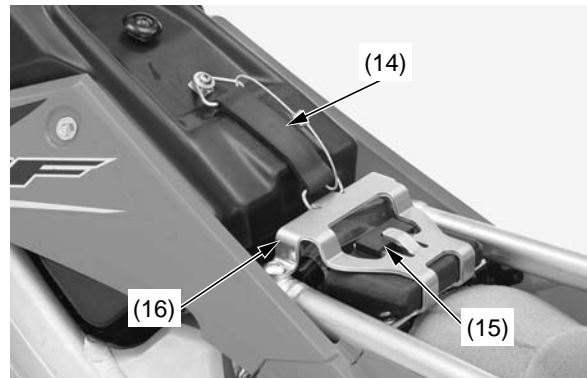

(14) fuel tank band
(15) ECM mounting rubber
(16) ECM bracket

10. Connect the IAT sensor connector (17).

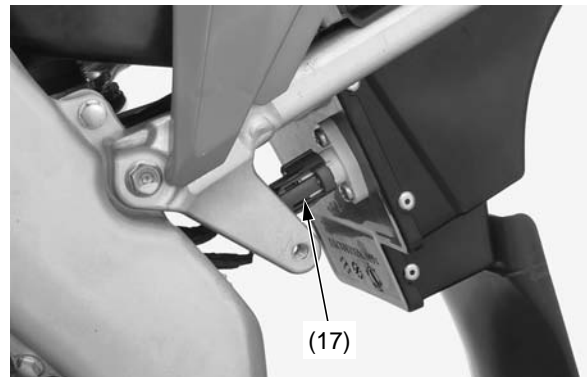

(17) IAT sensor connector

11. Remove the old gasket from exhaust pipe.
 12. Install the muffler clamp (18) and a new gasket (19) to the exhaust pipe (20).

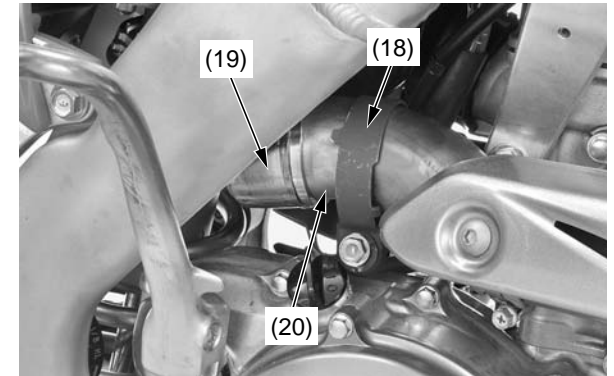

(18) muffler clamp
(19) gasket (new)
(20) exhaust pipe

13. Install the muffler (21).
 14. Install the muffler clamp (18) by aligning the tab (22) of the muffler clamp with the cutout (23) of the muffler.

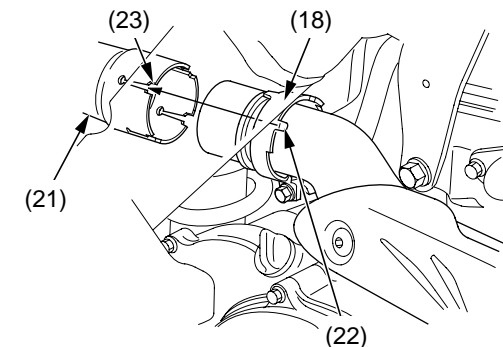

(18) muffler clamp
(21) muffler
(22) tab
(23) cutout

15. Install the washers (24), muffler mounting B bolt (25) and muffler mounting A bolt (26).

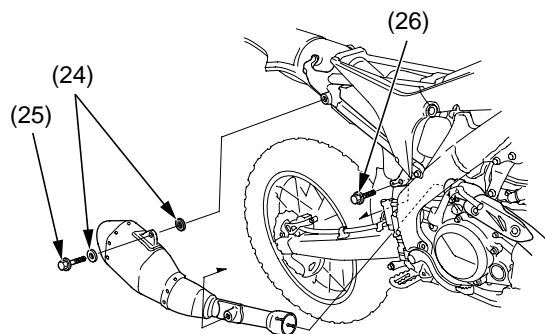

- (24) washers
- (25) muffler mounting B bolt
- (26) muffler mounting A bolt

16. Tighten the muffler clamp bolt (27) to the specified torque:
15 lbf-ft (21 N·m, 2.1 kgf·m)

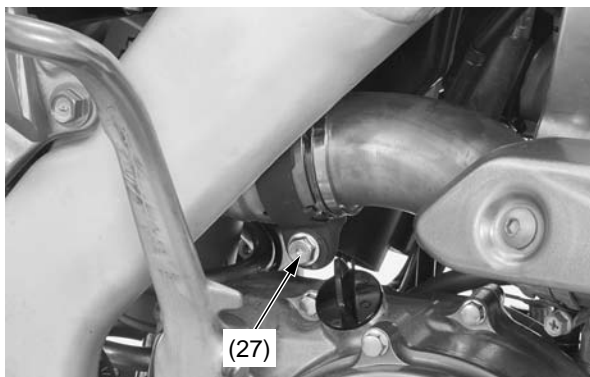

- (27) muffler clamp bolt

17. Tighten the muffler mounting B bolt (25) and muffler mounting A bolt (26) to the specified torque:

19 lbf-ft (26 N·m, 2.7 kgf·m)

18. Install the seat (28).

19. Install the side covers (29), seat mounting bolts (30) and bolts (31). Then tighten the seat mounting bolts and side cover bolts to the specified torque:

seat mounting bolts:

19 lbf-ft (26 N·m, 2.7 kgf·m)

side cover bolts:

7 lbf-ft (10 N·m, 1.0 kgf·m)

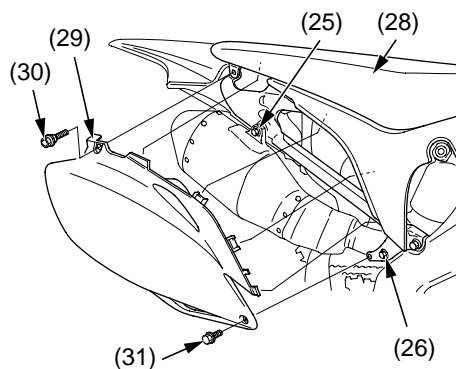

- (25) muffler mounting B bolt
- (26) muffler mounting A bolt
- (28) seat
- (29) side covers
- (30) seat mounting bolts
- (31) bolts

Fuel System

Refer to *Safety Precautions* on page 23.

Fuel

Type	Unleaded
Pump Octane Number	91 (or higher)

Use only unleaded fuel in your CRF. If you ride your CRF in a country where leaded fuel might be available, take precautions to use only unleaded fuel.

Your engine is designed to use any unleaded gasoline that has a pump octane number of 91 or higher. Gasoline pumps at service stations normally display the pump octane number. For information on the use of oxygenated fuels, see page 149.

Use of lower octane gasoline can cause persistent “pinging” or “spark knock” (a louder rapping noise) which, if severe, can lead to engine damage. (Light pinging experienced while operating under a heavy load, such as climbing a hill, is no cause for concern.)

If pinging or spark knock occurs at a steady engine speed under normal load, change brands of gasoline. If pinging or spark knock persists, consult your Honda dealer.

Never use stale or contaminated gasoline. Avoid getting dirt, dust or water in the fuel tank.

Refueling Procedure

1. To open the fuel fill cap (1), pull the breather tube (2) out of the steering stem nut (3). Turn the fuel fill cap counterclockwise and remove it.

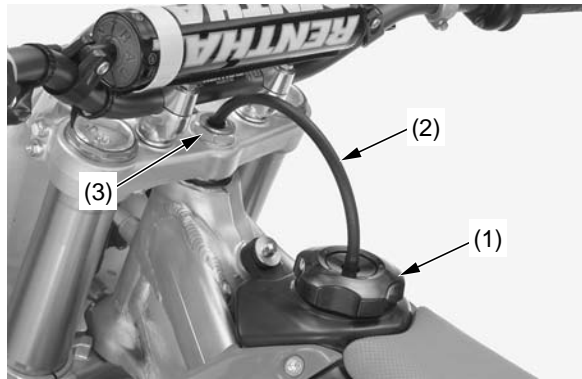

(1) fuel fill cap (3) steering stem nut
(2) breather tube

2. Add fuel until the level reaches the bottom of the filler neck.

Fuel Tank Capacity: 1.5 US gal (5.7 ℓ)
Be careful not to damage the fuel pump while filling the fuel tank.
Avoid overfilling the tank. There should be no fuel in the filler neck.

⚠ WARNING

Gasoline is highly flammable and explosive. You can be burned or seriously injured when handling fuel.

- Stop the engine and keep heat, sparks and flame away.
- Handle fuel only outdoors.
- Wipe up spills immediately.

3. Close the fuel fill cap and insert the breather tube in the steering stem nut.

Fuel Line

1. Hang the fuel tank to the left side of the frame (page 34).
2. Remove the fuel quick connect fitting cover (1).
3. Check the fuel line (2) for cracks, deterioration, damage or leakage. Replace the fuel line, if necessary.
4. Install the fuel quick connect fitting cover.
5. Install the fuel tank (page 34).

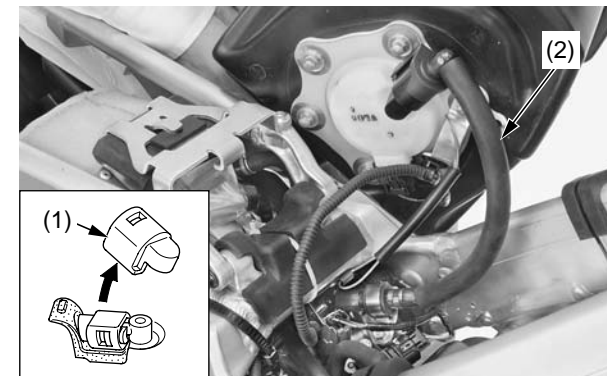

(1) fuel quick connect fitting cover
(2) fuel line

Fuel Pressure Relieving

1. Hang the fuel tank to the left side of the frame (page 34).
2. Disconnect the fuel pump connector (1).

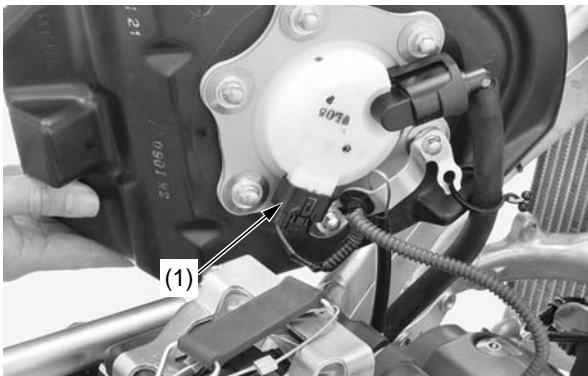

(1) fuel pump connector

3. Reposition the fuel tank and start the engine and let it idle until the engine stalls.

Fuel Line Replacement

Disconnection

1. Relieve the fuel pressure (page 41).
2. Hang the fuel tank to the left side of the frame.
3. Remove the fuel quick connect fitting cover (1) from the fuel pump (2).
4. Check the fuel quick connect fitting (3) for dirt, and clean if necessary.

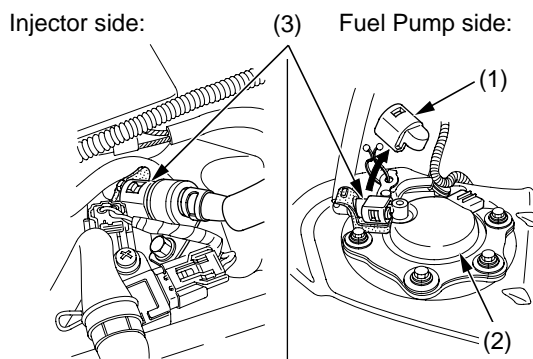

- (1) fuel quick connect fitting cover
- (2) fuel pump
- (3) fuel quick connect fitting

5. Remove the bolt (4), clamp and setting rubber (5).

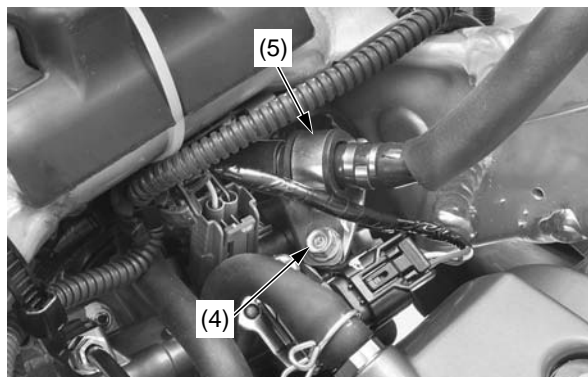

(4) bolt

(5) clamp and setting rubber

6. Pull and release the joint rubber (6) of the injector side from the retainer (7).

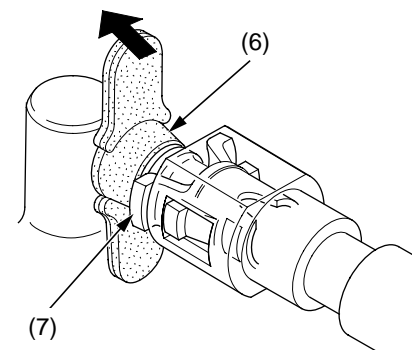

- (6) joint rubber (injector side only)
- (7) retainer

7. Place a shop towel (8) over the fuel quick connect fitting.

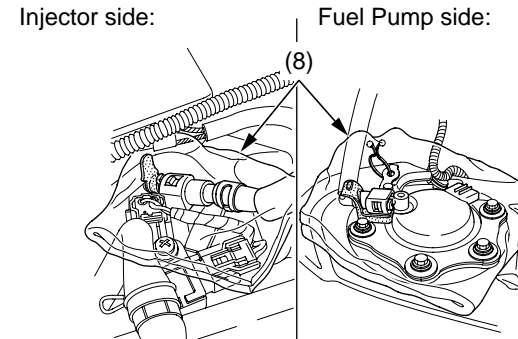

(8) shop towel

(cont'd)

Fuel System

8. Hold the connector with one hand and squeeze the retainer tabs (9) with the other hand to remove them from the locking pawls (10). Pull the connector off, then remove the retainer.

- Use a shop towel to absorb the remaining fuel in the fuel feed hose.
- Be careful not to damage the hose or other parts.
- Do not use tools.
- If the connector does not move, keep the retainer tabs pressed down, and alternately pull and push the connector until it comes off easily.

⚠ WARNING

Gasoline is highly flammable and explosive. You can be burned or seriously injured when handling fuel.

- Stop the engine and keep heat, sparks and flame away.
- Handle fuel only outdoors.
- Wipe up spills immediately.

Injector side:

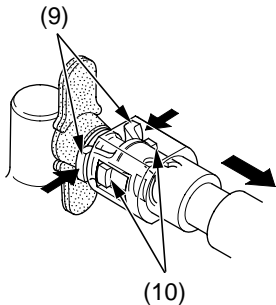

(9) retainer tabs
(10) locking pawls

Fuel Pump side:

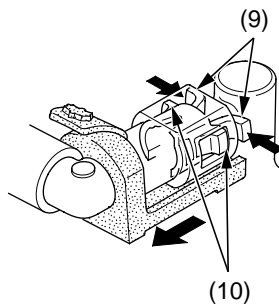

9. To prevent damage and keep foreign matter out, cover the disconnected connectors (11) and fuel joints (12) with plastic bags (13).

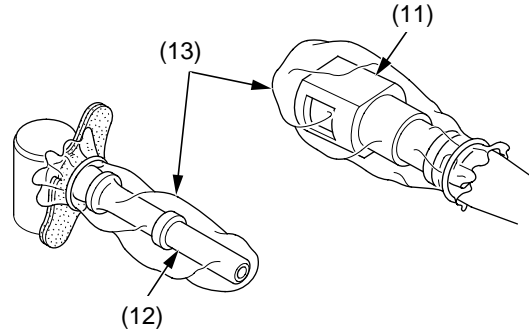

(11) disconnected connector
(12) fuel joint
(13) plastic bags

Connection

1. Insert a new retainer (1) into the connector (2) by aligning its locking pawls (3) with the connector grooves (4).

- Always replace the retainer of the quick connect fitting when the fuel feed hose is disconnected.
- If the joint rubber is damaged or cut, replace it with a new one.
- Do not bend or twist the fuel feed hose.
- If any retainer needs replacing, use the same manufacturer's retainer as the ones being removed (The various manufacturer's feature different retainer specification).

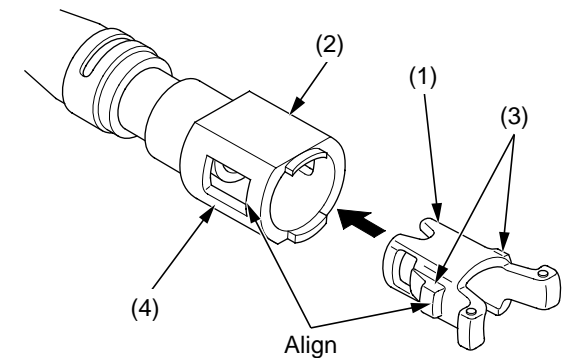

(1) retainer (new)
(2) connector

(3) locking pawls
(4) connector grooves

2. Install the joint rubber (5) and seat it onto the fuel joint as shown. Align the fuel quick connect fitting with the fuel joint. Then press the quick fitting onto the pipe of the fuel joint until both retainer pawls lock with a "click".
If it is hard to connect, put a small amount of engine oil on the pipe end.

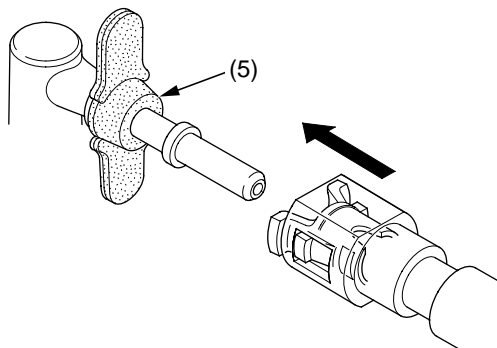

(5) joint rubber (injector side only)

3. Make sure the connection is secure and that the pawls are firmly locked into place; check visually and by pulling the connector.
4. Make sure the joint rubber (5) is in place between the flange (6) and retainer tab (7).

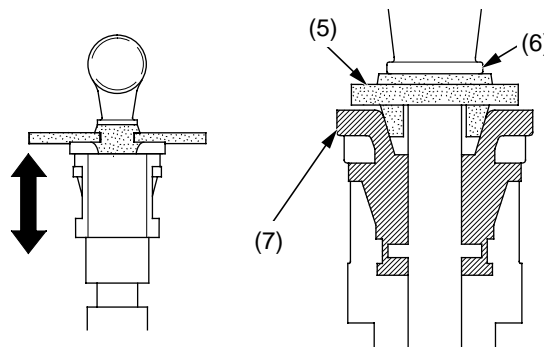

(5) joint rubber (injector side only)
(6) flange
(7) retainer tab

5. Install the rubber (8), clamp (9) and bolt (10) by aligning the clamp tab (11) with the groove (12) of the stay.

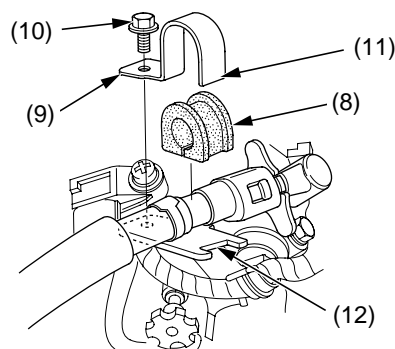

(8) rubber
(9) clamp
(10) bolt
(11) clamp tab
(12) groove

6. Install the fuel quick connect fitting cover (13) and set the rubber cover tab (14) to the hole (15) of the fuel quick connect fitting cover.

Be sure the rubber cover (16) is properly installed between the fuel quick connect fitting cover and fuel pump.

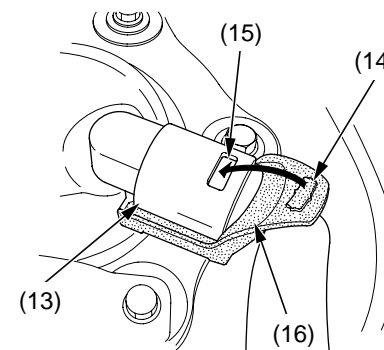

(13) fuel quick connect fitting cover
(14) rubber cover tab
(15) fuel quick connect fitting cover hole
(16) rubber cover

7. Increase the fuel pressure (page 44).

Fuel System

Fuel Pressure Increasing

Make sure the fuel remains enough (0.3 US gal (1.0 ℓ) minimum) in the fuel tank and add fuel if necessary before increasing fuel pressure.

1. Connect the fuel pump connector (1).

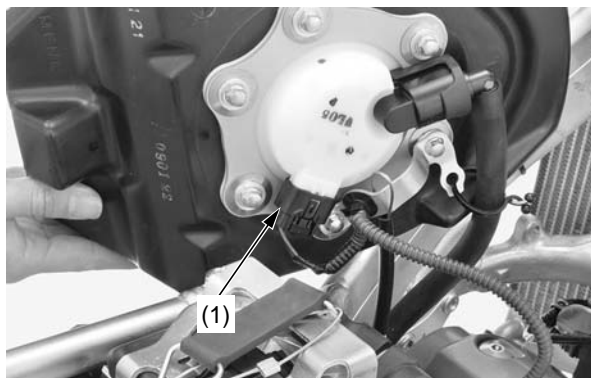

(1) fuel pump connector

2. Disconnect the DLC/fuel pump sub harness connector (2).



(2) DLC/fuel pump sub harness connector

3. Before connecting the battery harness cables to a 12V battery (3), make sure that the battery harness selector switches (4) are OFF.
4. Connect the battery harness positive (+) cable (5) first, then connect the battery harness negative (-) cable (6) to the terminals of a 12V battery .
5. Connect the battery harness adaptor (7) between the battery harness (8) and the DLC/fuel pump sub harness connector as shown.

- Battery harness 070MZ-MEN0100
- Battery harness adaptor 070MZ-KRN0100

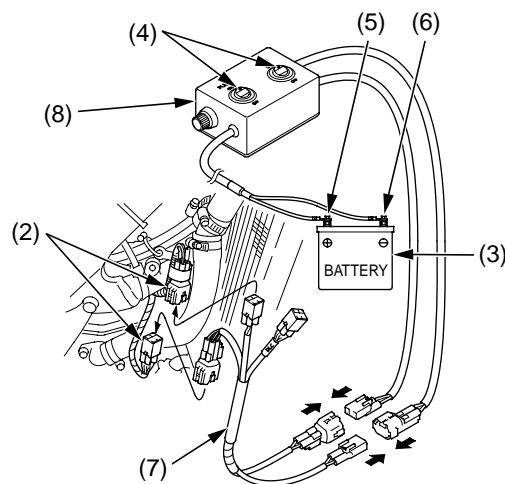

- (2) DLC/fuel pump sub harness connector
- (3) battery
- (4) battery harness selector switches
- (5) positive (+) cable
- (6) negative (-) cable
- (7) battery harness adaptor
- (8) battery harness

6. Position the fuel tank on the main frame.
7. Turn the “PUMP” selector switch (9) ON. The selector switches can be used to change power delivery as follows:
 - “ECM” selector switch ON:
Power to ECM only.
 - “PUMP” selector switch ON:
Power to fuel pump only.
 - Both selector switches ON:
Power to ECM and fuel pump.
8. Run the fuel pump for about 3 – 5 seconds, and fuel pressure will rise.
9. Turn the “PUMP” selector switch OFF. Check that there is no leakage in the fuel line.

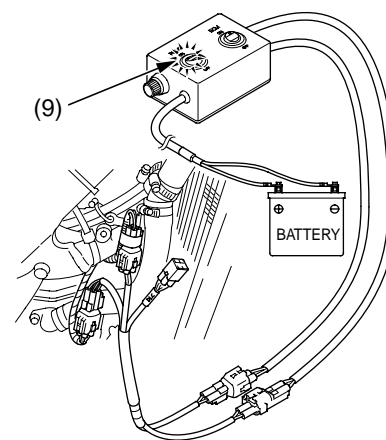

(9) “PUMP” selector switch

10. Make sure that the battery harness selector switches are OFF.
11. Disconnect the battery harness negative (-) cable from the battery first, then disconnect the battery harness positive (+) cable.
12. Remove the battery harness and battery harness adaptor.
13. Connect the DLC/fuel pump sub harness connector.
14. Install the fuel tank (page 35).

Refer to *Safety Precautions* on page 23.

Using the proper oil, and regularly checking, adding, and changing oil will help extend the service life of the engine. Even the best oil wears out. Changing oil helps get rid of dirt and deposits. Operating the engine with old or dirty oil can damage your engine. Running the engine with insufficient oil can cause serious damage to the engine.

Oil Recommendation

API classification	SG or higher except oils labeled as energy conserving on the circular API service label
viscosity (weight)	SAE 10W-30
JASO T 903 standard	MA
suggested oil*	Pro Honda GN4 4-stroke oil (USA & Canada), or Honda 4-stroke oil (Canada only), or an equivalent motorcycle oil*

* Suggested 4-stroke engine oils are equal performance to SJ oils that are not labeled as energy conserving on the circular API service label.

- Your CRF does not need oil additives. Use the recommended oil.
- Do not use API SH or higher 4-stroke engine oils displaying a circular API “energy conserving” service label on the container. They may affect lubrication.



NOT RECOMMENDED



OK

Other viscosities shown in the following chart may be used when the average temperature in your riding area is within the indicated range.

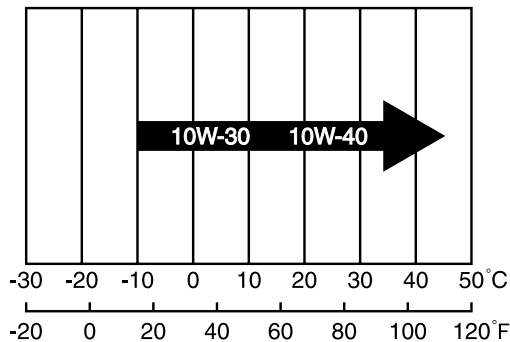

JASO T 903 standard

The JASO T 903 standard is an index for engine oils for 4-stroke motorcycle engines. There are two classes: MA and MB. Oil conforming to the standard is labeled on the oil container. For example, the following label shows the MA classification.

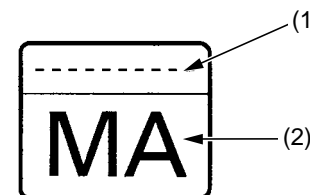

PRODUCT MEETING JASO T 903
COMPANY GUARANTEEING THIS MA PERFORMANCE:

- (1) code number of the sales company of the oil
(2) oil classification

Engine Oil

Checking & Adding Oil

1. Run the engine at idle for 3 minutes, then shut it off.
2. Wait 3 minutes after shutting off the engine to allow the oil to properly distribute itself in the engine.
3. Support the CRF in an upright position on a level surface.
4. Remove the engine oil filler cap/dipstick (1), wipe it clean, and insert the engine oil filler cap/dipstick without screwing it in. Remove the oil filler cap/dipstick.
5. Check that the oil level is between the upper (2) and lower (3) level marks on the engine oil filler cap/dipstick.
 - If the oil is at or near the upper level mark, you do not have to add oil.
 - If the oil is below or near the lower level mark, add the recommended oil until it reaches the upper level mark. (Do not overfill)Reinstall the engine oil filler cap/dipstick. Repeat steps 1–5.

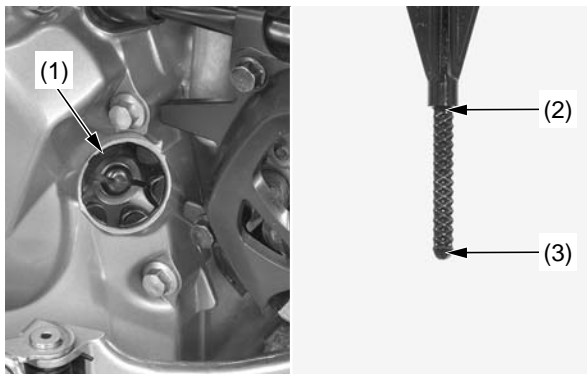

- (1) engine oil filler cap/dipstick
(2) upper level mark
(3) lower level mark

6. Check that the O-ring (4) is in good condition and replace it if necessary.
7. Reinsert the engine oil filler cap/dipstick (1).

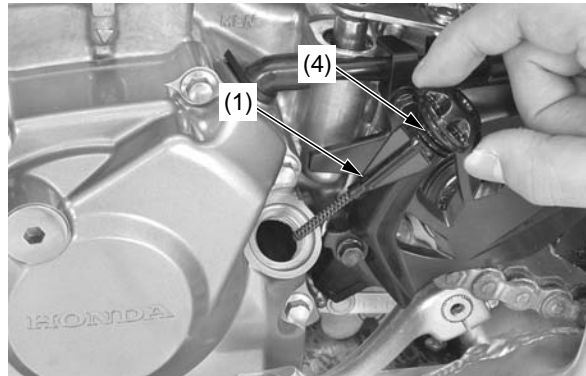

- (1) engine oil filler cap/dipstick
(4) O-ring

8. Check for oil leaks.

Changing Engine Oil & Filter

1. Run the engine at idle for 3 minutes, then shut it off.
 2. Support the CRF in an upright position on a level surface.
 3. Remove the engine oil filler cap/dipstick (1) from the left crankcase cover.
 4. Place an oil drain pan under the engine to catch the oil. Then remove the engine oil drain bolt (2) and sealing washer (3).
 5. With the engine stop button pushed, repeat kickstarter operation approximately five times to drain the engine oil completely.
 6. After the oil has drained, apply engine oil to the drain bolt threads and tighten it with a new sealing washer to the specified torque: 12 lbf·ft (16 N·m, 1.6 kgf·m)
- Pour the drained oil into a suitable container and dispose of it in an approved manner (page 140).

NOTICE

Improper disposal of drained fluids is harmful to the environment.

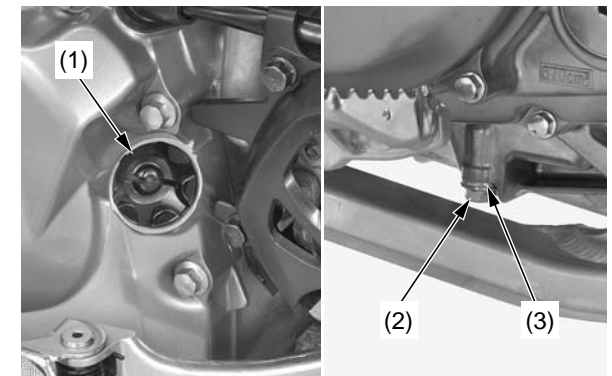

- (1) engine oil filler cap/dipstick
(2) engine oil drain bolt
(3) sealing washer (new)

7. It is recommended to replace the oil and filter every 6 races or about every 15.0 hours. However, if you replace only the oil before the recommended interval, see page 25.
8. Remove the left engine guard bolt/washer (4), collar (5) and left engine guard (6).

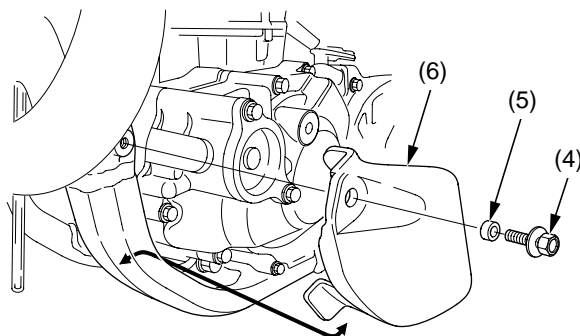

- (4) left engine guard bolt/washer
- (5) collar
- (6) left engine guard

9. Remove the oil filter cover bolts (7) and oil filter cover (8).
10. Remove the oil filter (9) and O-ring (10) from the oil filter cover.

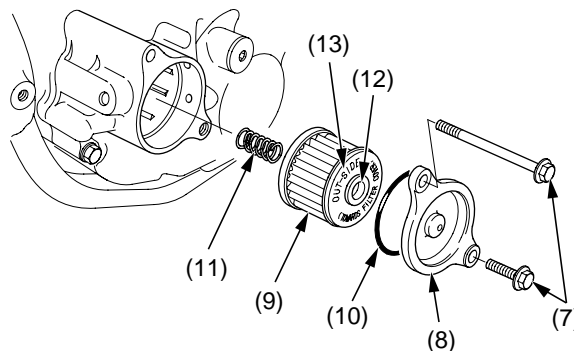

- (7) oil filter cover bolts
- (8) oil filter cover
- (9) oil filter
- (10) O-ring
- (11) spring
- (12) rubber seal
- (13) "OUT-SIDE" mark

NOTICE

Using the wrong oil filter may result in leaks or engine damage.

11. Apply grease to the filter side of the spring end, then install the spring (11) into the new oil filter.
12. Position the spring against the engine crankcase and install a new oil filter with the rubber seal (12) facing out, away from the engine. You should see the "OUT-SIDE" mark (13) on the filter body, near the seal. Use a new Honda Genuine oil filter or a filter of equal quality specified for your model.

NOTICE

If the oil filter is not installed properly, it will cause serious engine damage.

13. Apply engine oil to a new O-ring and install it to the oil filter cover.
14. Install the oil filter cover being careful not to damage the O-ring, then tighten the oil filter cover bolts to the specified torque:
9 lbf-ft (12 N-m, 1.2 kgf-m)
15. Install the left engine guard and collar, then tighten the left engine guard bolt to the specified torque:
7 lbf-ft (10 N-m, 1.0 kgf-m)
16. Fill the crankcase with the recommended oil.
Capacity: 0.66 US qt (0.62 l)
after draining and filter change
0.61 US qt (0.58 l)
after draining
17. Install the engine oil filler cap/dipstick.
18. Check the engine oil level by following the steps in *Checking & Adding Oil* (page 46).
Pour the drained oil into a suitable container and dispose of it in an approved manner (page 140).

NOTICE

Improper disposal of drained fluids is harmful to the environment.

Transmission Oil

Refer to *Safety Precautions* on page 23.

Using the proper oil, and regularly checking, adding, and changing oil will help extend the service life of the transmission and clutch. Even the best oil wears out. Changing oil helps get rid of dirt and deposits. Operating the engine with old or dirty oil can damage your engine. Running the engine with insufficient oil can cause serious damage to the clutch and transmission.

Oil Recommendation

API classification (4-stroke engine oil only)	SG or higher except oils labeled as energy conserving on the circular API service label
viscosity (weight)	SAE 10W-30
JASO T903 standard	MA
others	without friction modifiers as molybdenum additives
suggested oil*	Pro Honda GN4 4-stroke oil (USA & Canada), or Honda 4-stroke oil (Canada only), or an equivalent motorcycle oil*

* Suggested 4-stroke engine oils are equal performance to SJ oils that are not labeled as energy conserving on the circular API service label.

- Your CRF does not need oil additives. Use the recommended oil.
- Do not use oils with graphite or molybdenum additives. They may adversely affect clutch operation.
- Do not use API SH or higher 4-stroke engine oils displaying a circular API “energy conserving” service label on the container. They may affect lubrication and clutch performance.



NOT RECOMMENDED



OK

Other viscosities shown in the following chart may be used when the average temperature in your riding area is within the indicated range.

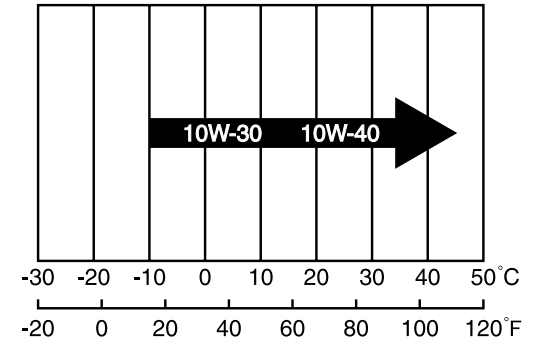

JASO T 903 standard

The JASO T 903 standard is an index for engine oils for 4-stroke motorcycle engines. There are two classes: MA and MB. Oil conforming to the standard is labeled on the oil container. For example, the following label shows the MA classification.

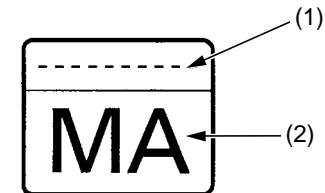

PRODUCT MEETING JASO T 903
COMPANY GUARANTEEING THIS MA PERFORMANCE:

- (1) code number of the sales company of the oil
(2) oil classification

Checking & Adding Oil

1. Run the engine at idle for 3 minutes, then shut it off.
2. Wait 3 minutes after shutting off the engine to allow the oil to properly distribute itself in the clutch and transmission.
3. Support the CRF in an upright position on a level surface.
4. Remove the transmission oil filler cap (1), oil check bolt (2) and sealing washer (3) from the right crankcase cover. A small amount of oil should flow out of the oil check bolt hole. Allow any excess oil to flow out of the oil check bolt hole.

If no oil flows out of the oil check bolt hole, add oil slowly through the transmission oil filler hole until oil starts to flow out of the oil check bolt hole.

Install the oil check bolt with the sealing washer and transmission oil filler cap. Repeat steps 1 – 4.

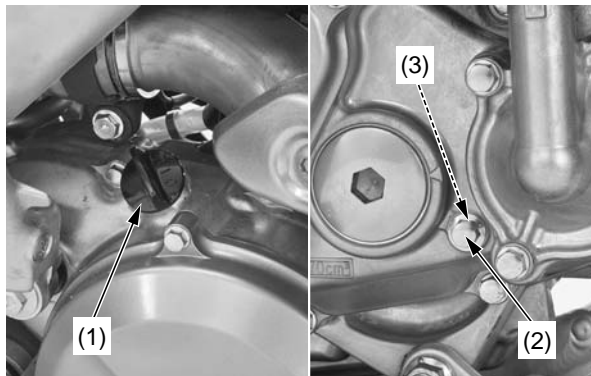

(1) transmission oil filler cap (2) oil check bolt (3) sealing washer (new)

5. After inspecting the oil level or adding oil, tighten the oil check bolt with a new sealing washer to the specified torque:
9 lbf-ft (12 N·m, 1.2 kgf·m)

6. Check that the O-ring (4) is in good condition and replace it if necessary.
7. Reinstall the transmission oil filler cap (1).
8. Check for oil leaks.

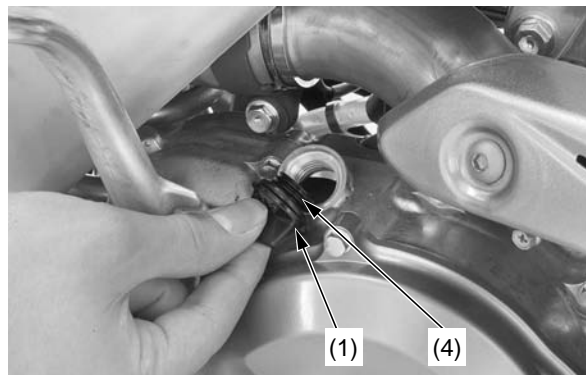

(1) transmission oil filler cap
(4) O-ring

Replacing Transmission Oil

1. Run the engine at idle for 3 minutes, then shut it off.
2. Support the CRF in an upright position on a level surface.
3. Remove the transmission oil filler cap (1) from the right crankcase cover.
4. Place an oil drain pan under the engine to catch the oil. Then remove the transmission oil drain bolt (2) and sealing washer (3).
5. After the oil has drained, apply engine oil to the drain bolt threads and tighten it with a new sealing washer to the specified torque:
12 lbf-ft (16 N·m, 1.6 kgf·m)

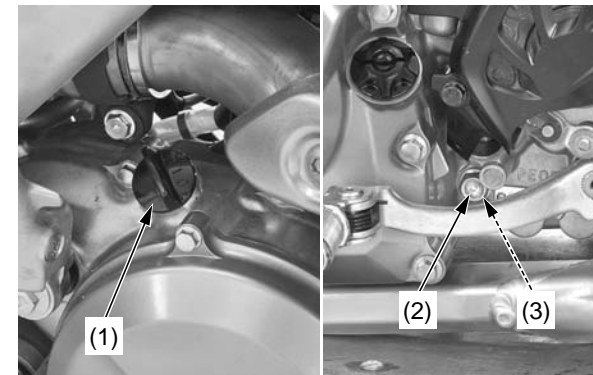

(1) transmission oil filler cap
(2) transmission oil drain bolt
(3) sealing washer (new)

6. Fill the crankcase with recommended oil.
Capacity: 0.62 US qt (0.59 ℓ) after draining.
7. Check the transmission oil level by following the steps in *Checking & Adding Oil* (this page).

Pour the drained oil into a suitable container and dispose of it in an approved manner (page 140).

NOTICE

Improper disposal of drained fluids is harmful to the environment.

Coolant

Your CRF's liquid cooling system dissipates engine heat through the coolant jacket that surrounds the cylinder and cylinder head.

Maintaining the coolant will allow the cooling system to work properly and prevent freezing, overheating, and corrosion.

Coolant Recommendation

Use Pro Honda HP Coolant or an equivalent high quality ethylene glycol antifreeze containing corrosion protection inhibitors specifically recommended for use in aluminum engines. Check the antifreeze container label.

Use only distilled water as a part of the coolant solution. Water that is high in mineral content or salt may be harmful to the aluminum engine.

NOTICE

Using coolant with silicate inhibitors may cause premature wear of the mechanical seal or blockage of the radiator passages. Using tap water may cause engine damage.

The factory provides a 50/50 solution of antifreeze and water in this motorcycle. This coolant solution is recommended for most operating temperatures and provides good corrosion protection.

Decreasing the concentration of antifreeze to less than 40% will not provide proper corrosion protection.

Increasing the concentration of antifreeze is not recommended because it decreases cooling system performance. Higher concentrations of antifreeze (up to 60%) should only be used to provide additional protection against freezing. Check the cooling system frequently during freezing weather.

Checking & Adding Coolant

Refer to *Safety Precautions* on page 23.

1. With the engine cold, remove the radiator cap (1) and check coolant level. The coolant level is correct when it is at the bottom of the radiator filler neck (2).

⚠ WARNING

Removing the radiator cap while the engine is hot can cause the coolant to spray out, seriously scalding you.

Always let the engine and radiator cool down before removing the radiator cap.

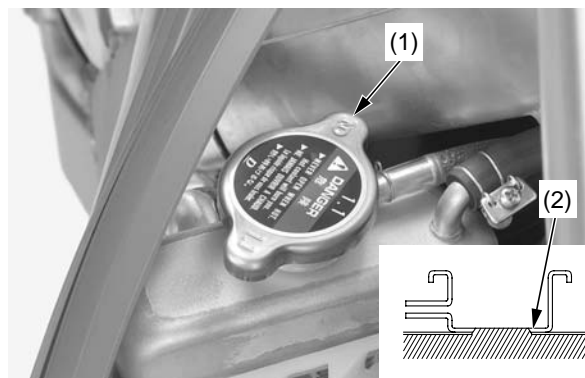

- (1) radiator cap
(2) radiator filler neck

2. Add coolant up to the filler neck if the level is low. Inspect the coolant level before each outing. A coolant loss of 0.7 - 2.0 US oz (20 - 60 cm³) through the overflow tube is normal. If coolant loss is more than this, inspect the cooling system.
Capacity:
1.12 US qt (1.06 ℓ) after disassembly
1.10 US qt (1.04 ℓ) after draining
3. Install the radiator cap securely.

NOTICE

If the radiator cap is not installed properly, it will cause excessive coolant loss and may result in overheating and engine damage.

Cooling System Inspection

1. Check the cooling system for leaks (see an official Honda Service Manual for troubleshooting of leaks).
2. Check the water hoses (1) for cracks, deterioration, and radiator hose clamps for looseness.
3. Check the radiator mount for looseness.
4. Make sure the overflow hose (2) is connected and not clogged.
5. Check the radiator fins (3) for clogging.

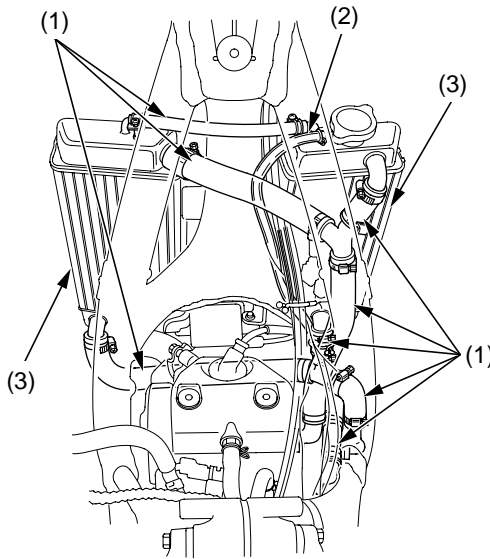

- (1) water hoses
(2) overflow hose
(3) radiator fins

6. Check the bleed hole (4) below the water pump cover (5) for leakage. Clean away any clogged dirt or sand, if necessary. Check for signs of seal leakage. If water leaks through the bleed hole, replace the mechanical seal. If oil leaks through the bleed hole, replace the oil seal. Make sure that there is no continuous coolant leakage from the bleed hole while operating the engine. A small amount of coolant weeping from the bleed hole is normal. See an official Honda Service Manual or consult your Honda dealer for replacing the mechanical seal or oil seal. Both seals should be replaced at the same time.

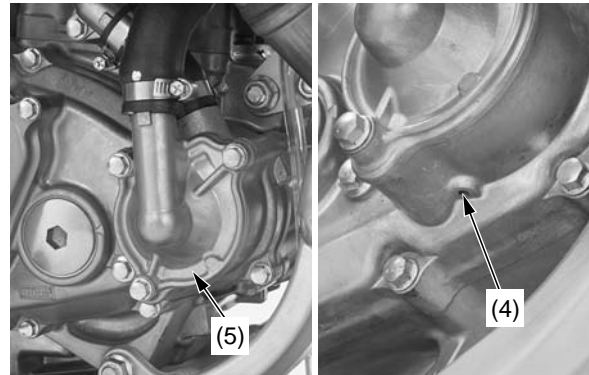

- (4) bleed hole
(5) water pump cover

Coolant Replacement

Refer to *Safety Precautions* on page 23.

Coolant should be replaced by your Honda dealer, unless you have the proper tools and service data and are mechanically qualified. Refer to an official Honda Service Manual (page 156).

⚠ WARNING

Removing the radiator cap while the engine is hot can cause the coolant to spray out, seriously scalding you.

Always let the engine and radiator cool down before removing the radiator cap.

To properly dispose of drained coolant, refer to *You & the Environment*, page 140.

NOTICE

Improper disposal of drained fluids is harmful to the environment.

Air Cleaner

Refer to *Safety Precautions* on page 23.

The air cleaner uses polyurethane inner and outer pieces which can't be separated. A dirty air cleaner will reduce engine power.

Proper air cleaner maintenance is very important for off-road vehicles. A dirty, water-soaked, worn-out, or defective air cleaner will allow dirt, dust, mud, and other impurities to pass into the engine.

Service the air cleaner more frequently if you ride in unusually wet or dusty areas. Your Honda dealer can help you determine the correct service interval for your riding conditions.

Your CRF's air cleaner has very specific performance requirements. Use a new Honda Genuine air cleaner specified for your model or an air cleaner of equal quality.

NOTICE

Using the wrong air cleaner may result in premature engine wear.

Proper air cleaner maintenance can prevent premature engine wear or damage, expensive repairs, low engine power, poor gas mileage, and spark plug fouling.

NOTICE

Improper or lack of proper air cleaner maintenance can cause poor performance and premature engine wear.

Cleaning

1. Remove the seat (page 33).
2. Remove the air cleaner retaining bolt (1) and air cleaner assembly (2).

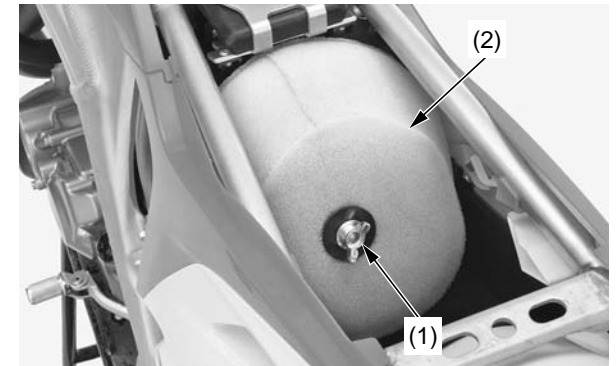

- (1) air cleaner retaining bolt
(2) air cleaner assembly

- Remove the air cleaner element (3) from the air cleaner holder (4) by releasing the holder tabs (5) from the holes (6) of the air cleaner element.

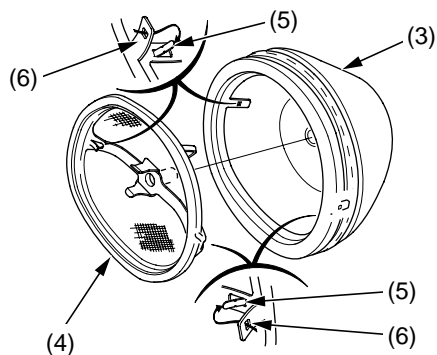

- (3) air cleaner element (5) holder tabs
(4) air cleaner holder (6) holes

- Wash the air cleaner in clean non-flammable cleaning solvent. Then wash in hot, soapy water, rinse well, and allow to dry thoroughly. The air cleaner element is made in two pieces: inner and outer, which cannot be separated.
- Clean the inside of the air cleaner housing.
- Allow the air cleaner to dry thoroughly. After drying, apply 50 cm³ of clean Pro Honda Foam Filter Oil or an equivalent air cleaner oil from the inside of the element. Place the element into a plastic bag (7) and spread the oil evenly by hand.

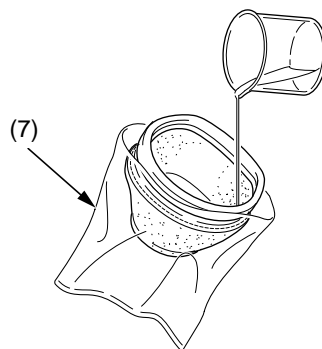

(7) plastic bag

- Assemble the air cleaner element and holder. Install the holder tabs (5) in the holes (6) of the air cleaner element.
- Apply 0.1 – 0.2 oz (3 – 5 g) of Pro Honda White Lithium Grease or equivalent to the air cleaner housing contact area of the air cleaner element.
- Install the air cleaner assembly (2) into the air cleaner housing by aligning its tabs (8) with the stay (9) of the air cleaner housing.
- Carefully position the sealing flange of the element to prevent dirt intrusion.

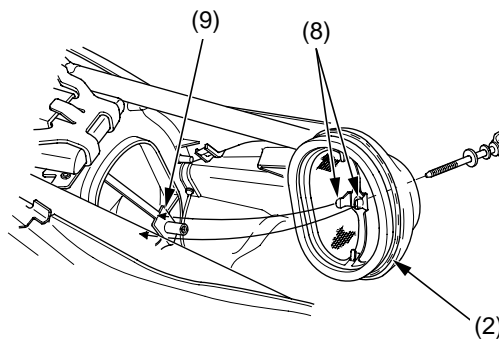

- (2) air cleaner assembly
(8) air cleaner assembly tabs
(9) air cleaner housing stay

- Install and tighten the air cleaner retaining bolt (1) securely.

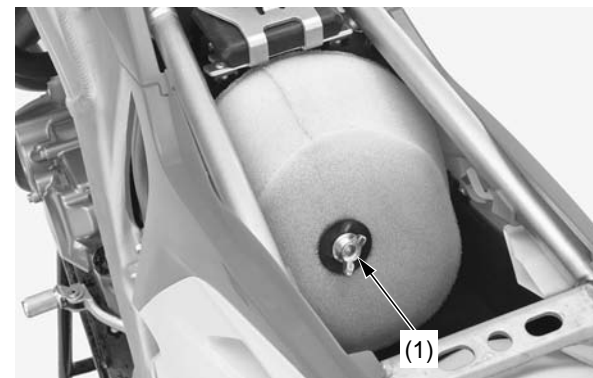

(1) air cleaner retaining bolt

NOTICE

Improper installation of the air cleaner assembly may allow dirt and dust to enter the engine and cause rapid wear of the piston rings and cylinder.

- Install the seat (page 33)

Crankcase Breather

Refer to *Safety Precautions* on page 23.

Service more frequently if your CRF is ridden in the rain or often at full throttle.

Service the breather if you can see deposits in the transparent section of the drain tube.

Draining

1. Remove the crankcase breather tube plug (1) from the crankcase breather tube (2) and drain deposits into a suitable container.
2. Reinstall the crankcase breather tube plug.

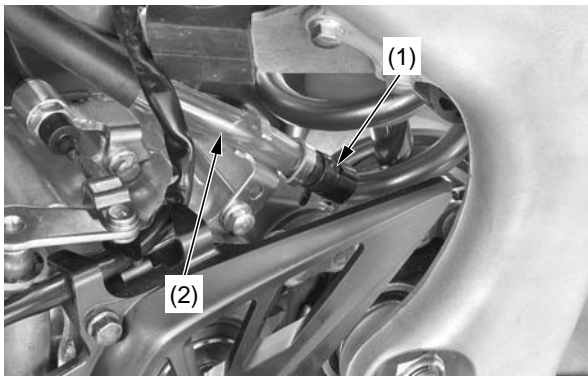

- (1) crankcase breather tube plug
(2) crankcase breather tube

Refer to *Safety Precautions* on page 23.

Throttle Freeplay

Inspection

Check freeplay (1).

Freeplay: 1/8 – 3/16 in (3 – 5 mm)

If necessary, adjust to the specified range.

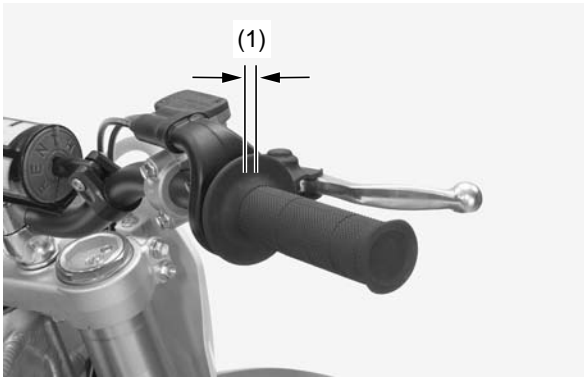

(1) freeplay

Upper Adjustment

Minor adjustments are generally made with the upper adjuster.

1. Pull the dust cover (2) back.
2. Loosen the lock nut (3).
3. Turn the adjuster (4).
Turning the adjuster in direction (–) will decrease freeplay and turning it in direction (+) will increase freeplay.

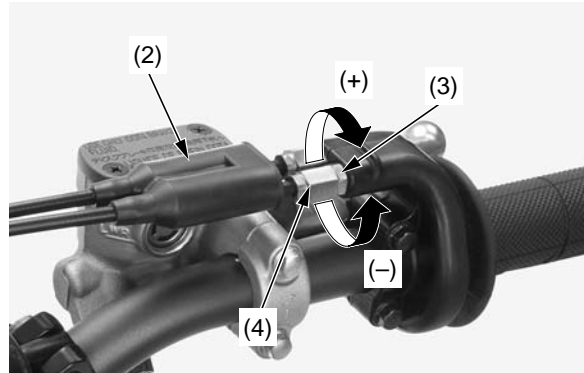

(2) dust cover
(3) lock nut
(4) adjuster
(+) increase
(–) decrease

4. Tighten the lock nut to the specified torque:
3.0 lbf·ft (4 N·m, 0.4 kgf·m)
Return the dust cover to its normal position.
5. After adjustment, check for smooth rotation of the throttle grip from fully closed to fully open in all steering positions.
If the adjuster is threaded out near its limit or the correct freeplay cannot be reached, turn the adjuster all the way in and back out one turn.
Tighten the lock nut to the specified torque:
3.0 lbf·ft (4 N·m, 0.4 kgf·m)
Install the dust cover and make the adjustment with the lower adjuster.

Lower Adjustment

The lower adjuster is used for major freeplay adjustment, such as after replacing the throttle cables or removing the throttle body. It is also used if you cannot get the proper adjustment with the upper adjuster.

1. Hang the fuel tank to the left side of the frame (page 34).
2. Loosen the lock nut (1).
3. Turn the adjuster (2) in direction (–) to decrease freeplay, and in direction (+) to increase freeplay.

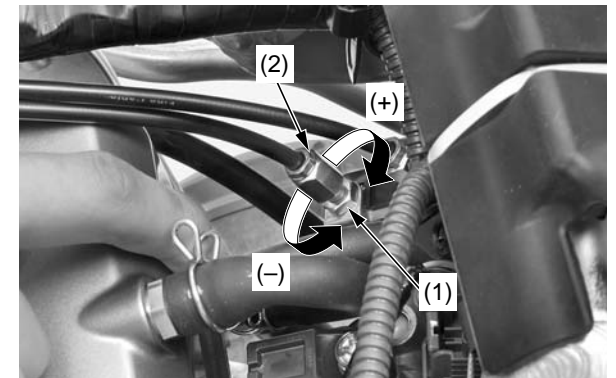

(1) lock nut
(2) adjuster
(+) increase freeplay
(–) decrease freeplay

4. Tighten the lock nut to the specified torque:
3.0 lbf·ft (4 N·m, 0.4 kgf·m)
5. Operate the throttle grip to ensure that it functions smoothly and returns completely.
6. Install the fuel tank (page 35).

If you can't get the freeplay within the specified range, contact your Honda dealer.

Throttle

Throttle Inspection

1. Check that the throttle assembly is positioned properly (the end of the throttle housing (1) is aligned with the paint mark (2) on the handlebar) and the securing bolts are tight.

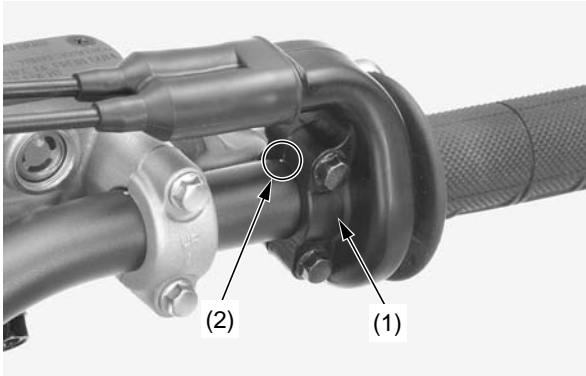

(1) throttle housing (2) paint mark

2. Check for smooth rotation of the throttle (3) from fully open to fully closed in all steering positions. If there is a problem, see your Honda dealer.

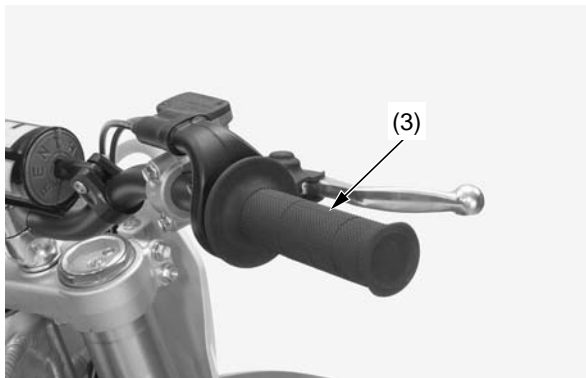

(3) throttle

3. Inspect the condition of the throttle cables from the throttle grip down to the throttle body. If the cable is kinked or chafed, have it replaced.
4. Check the cables for tension or stress in all steering positions.
5. Lubricate the cables with a commercially available cable lubricant to prevent premature rust and corrosion.

Refer to *Safety Precautions* on page 23.

Remember, idle speed adjustment is not a “cure-all” for other problems in your engine’s PGM-FI system. Adjusting the idle will not compensate for a fault elsewhere.

The engine must be at normal operating temperature for accurate idle speed adjustment. When pushed in, the fast idle knob acts as the idle adjust screw.

Turning it counterclockwise results in a faster/higher idle speed.

Turning it clockwise results in a slower/lower idle speed.

Idle Speed Adjustment

1. If the engine is cold, start it and warm it up 3 minutes. Then shut it off.
2. Connect a tachometer to the engine.
3. Shift the transmission into neutral. Start the engine.
4. Keep the motorcycle in an upright position.
5. Adjust idle speed with the fast idle knob (1).
Idle speed: $1,800 \pm 100$ rpm

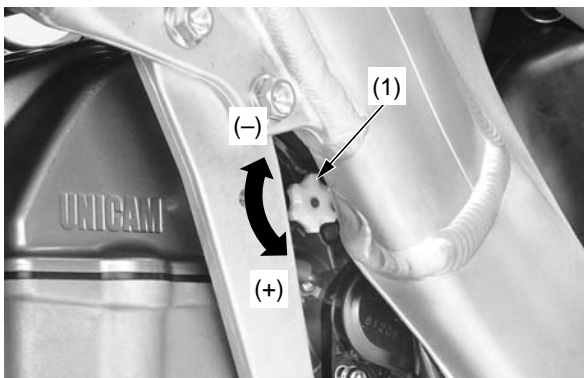

- (1) fast idle knob
(+) increase
(-) decrease

Clutch System

Refer to *Safety Precautions* on page 23.

Clutch Lever Adjustment

The distance between the tip of the clutch lever and the grip may be adjusted.

Make sure to adjust the clutch lever freeplay after the clutch lever position adjustment or clutch cable disconnected.

1. Loosen the lock nut (1).
2. To position the clutch lever farther away from the handgrip, turn the adjuster (2) counterclockwise. To position the brake lever closer to the handgrip, turn the adjuster clockwise.
3. Tighten the lock nut.

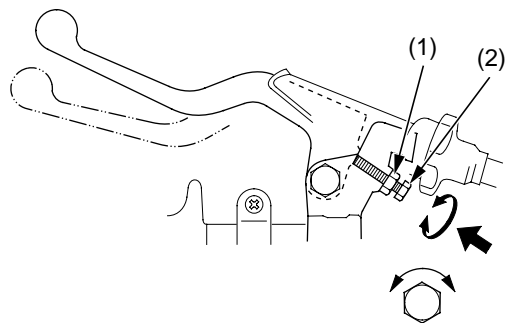

(1) lock nut

(2) adjuster

4. Turn the cable end adjuster (3) in direction (+) until it seats lightly and then turn it out five turns.

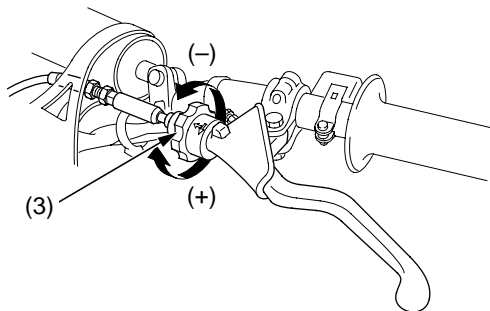

- (3) cable end adjuster
(+) increase freeplay
(-) decrease freeplay

5. Loosen the lock nut (4) and turn the integral cable adjuster (5) to adjust the clutch lever freeplay at the tip of lever.
Freeplay: 3/8 – 13/16 in (10 – 20 mm)
Tighten the lock nut.

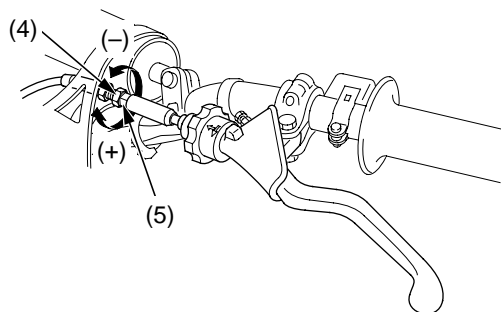

- (4) lock nut
(5) integral cable adjuster
(+) increase freeplay
(-) decrease freeplay

6. Adjust the cable end adjuster for minor adjustment (page 59).

Clutch Lever Freeplay

Inspection

Check freeplay (1).

Freeplay: 3/8 – 13/16 in (10 – 20 mm)

If necessary, adjust to the specified range.

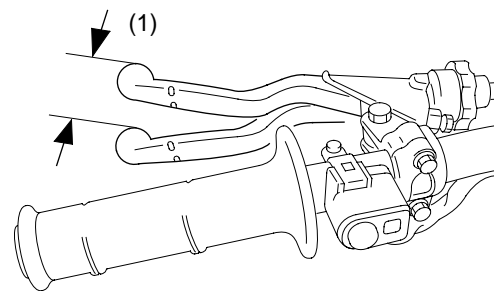

(1) freeplay

Improper freeplay adjustment can cause premature clutch wear.

Make sure to adjust the clutch lever freeplay after the clutch cable is disconnected.

Cable End Adjustment

Minor adjustments are generally made with the clutch cable end adjuster.

Turning the cable end adjuster (1) in direction (+) will increase freeplay and turning it in direction (-) will decrease freeplay.

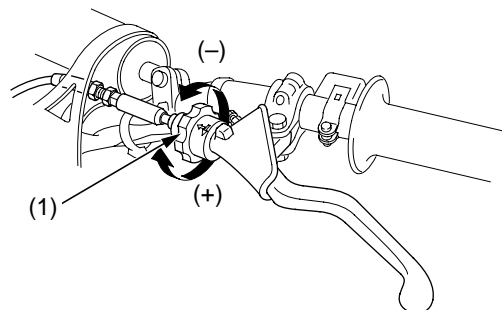

(1) cable end adjuster
 (+) increase freeplay
 (-) decrease freeplay

If the adjuster is threaded out near its limit or the correct freeplay cannot be reached, turn the adjuster all the way in and back out one turn and make the adjustment with the integral cable adjuster.

Integral Cable Adjustment

The integral cable adjuster is used if the cable end adjuster is threaded out near its limit — or the correct freeplay cannot be obtained.

1. Turn the cable end adjuster in direction (+) until it seats lightly and then turn it out five turns.
2. Loosen the lock nut (1).
3. Turn the integral cable adjuster (2) to obtain the specified freeplay.
4. Tighten the lock nut. Check the freeplay.

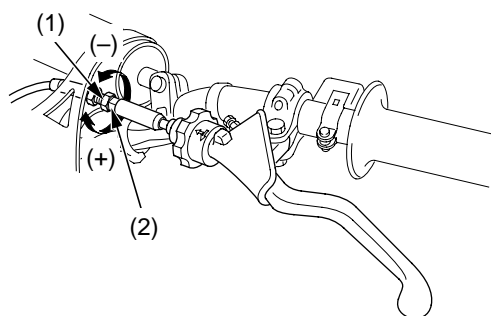

(1) lock nut
 (2) integral cable adjuster
 (+) increase freeplay
 (-) decrease freeplay

5. Start the engine, pull the clutch lever in, and shift into gear. Make sure the engine does not stall and the motorcycle does not creep. Gradually release the clutch lever and open the throttle. Your CRF should move smoothly and accelerate gradually.

If you can't get proper adjustment, or the clutch does not work properly, the cable may be kinked or worn, or the clutch discs may be worn. Inspect the clutch discs and plates (page 61).

Other Inspections & Lubrication

- Check that the clutch lever assembly is positioned properly (the end of the holder (1) is aligned with the paint mark (2) on the handlebar) and the securing bolts are tight.

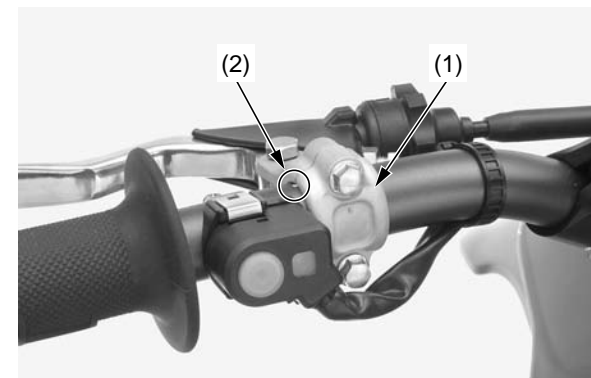

(1) holder
 (2) paint mark

- Check the clutch cable for kinks or signs of wear. If necessary, have it replaced.
- Lubricate the clutch cable with a commercially available cable lubricant to prevent premature wear and corrosion.

Clutch Operation

1. Check for smooth clutch lever operation. If necessary, lubricate the clutch lever pivot bolt sliding surface with grease and/or clutch cable with commercially available cable lubricant.
2. Check the clutch cable for deterioration, kinks, or damage.

Clutch System

Clutch Disc/Plate Removal

1. Drain the transmission oil (page 49).
2. Remove the rear brake pedal (1) by removing its pivot bolt (2), washer and dust seals (3).

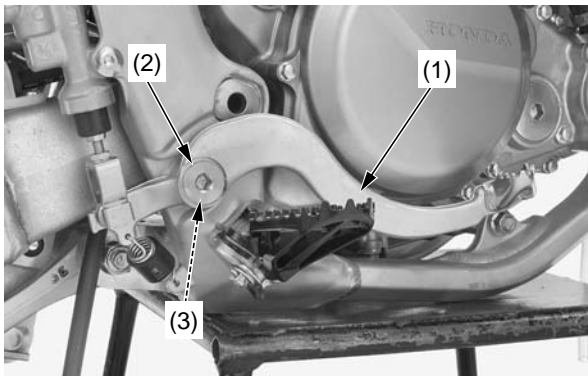

(1) rear brake pedal (3) washer and dust seals
(2) brake pedal pivot bolt

3. Remove the five clutch cover bolts (4) and clutch cover (5).

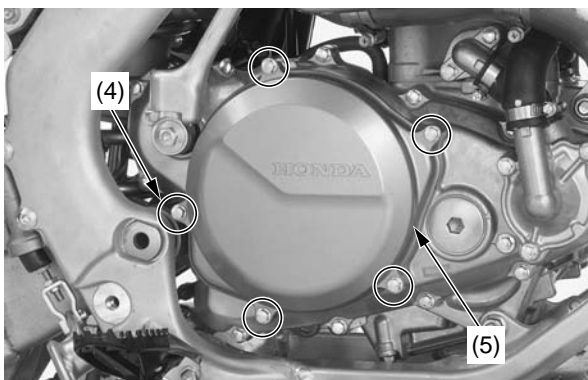

(4) clutch cover bolts (5) clutch cover

4. Remove the four clutch spring bolts and springs (6).

Loosen the bolts in a crisscross pattern in two or three progressive steps.

5. Remove the clutch pressure plate (7).

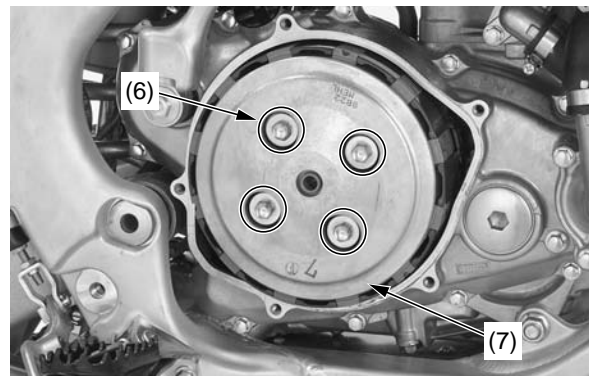

(6) clutch spring bolts and springs
(7) clutch pressure plate

6. Remove the washer (8), needle bearing (9), clutch lifter (10) and clutch lifter rod (11).

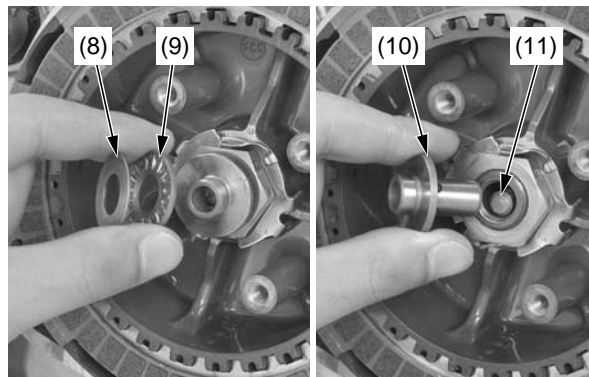

(8) washer (10) clutch lifter
(9) needle bearing (11) clutch lifter rod

7. Assemble the clutch lifter, needle bearing and washer. Turn the needle bearing with your finger. The needle bearing should turn smoothly and quietly. Replace the needle bearing and washer if the needle bearing does not turn smoothly.

8. Remove the eight clutch discs and seven clutch plates (12).

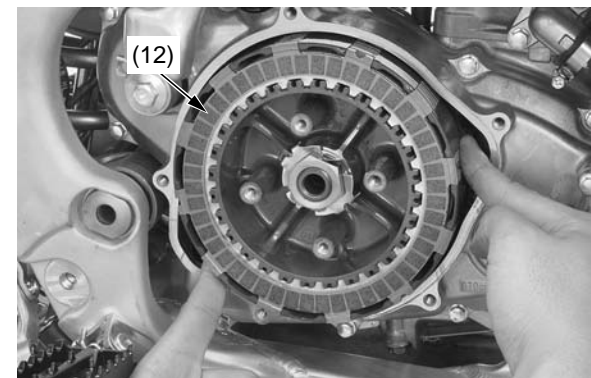

(12) clutch discs and plates

Clutch Disc/Plate Inspection

Replace the clutch discs (1) if they show signs of scoring or discoloration.

Measure the thickness of each clutch disc.

Service Limit: 0.112 in (2.85 mm)

Replace the clutch discs and clutch plates as a set.

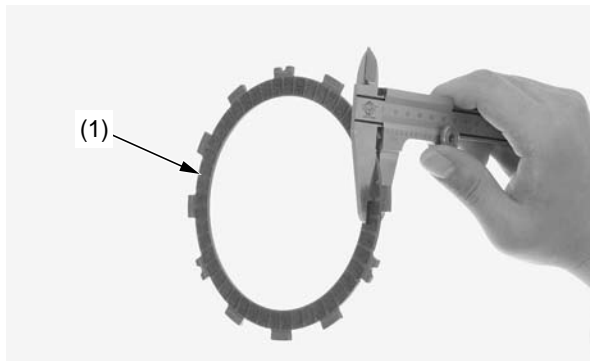

(1) clutch disc

Check the clutch plates (2) for excessive warpage or discoloration.

Check the plate warpage on a surface plate using a feeler gauge.

Service Limit: 0.006 in (0.15 mm)

Replace the clutch discs and plates as a set.



(2) clutch plate

If you feel the clutch slippage when replacing the clutch discs and plates, replace the clutch springs.

Clutch Disc/Plate Installation

1. Coat the clutch discs with engine oil.
2. Install the eight clutch discs (1) and seven clutch plates (2) alternately, starting with a disc.

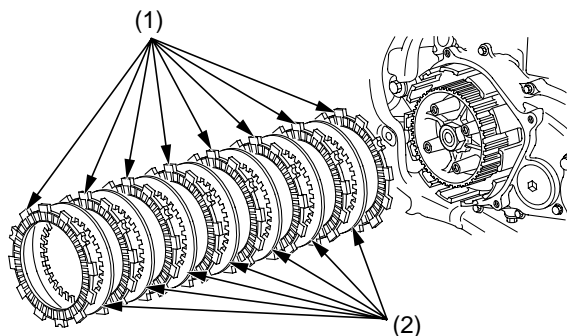

(1) eight clutch discs
(2) seven clutch plates

3. Insert the clutch lifter rod (3) into the mainshaft.
4. Apply engine oil to the needle bearing (4) and washer (5) and install them onto the clutch lifter (6).
5. Install the clutch lifter onto the rod.

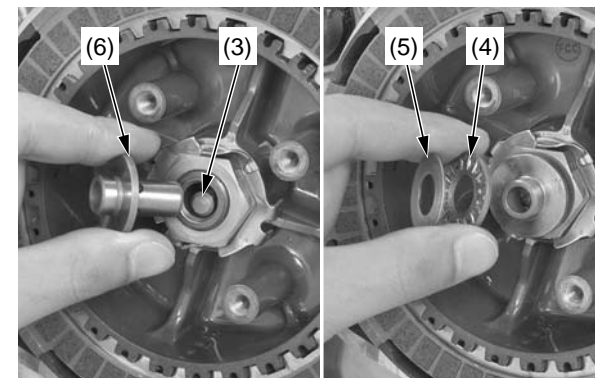

(3) clutch lifter rod
(4) needle bearing
(5) washer
(6) clutch lifter

6. Install the clutch pressure plate (7).
7. Install the four clutch springs and bolts (8).
8. Tighten the bolts in a crisscross pattern in two or three steps to the specified torque:
9 lbf-ft (12 N·m, 1.2 kgf·m)

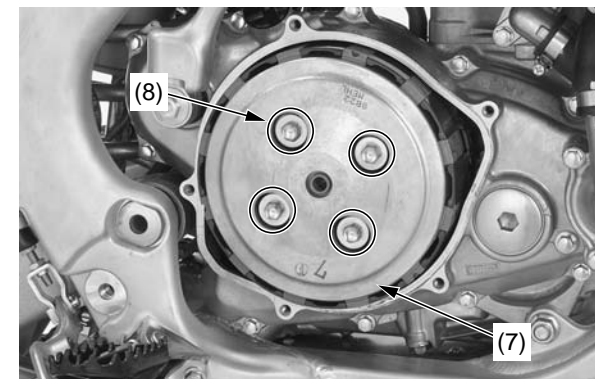

(7) clutch pressure plate
(8) clutch springs and bolts

(cont'd)

Clutch System

9. Apply oil to a new O-ring (9) and install it in the groove of the clutch cover (10).
10. Install the cover by tightening the five cover bolts in a crisscross pattern in two or three steps to the specified torque:
7 lbf·ft (10 N·m, 1.0 kgf·m)

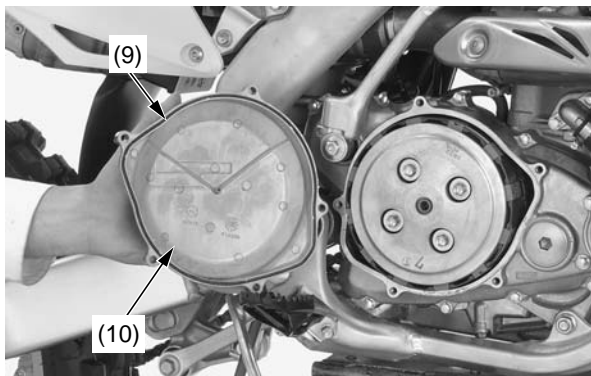

(9) O-ring (new) (10) clutch cover

11. Lubricate the dust seals (11) and rear brake pedal pivot bolt (12) with urea based multi-purpose grease or equivalent.
12. Apply locking agent to the brake pedal pivot bolt threads.
13. Install the dust seals into the rear brake pedal (13).

14. Install the pivot bolt with the washer (14) and tighten the pivot bolt to the specified torque:
27 lbf·ft (36 N·m, 3.7 kgf·m)
Connect the brake pedal return spring (15) if it is removed.

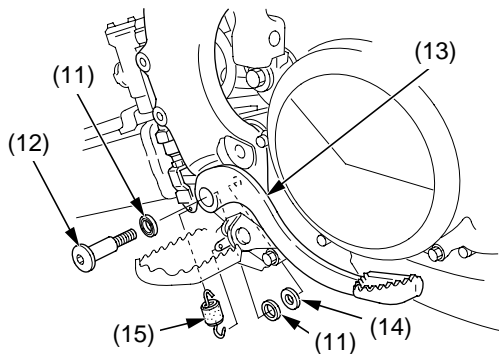

(11) dust seals (14) washer
(12) brake pedal pivot bolt (15) brake pedal return spring
(13) rear brake pedal

15. Fill the crankcase with transmission oil (page 49).

Refer to *Safety Precautions* on page 23.

Spark Plug Recommendation

The recommended standard spark plug is satisfactory for most racing conditions.

Standard	SILMAR9A – 9S (NGK)
Optional	SILMAR10A – 9S (NGK)

Use only the recommended type of spark plugs in the recommended heat range.

NOTICE

Using a spark plug with an improper heat range or incorrect reach can cause engine damage. Using a non-resistor spark plug may cause ignition problems.

This motorcycle uses spark plug that have an iridium tip in the center electrode and a platinum tip in the side electrode.

Be sure to observe the following when servicing the spark plug.

- Do not clean the spark plug. If an electrode is contaminated with accumulated objects or dirt, replace the spark plug with a new one.
- To check the spark plug gap, use only a “wire-type feeler gauge.” To prevent damaging the iridium tip of the center electrode and platinum tip of the side electrode, never use a “leaf-type feeler gauge.”
- Do not adjust the spark plug gap. If the gap is out of specification, replace the spark plug with a new one.

Spark Plug Inspection & Replacement

1. Remove the seat and hang the fuel tank to the left of the frame (pages 33, 34).
2. Disconnect the spark plug cap (1).
3. Clean any dirt from around the spark plug base.
4. Remove the spark plug (2).

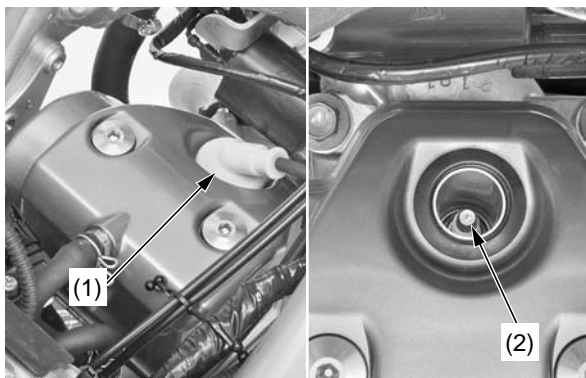

(1) spark plug cap (2) spark plug

5. Check the electrodes for wear or deposits, the sealing gasket (3) for damage, and the insulator for cracks. Replace if you detect them.
6. Check the spark plug gap (4), using a wire-type feeler gauge. If the gap is out of specifications, replace the plug with a new one.

The recommended spark plug gap is:
0.031 – 0.035 in (0.8 – 0.9 mm)

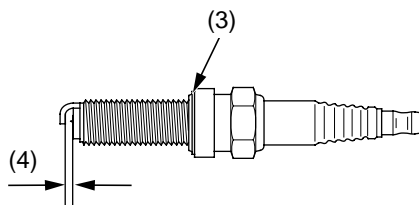

(3) sealing gasket
(4) spark plug gap

7. To obtain accurate spark plug readings, accelerate up to speed on a straightaway. Press and hold the engine stop button and disengage the clutch by pulling the lever in. Coast to a stop, then remove and inspect the spark plug. The porcelain insulator around the center electrode should appear tan or medium gray. If you're using a new plug, ride for at least 10 minutes before taking a plug reading; a brand-new plug will not color initially. If the electrodes appear burnt, or the insulator is white or light gray (lean) or the electrodes and insulator are black or fouled (rich), there is a problem elsewhere (page 130). Check the PGM-FI system and ignition timing.

8. With the sealing gasket attached, thread the spark plug in by hand to prevent cross-threading.
9. Tighten the spark plug.
 - If the old plug is good: 1/12 turn after it seats.
 - If installing a new plug, tighten it twice to prevent loosening:
 - a) First, tighten the plug: NGK: 1/4 turn after it seats.
 - b) Then loosen the plug.
 - c) Next, tighten the plug again: 1/12 turn after it seats.

NOTICE

An improperly tightened spark plug can damage the engine. If a plug is too loose, a piston may be damaged. If a plug is too tight, the threads may be damaged.

10. Connect the spark plug cap. Take care to avoid pinching any cables or wires.
11. Install the fuel tank and seat (pages 33, 35).

Valve Clearance

Refer to *Safety Precautions* on page 23.

Excessive valve clearance will cause noise and eventual engine damage. Little or no clearance will prevent the valve from closing and cause valve damage and power loss. Check valve clearance when the engine is cold at the intervals specified in the Maintenance Schedule (page 25).

The checking or adjusting of the valve clearance should be performed while the engine is cold. The valve clearance will change as engine temperature rises.

Cylinder Head Cover Removal

Before inspection, clean the engine thoroughly to keep dirt from entering the engine.

1. Remove the seat and hang the fuel tank to the left of the frame (pages 33, 34).
2. Disconnect the breather tube (1) and spark plug cap (2).

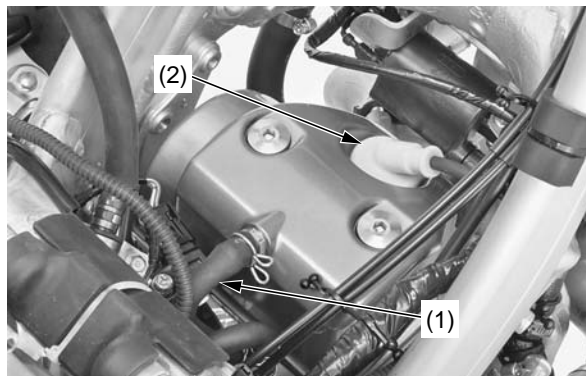

(1) breather tube (2) spark plug cap

3. Remove the cylinder head cover socket bolts (3), rubber seals (4) and cylinder head cover (5).

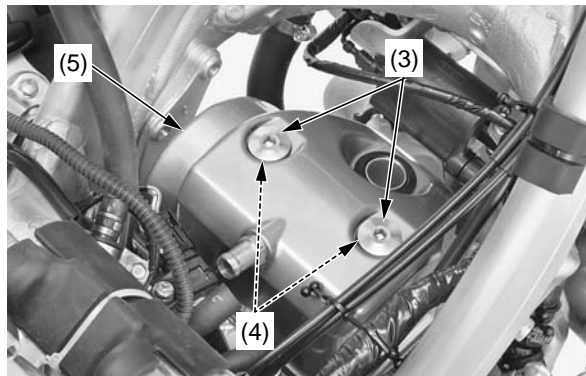

(3) cylinder head cover socket bolts
(4) cylinder head cover rubber seals
(5) cylinder head cover

Positioning At TDC On The Compression Stroke

1. Remove the crankshaft hole cap (1).

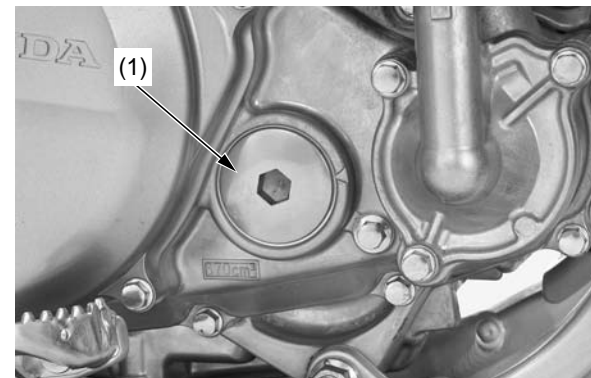

(1) crankshaft hole cap

2. Remove the spark plug (page 63).
3. Remove the cylinder head cover (page 64).

4. Rotate the crankshaft by turning the primary drive gear bolt (2) clockwise until the punch mark (3) on the primary drive gear aligns with the index mark (4) on the right crankcase cover. In this position, the piston may either be on the compression or exhaust stroke.

If the crankshaft passed the punch mark, rotate the primary drive gear bolt clockwise again and align the punch mark with the index mark.

The inspection must be made when the piston is at the top of the compression stroke when both the intake and exhaust valves are closed. This condition can be determined by moving the exhaust rocker arms (5). If they are free, an indication that the valves are closed and that the piston is on the compression stroke. If they are tight and the valves are open, rotate the primary drive gear bolt 360° and realign the punch mark with the index mark.

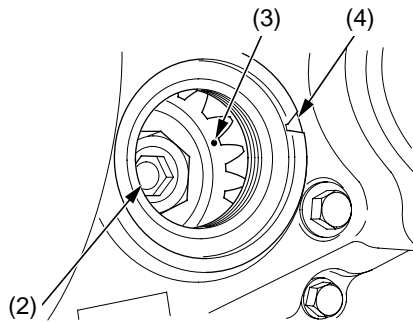

- (2) primary drive gear bolt
(3) punch mark
(4) index mark

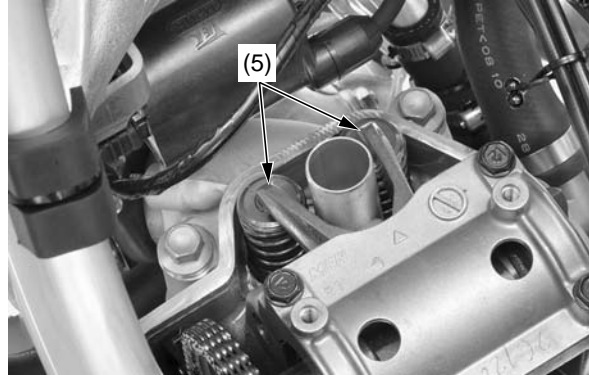

(5) exhaust rocker arms

Valve Clearance Inspection

1. Set the piston at TDC on the compression stroke (page 64).
2. Measure the intake valve clearance by inserting a feeler gauge (1) between the valve lifters and cam lobes (2).

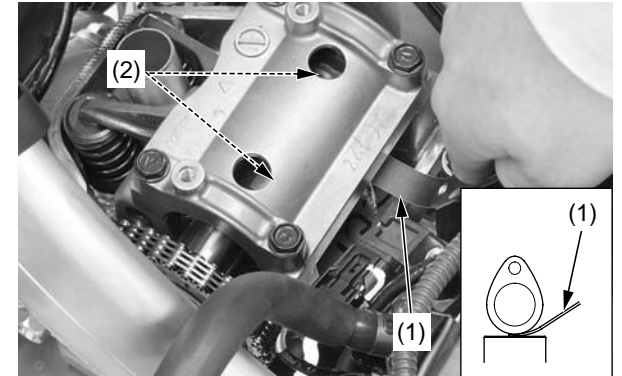

- (1) feeler gauge
(2) valve lifters and cam lobes

(cont'd)

Valve Clearance

3. Measure the exhaust valve clearance by inserting a feeler gauge (1) between the exhaust rocker arms (3) and shims (4).

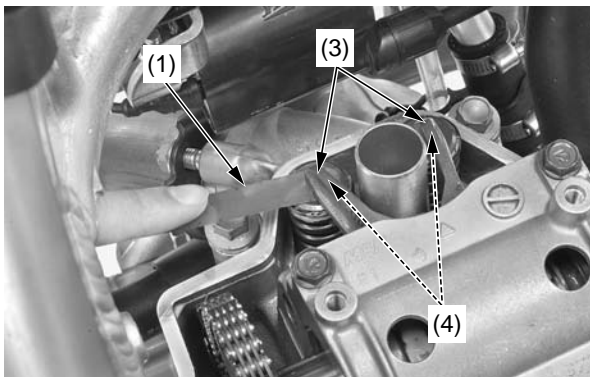

- (1) feeler gauge
- (3) exhaust rocker arms
- (4) exhaust valve shims

Valve Clearance:

IN: 0.006 ± 0.001 in (0.16 ± 0.03 mm)

EX: 0.011 ± 0.001 in (0.28 ± 0.03 mm)

If intake valve clearance and exhaust valve clearance need adjustment, see *Camshaft Removal* (this page) and select the correct shim for each valve.

Camshaft Removal

1. Record the intake valve and exhaust valve clearances (page 65).
Make sure the piston is at TDC on the compression stroke (page 64).
2. Remove the cam chain tensioner lifter cover bolt (1) and sealing washer (2).

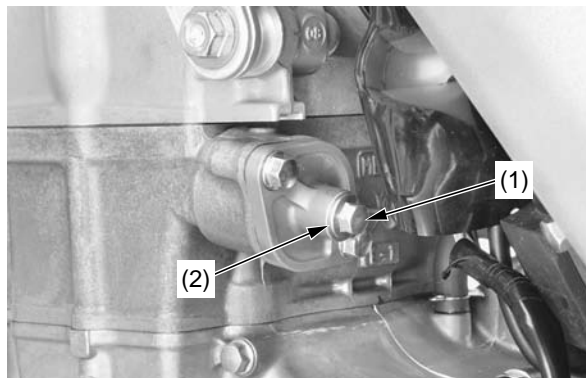

- (1) cam chain tensioner lifter cover bolt
- (2) sealing washer

3. Insert the tensioner stopper (3) into the cam chain tensioner lifter (4).
Turn the tensioner stopper clockwise and lock the cam chain tensioner lifter by pushing the handle (5) to the cam chain tensioner lifter.
- Tensioner stopper 070MG-0010100

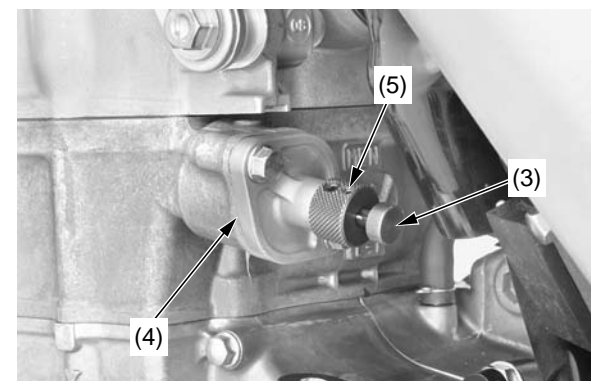

- (3) tensioner stopper
- (4) cam chain tensioner lifter
- (5) handle

4. Make sure the piston is at TDC on the compression stroke (page 64).
Loosen the camshaft holder bolts (6) in a crisscross pattern in two or three steps.
Remove the camshaft holder bolts, set rings (7) and camshaft holder (8).
As you remove the camshaft holder, set rings may be sticking in the camshaft holder.

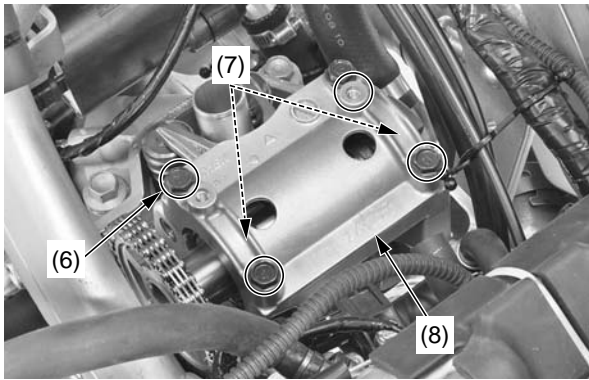

- (6) camshaft holder bolts
(7) set rings
(8) camshaft holder

NOTICE

Do not let the set rings fall into the crankcase.

If the set rings are remained on the camshaft holder, remove the set rings carefully.

5. Slide the left camshaft bearing (9) and remove the camshaft (10) and cam chain (11).

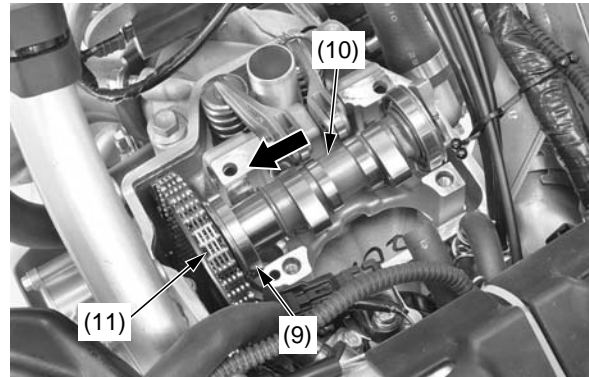

- (9) left camshaft bearing
(10) camshaft
(11) cam chain

6. Remove the intake valve lifters (12).
Keep the intake valve lifters and shims separate so you can easily identify the originally installed location such as intake or exhaust, right or left.

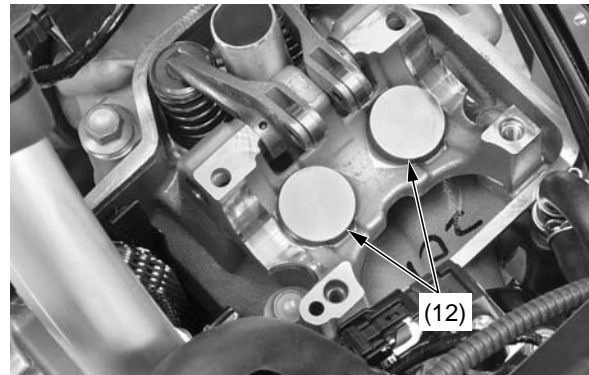

- (12) intake valve lifters

7. Remove the valve shims (13).

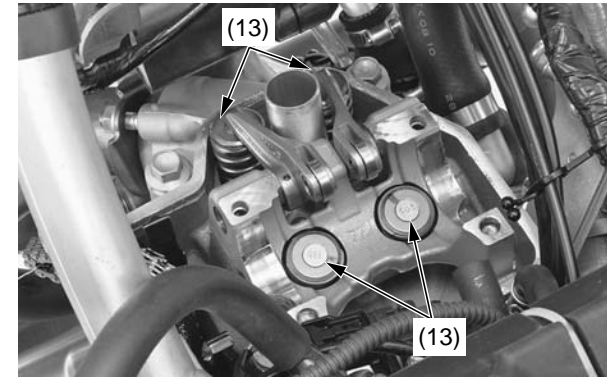

- (13) valve shims

Valve Clearance

Shim Selection

1. Clean the valve shim contact area in the valve lifter (1) with compressed air.

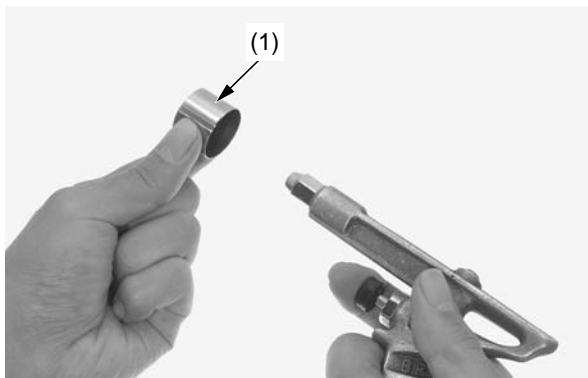

(1) valve lifter

2. Measure the shim thickness with a micrometer and record it.
Seventy-three different shims (2) are available in 0.025 mm thickness intervals, from 1.200 mm (the thinnest) to 3.000 mm (the thickest).

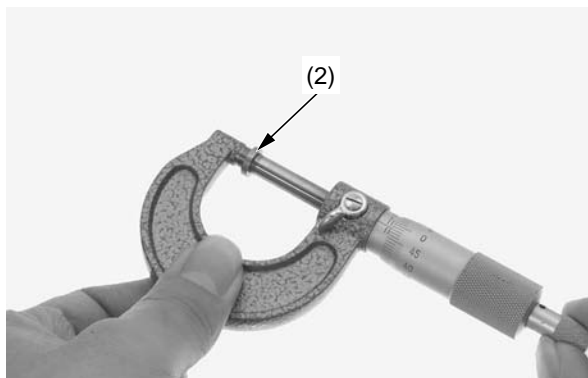

(2) shim

3. Calculate the new shim thickness using the equation below.

$$A = (B - C) + D$$

- A: New shim thickness
B: Recorded valve clearance
C: Specified valve clearance
D: Old shim thickness

- Make sure of the correct shim thickness by measuring the shim with a micrometer.
- Reface the intake valve seat if carbon deposits result in a calculated dimension of over 2.450 mm.
Reface the exhaust valve seat if carbon deposits result in a calculated dimension of over 3.000 mm.

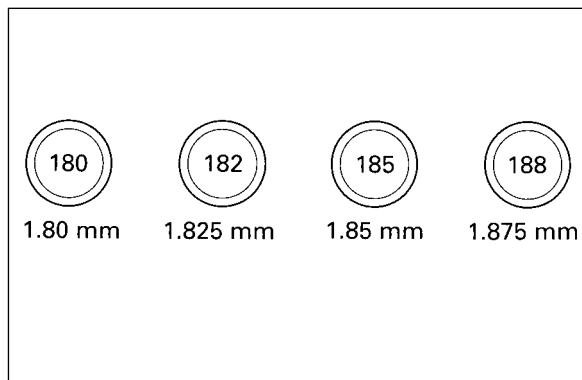

Camshaft Installation

1. Install the newly selected shims (1) on the valve spring retainers (2).

NOTICE

Do not let the shims fall into the crankcase.

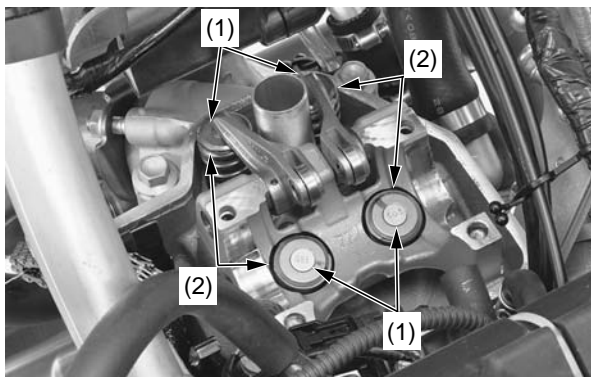

- (1) shims
- (2) valve spring retainers

2. Apply molybdenum disulfide oil (a mixture of 1/2 engine oil and 1/2 molybdenum disulfide grease containing more than 3% molybdenum disulfide additive) to the following parts.
 - camshaft cam lobes
 - each valve lifter outer surface
 - plunger whole surface

3. Install each valve lifter (3) in their original location into the cylinder head (4).

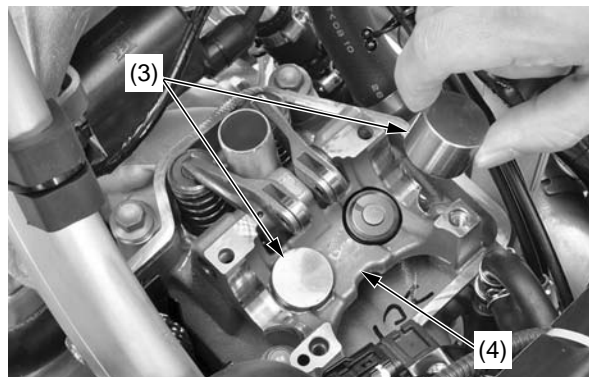

- (3) valve lifters
- (4) cylinder head

4. Check the operation of the plunger (5) by turning the decompressor weight (6) with your finger; The plunger should be retracted and protruded smoothly.

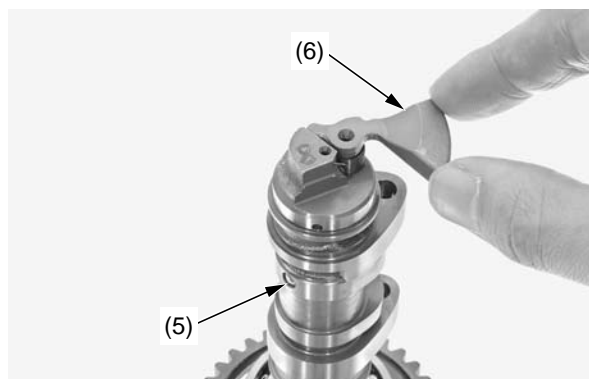

- (5) plunger
- (6) decompressor weight

If the operation is not smooth, refer to an official Honda Service Manual (page 156) for decompressor disassembly or see your Honda dealer.

5. Make sure the piston is at TDC on the compression stroke (page 64).
6. Install the camshaft (7) onto the cylinder head with intake cam lobes (8) facing up as illustrated below.

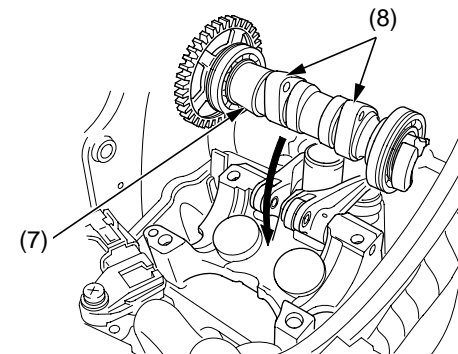

- (7) camshaft
- (8) intake cam lobes

7. Install the cam chain (9) over the cam sprocket (10). While holding the left camshaft bearing (11) to the left fully, install the camshaft (7) onto the cylinder head (4).

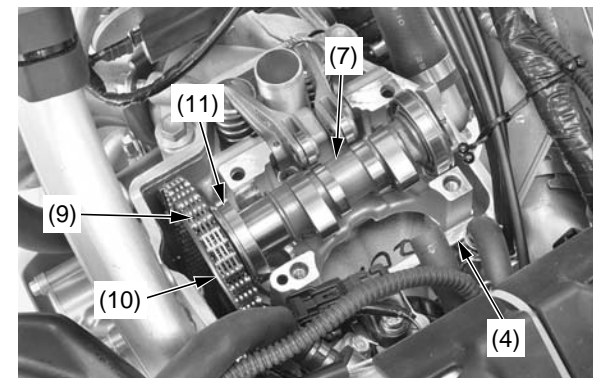

- (4) cylinder head
- (7) camshaft
- (9) cam chain
- (10) cam sprocket
- (11) left camshaft bearing

(cont'd)

Valve Clearance

8. Make sure that the timing mark (12) on the cam sprocket aligns with the camshaft holder mating surface (13) of the cylinder head.

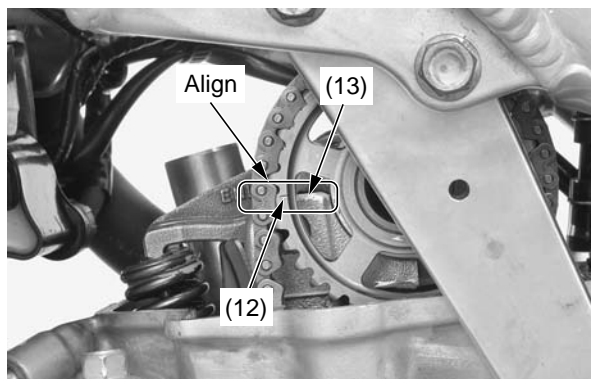

(12) timing mark
(13) camshaft holder mating surface

9. Make sure that the dowel pins (14) are installed into the camshaft holder (15).

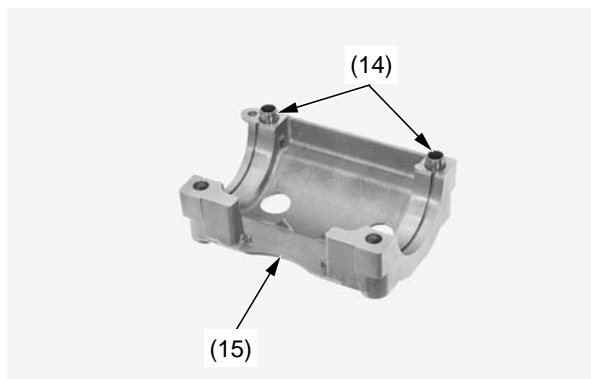

(14) dowel pins (15) camshaft holder

10. Install the set rings (16) on the camshaft bearing grooves (17).

NOTICE

Do not let the set rings fall into the crankcase.

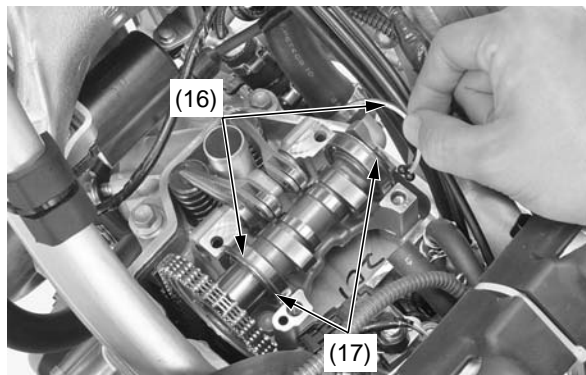

(16) set rings (17) camshaft bearing grooves

11. Apply engine oil to the camshaft holder bolt threads and seating surface. Install the camshaft holder (18) with the “Δ” mark (19) facing forward. Tighten the camshaft holder bolts (20) (21) to the specified torque:
10 lbf-ft (14 N·m, 1.4 kgf·m)
Tighten the camshaft holder bolts in a criss-cross pattern in two or three steps.

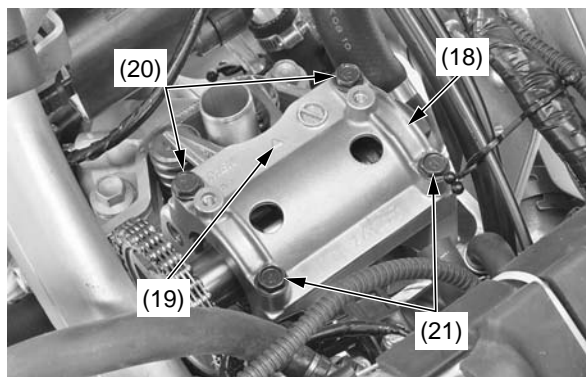

(18) camshaft holder (19) “Δ” mark (20) camshaft holder bolts (long) (21) camshaft holder bolts (short)

12. Remove the tensioner stopper (22) from the cam chain tensioner lifter.

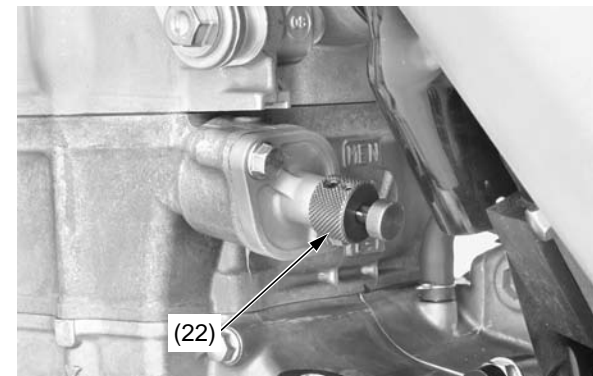

(22) tensioner stopper

13. Make sure that the piston is at TDC on the compression stroke (page 64). Check that the timing mark (12) on the cam sprocket aligns with the camshaft holder mating surface (13) of the cylinder head. If the timing mark doesn't align with the camshaft holder mating surface, remove the cam chain and realign the timing mark.

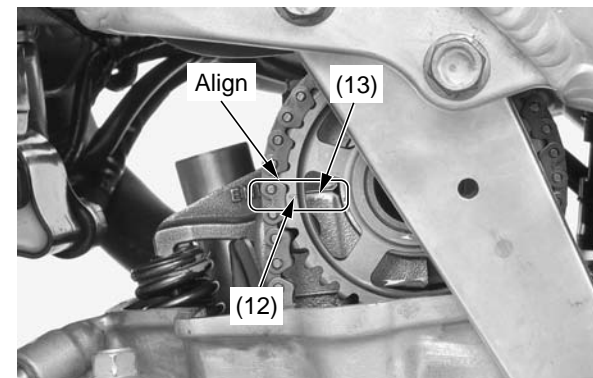

(12) timing mark
(13) camshaft holder mating surface

14. Measure the intake valve and exhaust valve clearances by inserting a feeler gauge (23).

Valve Clearance:

IN: 0.006 ± 0.001 in (0.16 ± 0.03 mm)

EX: 0.011 ± 0.001 in (0.28 ± 0.03 mm)

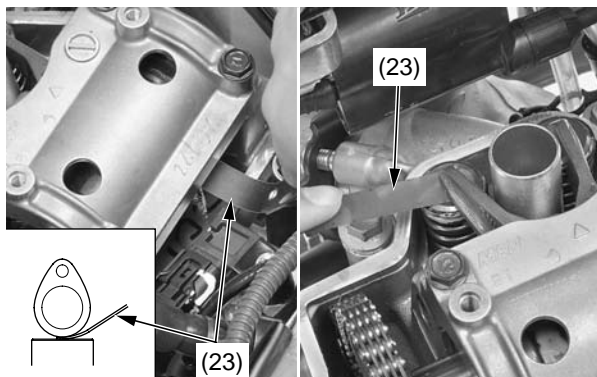

(23) feeler gauge

15. Install a new sealing washer (24) and tighten the cam chain tensioner lifter cover bolt (25).

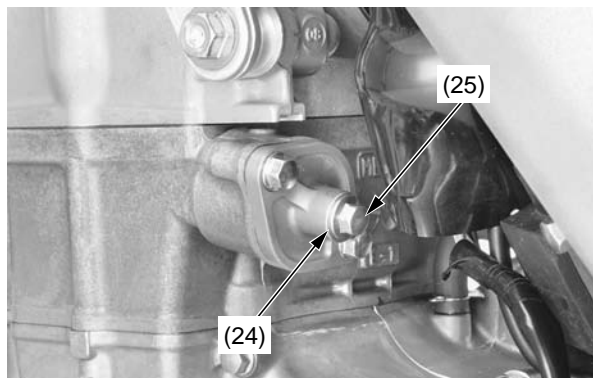

(24) sealing washer (new)

(25) cam chain tensioner lifter cover bolt

Crankshaft Hole Cap Installation

1. Install the spark plug (page 63).
2. Coat a new O-ring (1) with engine oil and install it onto the crankshaft hole cap (2). Apply grease to the crankshaft hole cap threads. Install and tighten the crankshaft hole cap to the specified torque:
11 lbf·ft (15 N·m, 1.5 kgf·m)

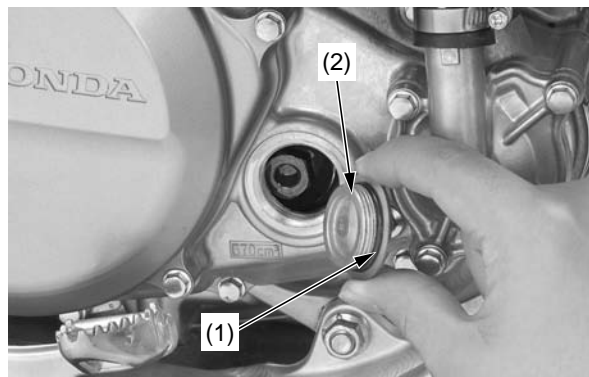

(1) O-ring (new)

(2) crankshaft hole cap

Cylinder Head Cover Installation

1. Check that the spark plug hole packing (1) is in good condition and replace it if necessary. Apply engine oil to the spark plug hole packing and install it to the cylinder head cover (2).
2. Check that the cylinder head cover packing (3) is in good condition and replace it if necessary. Install the cylinder head cover packing into the cylinder head cover groove.

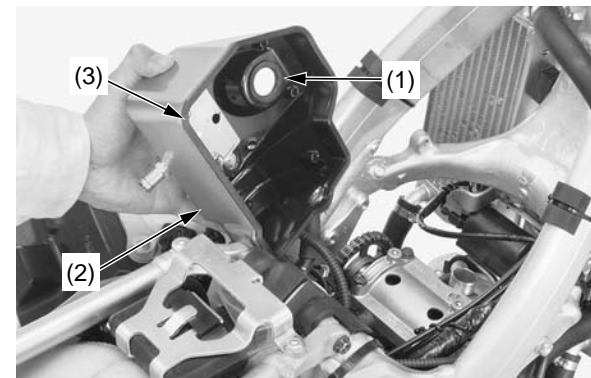

(1) spark plug hole packing

(2) cylinder head cover

(3) cylinder head cover packing

(cont'd)

Valve Clearance

3. Check that the rubber seals (4) are in good condition, replace them if necessary. Install the rubber seals onto the cylinder head cover with the “UP” marks (5) facing up.

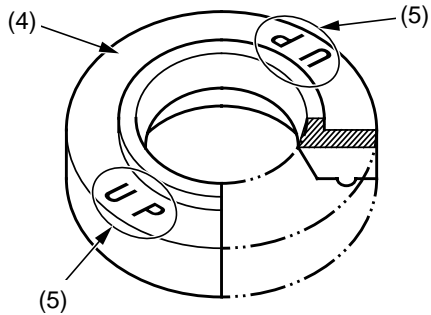

- (4) rubber seal
(5) “UP” marks

4. Install and tighten the cylinder head cover socket bolts (6) to the specified torque:
7 lbf-ft (10 N·m, 1.0 kgf·m)

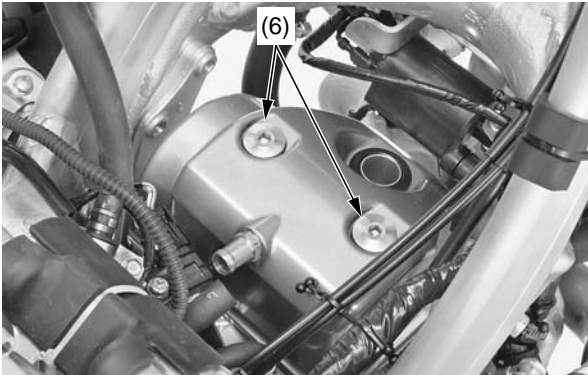

- (6) cylinder head cover socket bolts

5. Connect the spark plug cap (7) and breather tube (8).

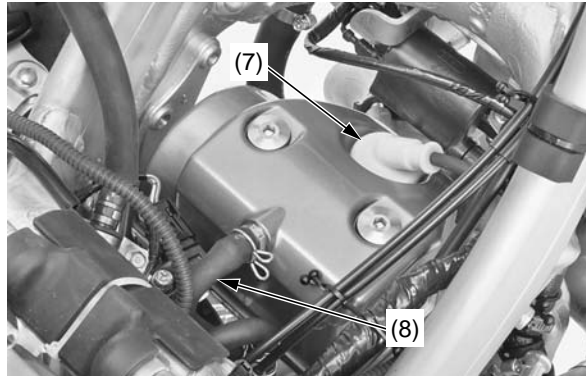

- (7) spark plug cap
(8) breather tube

6. Install the fuel tank and seat (pages 33, 35).

Cylinder Head Removal

1. Clean the area above the engine before disassembly to prevent dirt falling into the engine.
2. Drain the radiator coolant after cooling the motorcycle (page 139).
3. Remove the seat and hang the fuel tank (pages 33, 34).
4. Remove the muffler (page 97) and subframe (page 36).
5. Remove the exhaust pipe (page 99).
6. Remove the spark plug (page 63).
7. Remove the cylinder head cover (page 64).
8. Set the piston at TDC on the compression stroke (page 64).
9. Remove the camshaft holder, camshaft, valve lifters and shims (page 66).

10. Disconnect the ignition coil connectors (1) and unclamp them from the clamp (2). Remove the bolt and washer (3).

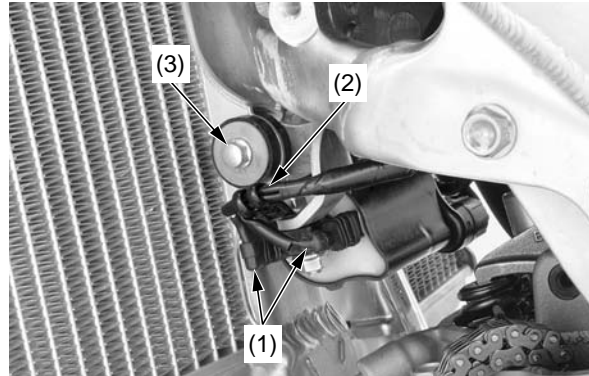

(1) ignition coil connectors (2) clamp
(3) bolt and washer

11. Remove the bolt (4), ground wire (5) and ignition coil/stay (6).

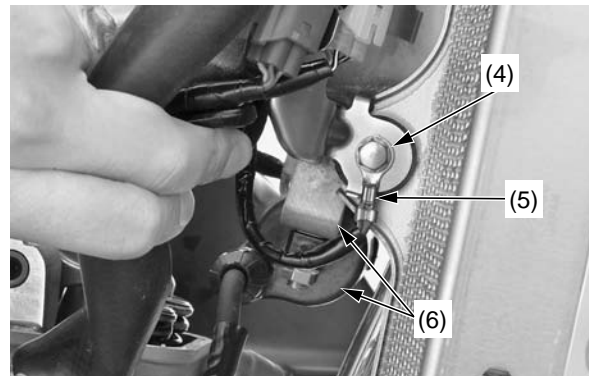

(4) bolt (5) ground wire
(6) ignition coil/stay

12. Disconnect the ECT sensor connector (7).

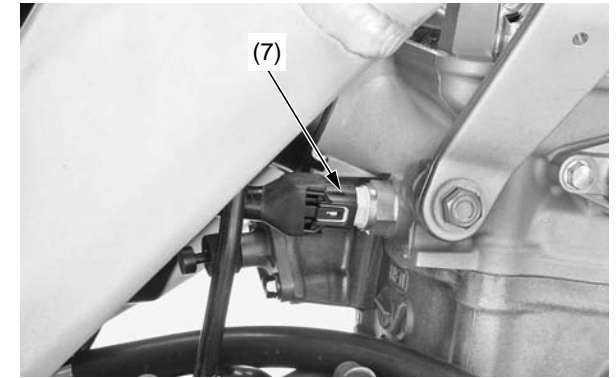

(7) ECT sensor connector

13. Loosen the radiator hose clamp screw (8) and disconnect the radiator hose (9).

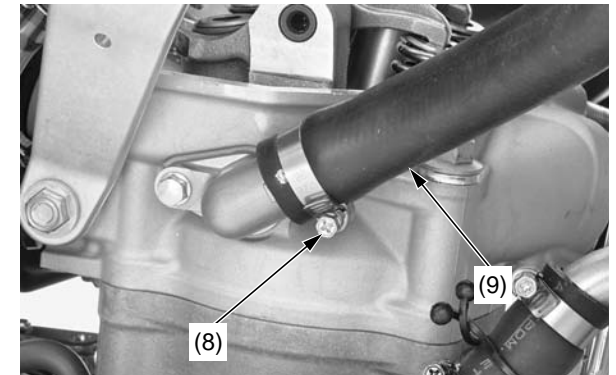

(8) radiator hose clamp screw
(9) radiator hose

(cont'd)

Piston/Piston Rings/Piston Pin

14. Remove the rear shock absorber upper nut (10) and bolt (11).

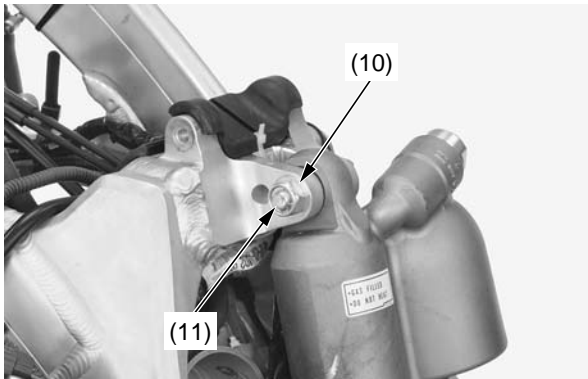

(10) rear shock absorber upper nut
(11) bolt

15. Loosen the insulator band screw (12) and pull the throttle body (13) out from the insulator (14).

Do not hang the throttle body and support it with a suitable strap.

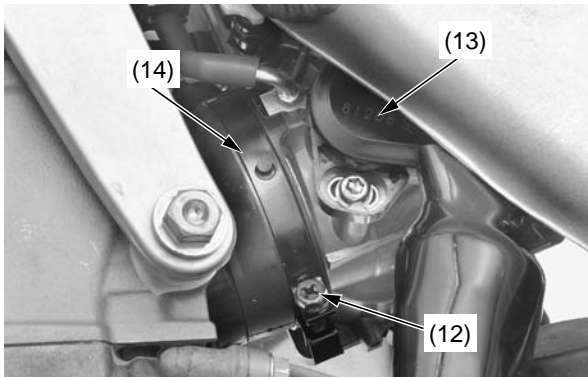

(12) insulator band screw
(13) throttle body
(14) insulator

16. Remove the cylinder head hanger bolts (15). Remove the cylinder head hanger plate bolts (16), left cylinder head hanger plate (17) and right cylinder head hanger plate (18).

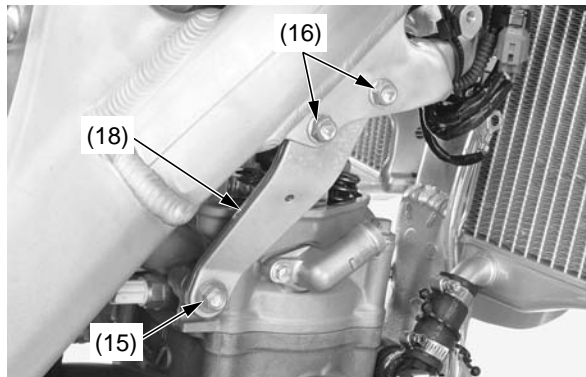
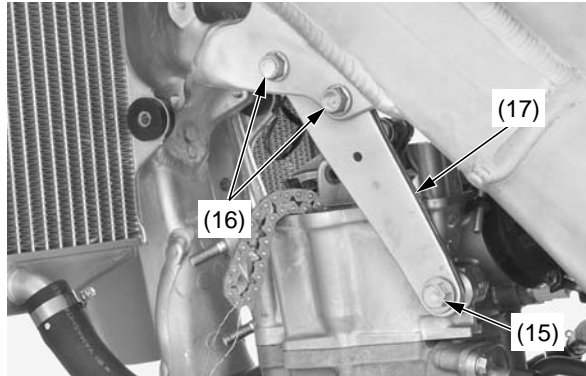

(15) cylinder head hanger bolts
(16) cylinder head hanger plate bolts
(17) left cylinder head hanger plate
(18) right cylinder head hanger plate

17. Remove the cylinder bolt (19).
18. Remove the cylinder head bolts, washers (20) and the cylinder head (21).

Loosen the bolts in a criss-cross pattern in two or three steps.

NOTICE

Do not let the washers and cam chain fall into the crankcase.

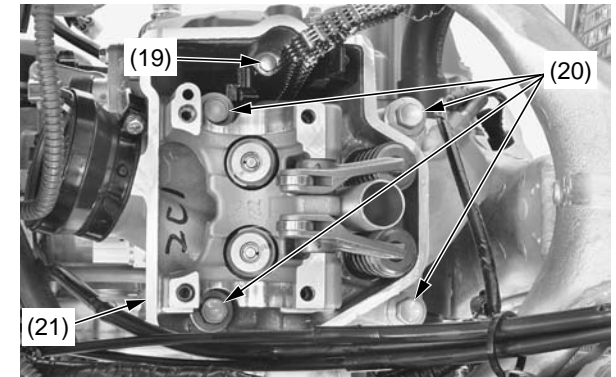

(19) cylinder bolt
(20) cylinder head bolts and washers
(21) cylinder head

19. Remove the dowel pins (22) and cylinder head gasket (23).

NOTICE

Do not let the dowel pins and cam chain fall into the crankcase.

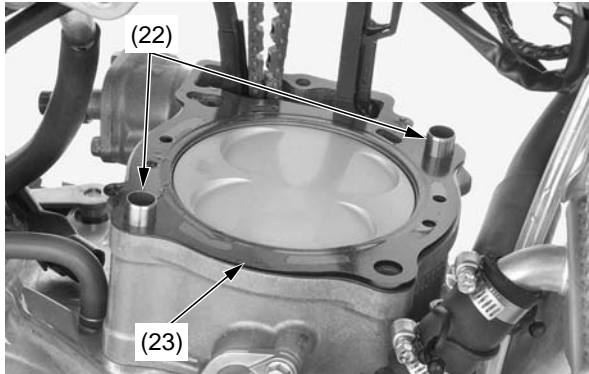

(22) dowel pins
(23) cylinder head gasket

20. Remove the cam chain guide (24) from the cylinder (25).

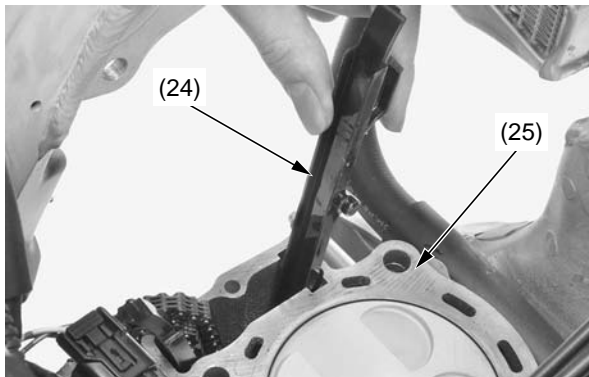

(24) cam chain guide
(25) cylinder

Cylinder Removal

1. Remove the water hose joint bolts (1), water hose joint (2) and O-ring (3).

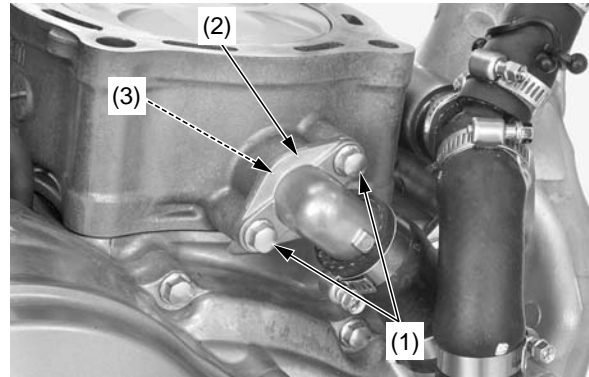

(1) water hose joint bolts (3) O-ring
(2) water hose joint

2. Remove the cylinder (4) while holding the piston (5).

NOTICE

*Do not let the cam chain fall into the crankcase.
Do not pry on or strike the cylinder.*

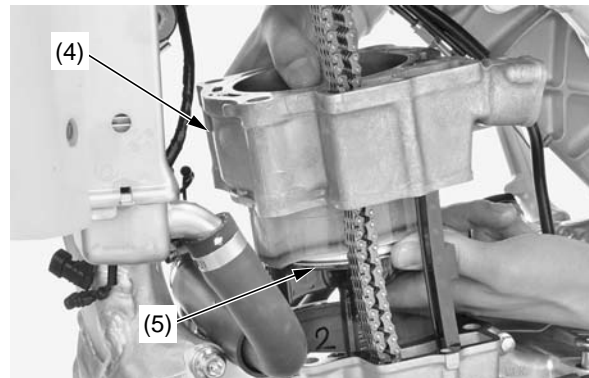

(4) cylinder (5) piston

3. Remove the dowel pins (6) and cylinder gasket (7).

NOTICE

Do not let the dowel pins fall into the crankcase.

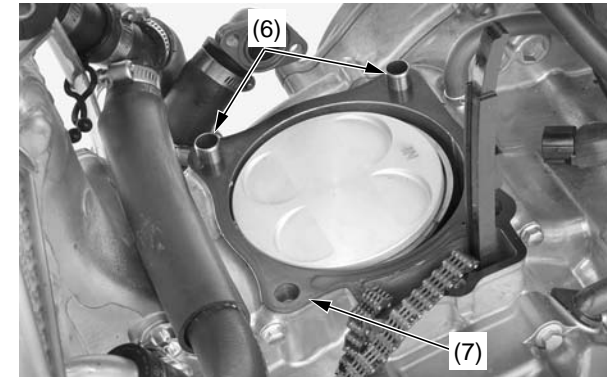

(6) dowel pins (7) cylinder gasket

Piston/Piston Rings/Piston Pin

Piston Removal

1. Place clean shop towels in the crankcase to keep the piston pin clips, or other parts, from falling into the crankcase.
2. Remove the piston pin clips (1) using a pair of needle-nose pliers.
3. Press the piston pin (2) out of the piston (3), and remove the piston.

Under racing conditions, the piston and rings should be replaced every 6 races or about every 15.0 hours of running. Replace the piston pin every 12 races or about every 30.0 hours of running.

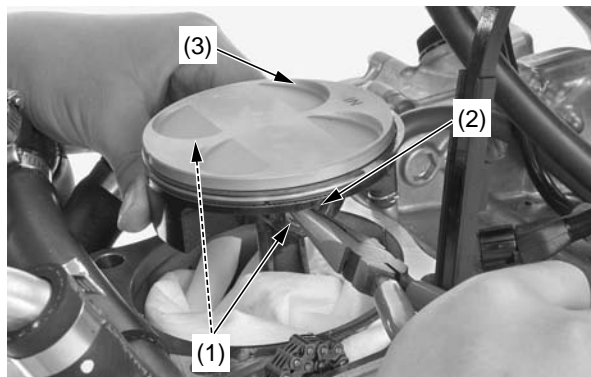

(1) piston pin clips
(2) piston pin

(3) piston

Piston Ring Removal

Spread each piston ring (1) and remove by lifting it up at a point just opposite the gap.

NOTICE

Do not damage the piston ring by spreading the ends too far.

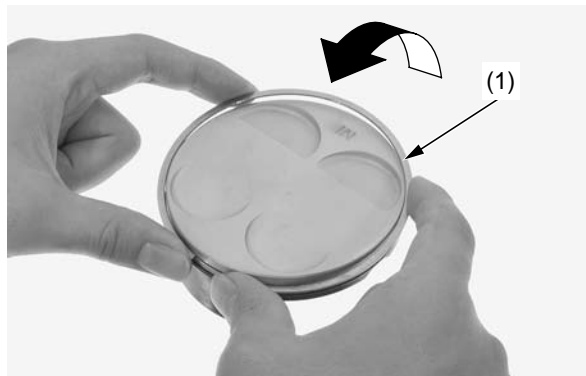

(1) piston ring

Piston/Piston Pin/Piston Ring Inspection

We recommend you consult an official Honda Service Manual or your Honda dealer for correct Service Limit measurements.

Piston Ring Installation

1. Remove the carbon deposits from the piston head and piston ring grooves with the removed piston ring (1).



(1) removed piston ring

2. Apply engine oil to each piston ring whole surface.
3. Install the spacer (2) first, then install the side rails (3) to the piston (4).
4. Install the top ring (5) to the piston with "R" mark (6) side facing up.

NOTICE

*Do not damage the piston ring by spreading the ends too far.
Do not damage the piston during piston ring installation.*

5. After installing the piston rings they should rotate freely, without sticking.
Space the ring end gaps 180 degrees apart between top ring and upper side rail.
Space the ring end gaps 90 degrees apart between upper side rail, spacer and lower side rail.

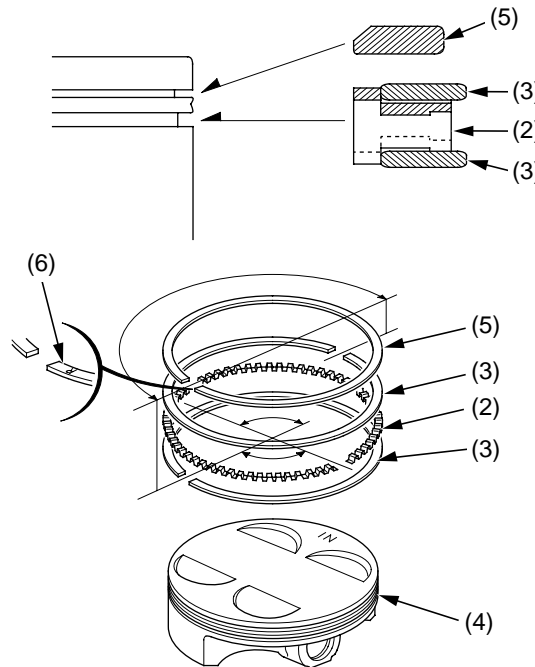

(2) spacer
(3) side rails
(4) piston

(5) top ring
(6) "R" mark

Piston Installation

1. Place clean shop towels (1) over the crankcase opening to keep the piston pin clips from falling into the crankcase.
2. Apply molybdenum disulfide oil (a mixture of 1/2 engine oil and 1/2 molybdenum disulfide grease containing more than 3% molybdenum disulfide additive) to the connecting rod small end (2) inner surface.

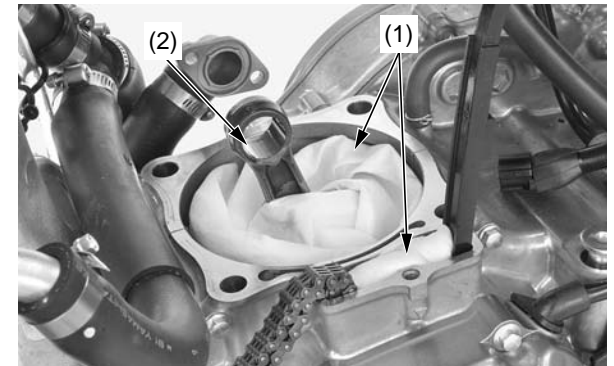

(1) shop towels
(2) connecting rod small end

(cont'd)

Piston/Piston Rings/Piston Pin

3. Install the piston (3) with the "IN" mark (4) and/or the large valve recesses (5) facing the intake side of the engine.

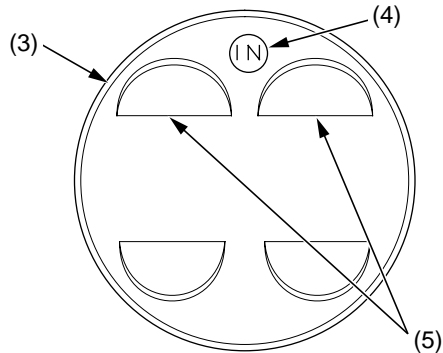

- (3) piston
(4) "IN" mark
(5) large valve recesses

4. Apply engine oil to the piston pin (6) outer surface.
Apply engine oil to the piston outer surface and piston pin hole inner surface.
Install the piston pin and new piston pin clips (7).

NOTICE

*Use new pin clips. Never reuse old clips.
Do not let the clips fall into the crankcase.
Do not align the piston pin clip end gap with the piston cutout (8).*

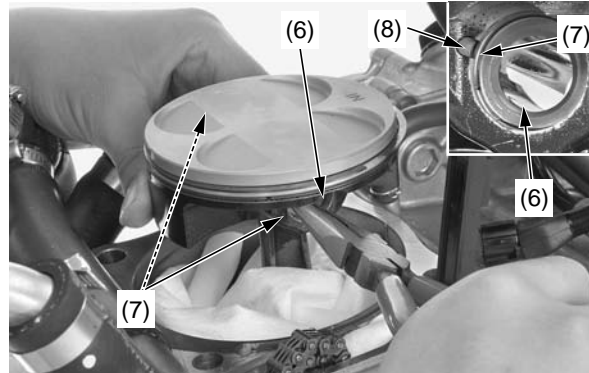

- (6) piston pin
(7) piston pin clips
(8) piston cutout

Cylinder Installation

1. Clean off any gasket material from the gasket surface of the crankcase, being careful not to let any material fall into the crankcase.
Be careful not to remove any metal from the gasket surface.
2. Remove the shop towels. Do not let any gasket debris fall into the crankcase.
3. Install a new cylinder gasket (1) and dowel pins (2).

NOTICE

Do not let the dowel pins fall into the crankcase.

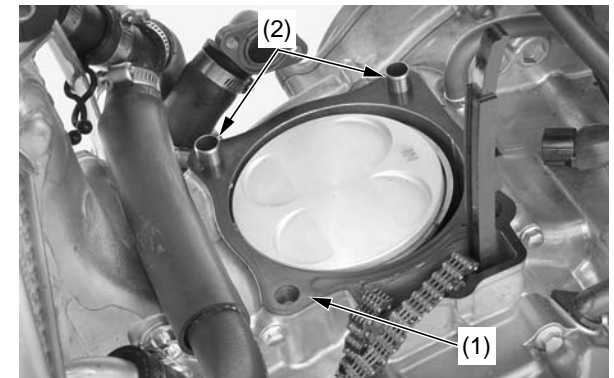

- (1) cylinder gasket
(2) dowel pins

4. Clean any gasket material off cylinder (3).
5. Apply engine oil to the cylinder wall, piston outer surface and piston rings (4).
Route the cam chain (5) through the cylinder. Install the cylinder over the piston rings by hand while compressing the piston rings.

NOTICE

Do not damage the piston rings and cylinder walls.

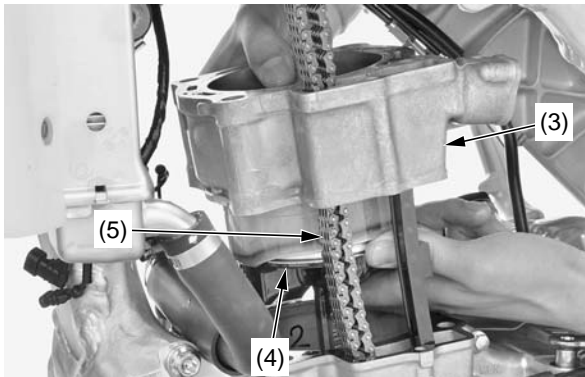

(3) cylinder
(4) piston rings
(5) cam chain

6. Install a new O-ring (6) to the water hose joint (7).
Install the water hose joint and bolts (8), and tighten them to the specified torque:
7 lbf-ft (10 N-m, 1.0 kgf-m)

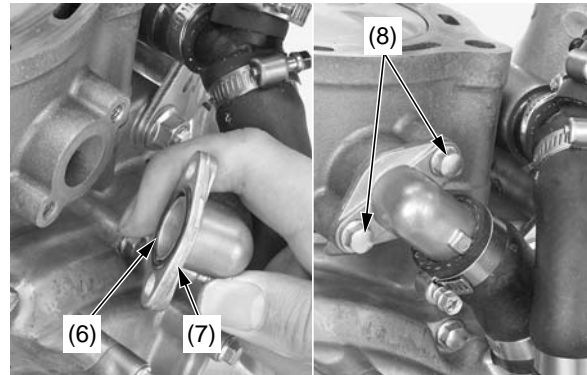

(6) O-ring (new)
(7) water hose joint
(8) bolts

Cylinder Head Installation

1. Install the cam chain guide (1) and fit the cam chain guide tabs (2) in the cylinder cutouts (3). Push the guide until it bottoms in the crankcase guide groove.

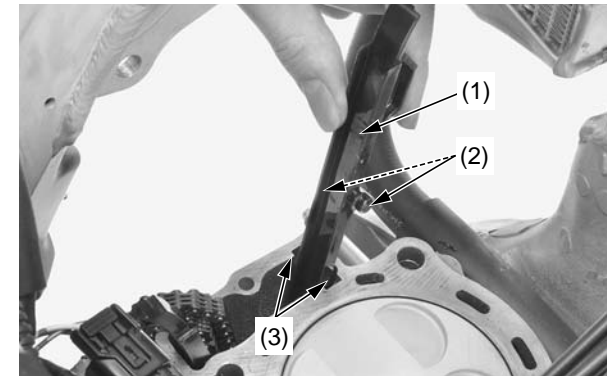

(1) cam chain guide
(2) cam chain guide tabs
(3) cylinder cutouts

2. Install the dowel pins (4) and a new cylinder head gasket (5).

NOTICE

Do not let the dowel pins fall into the crankcase.

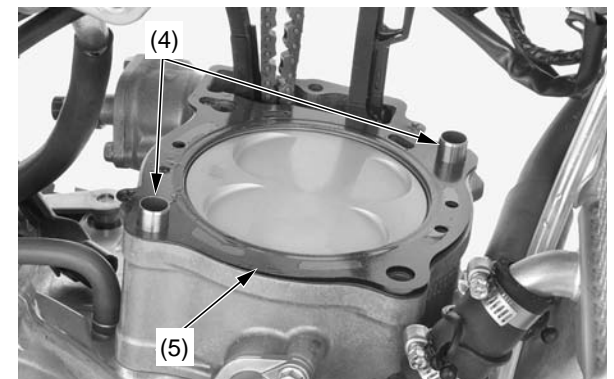

(4) dowel pins
(5) cylinder head gasket

(cont'd)

Piston/Piston Rings/Piston Pin

- Route the cam chain through the cylinder head and install the cylinder head (6).

NOTICE

Do not damage mating surfaces when installing the cylinder head.

- Apply engine oil to all cylinder head bolt threads and seating surface.
Install the washers and cylinder head bolts (7) and tighten them to the specified torque in a crisscross pattern in two or three steps:
38 lbf-ft (51 N·m, 5.2 kgf·m)

NOTICE

Do not let the washers fall into the crankcase.

- Install the cylinder bolt (8) and tighten it to the specified torque:
7 lbf-ft (10 N·m, 1.0 kgf·m)

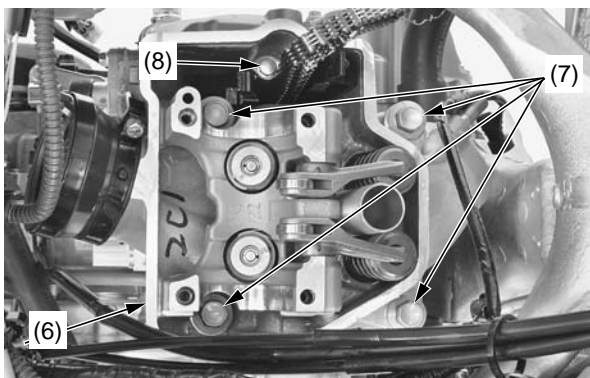

- (6) cylinder head
- (7) washers and cylinder head bolts
- (8) cylinder bolt

- Install the left cylinder head hanger plate (9) and right cylinder head hanger plate (10), then loosely install the cylinder head hanger plate bolts (11) and cylinder head hanger bolts (12). Tighten the cylinder head hanger bolts and cylinder head hanger plate bolts to the specified torque:

- cylinder head hanger bolts:
40 lbf-ft (54 N·m, 5.5 kgf·m)
- cylinder head hanger plate bolts:
24 lbf-ft (33 N·m, 3.4 kgf·m)

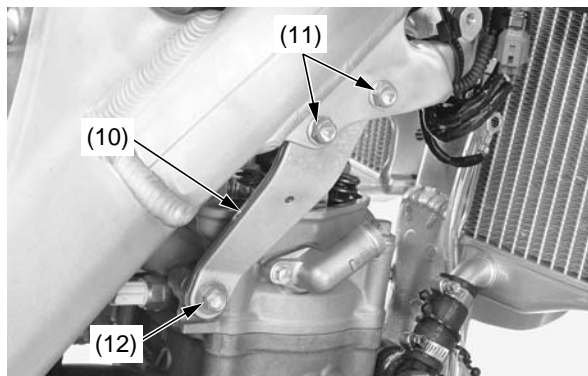
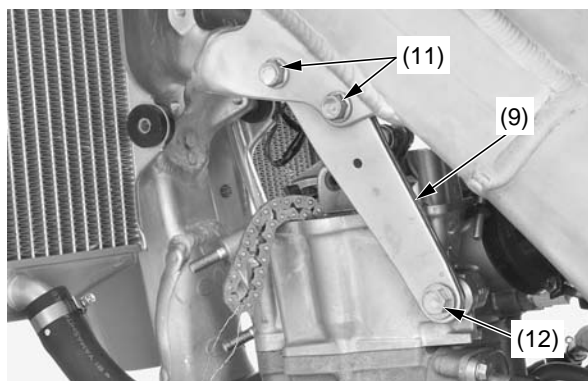

- (9) left cylinder head hanger plate
- (10) right cylinder head hanger plate
- (11) cylinder head hanger plate bolts
- (12) cylinder head hanger bolts

- Install the throttle body (13) to the insulator (14) by aligning the tab of the throttle body with the groove of the insulator and tighten the insulator band screw (15) so the distance between the band ends is 0.47 ± 0.04 in (12.0 ± 1.0 mm).

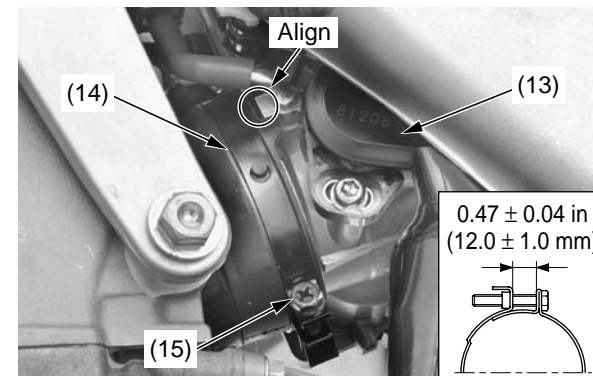

- (13) throttle body
- (14) insulator

- (15) insulator band screw

8. Set the rear shock absorber (16) and install the rear shock absorber upper bolt (17) and nut (18) as shown.
Tighten the rear shock absorber upper nut to the specified torque:
32 lbf-ft (44 N·m, 4.5 kgf·m)

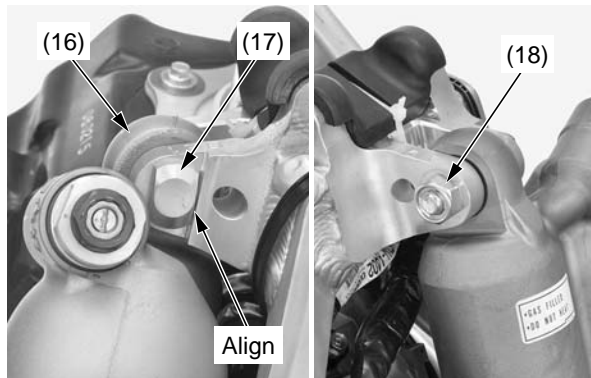

(16) rear shock absorber
(17) rear shock absorber upper bolt
(18) nut

9. Connect the radiator hose (19) to the water hose joint (20) of the cylinder head.

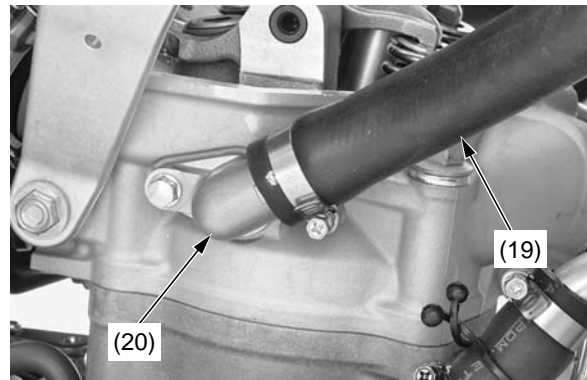

(19) radiator hose
(20) water hose joint

10. Tighten the radiator hose clamp screw (21) as illustrated below.

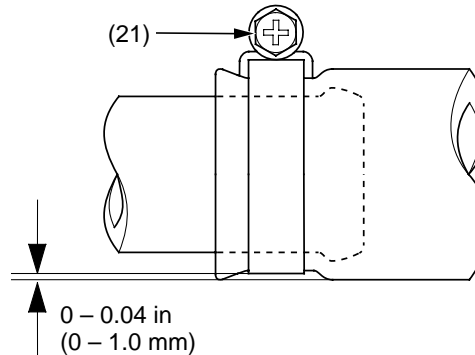

(21) radiator hose clamp screw

11. Connect the ECT sensor connector (22).

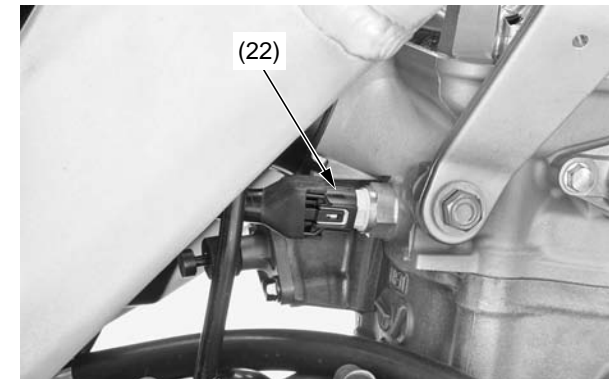

(22) ECT sensor connector

12. Install the ignition coil/stay (23), ground wire (24) and bolt (25).

Push the ground wire against the ignition coil/stay.
Push the ignition coil/stay against the frame.

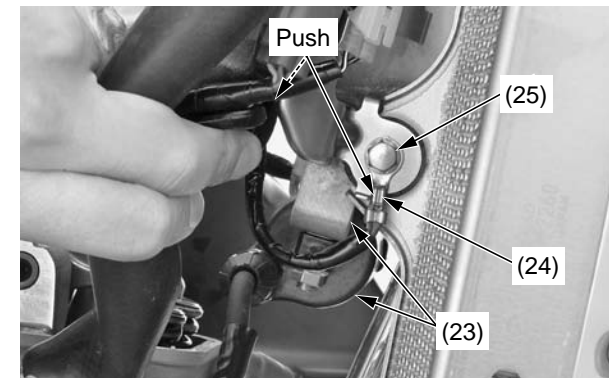

(23) ignition coil/stay
(24) ground wire
(25) bolt

(cont'd)

Piston/Piston Rings/Piston Pin

13. Install the ignition coil/stay (23), washer (26) and bolt (27).
Set the clamp facing rearward and tighten the bolts (25) (27).
14. Clamp the ignition coil connector wires to the clamp (28) and connect the ignition coil connectors (29).

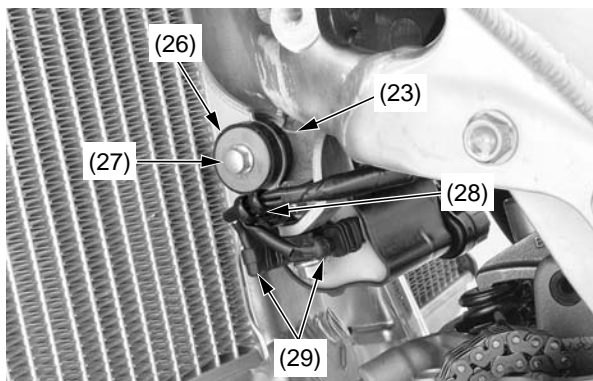

- (23) ignition coil/stay
(26) washer
(27) bolt
(28) clamp
(29) ignition coil connectors

15. Install the shims, valve lifters, camshaft and camshaft holder (page 69).
16. Install the crankshaft hole cap (page 71).
17. Install the cylinder head cover (page 71).
18. Install the spark plug (page 63).
19. Install the exhaust pipe (page 99).
20. Install the subframe (page 35) and muffler (page 98).
21. Install the fuel tank and seat (pages 33, 35).

22. Fill and bleed the cooling system (page 139).
Check for the following:
 - compression leaks
 - abnormal engine noise
 - secondary air leaks
 - coolant leaks
 - oil leaks

Refer to *Safety Precautions* on page 23.

Loose, worn, or damaged suspension components may adversely affect the handling and stability of your CRF. If any suspension components appear worn or damaged, see your Honda dealer for further inspection. Your dealer is qualified to determine whether or not replacement parts or repairs are needed.

Front Suspension Inspection

- When your CRF is new, break it in for approximately 1 hour to ensure that the suspension has worked in (page 19).
- After break-in, test run your CRF with the front suspension at the standard setting before attempting any adjustments.
- For optimum fork performance, we recommend that you disassemble and clean the fork after riding your CRF for 3 hours. See page 110 for fork disassembly.
- Replace the fork oil every 3 races or 7.5 hours of running. See page 85 for oil capacity adjustment after changing the fork oil.
- Replace the damper oil every 9 races or 22.5 hours of running. See page 113 for damper fork oil replacement.
- Use KHL15-11 (KYB) which contains special additives to assure maximum performance of your CRF's front suspension.
- Periodically check and clean all front suspension parts to assure top performance. Check the dust seals for dust, dirt, and foreign materials. Check the oil for any contamination.

- Refer to *Suspension Adjustment Guidelines* (page 127). Make all rebound and compression damping adjustments in one-click increments. (Adjusting two or more clicks at a time may cause you to pass over the best adjustment.) Test ride after each adjustment.
- If you become confused about adjustment settings, return to the standard position and start over.
- If the fork is still too stiff/soft after adjusting compression damping, determine which portion of the travel is still too stiff/soft. This is an important step that will help you solve suspension problems.

1. Make sure that the fork protectors (1) and dust seals (2) are clean and not packed with mud and dirt.
2. Check for signs of oil leakage. Damaged or leaking fork seals should be replaced before your CRF is ridden.

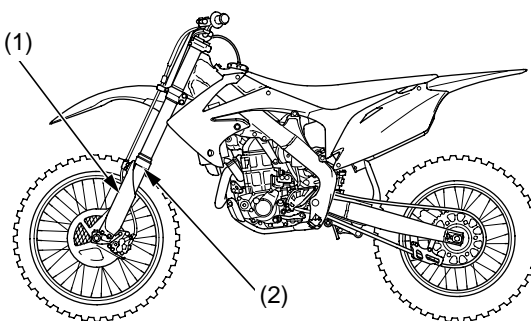

(1) fork protector

(2) dust seal

3. Inspect the wear rings (3) for wear or damage. Replace the wear ring if it is 0.06 in (1.5 mm) or flat with the outer tube (4). Remove the fork leg when replacing the wear ring. Install the wear ring with its end gap (5) facing rearward.

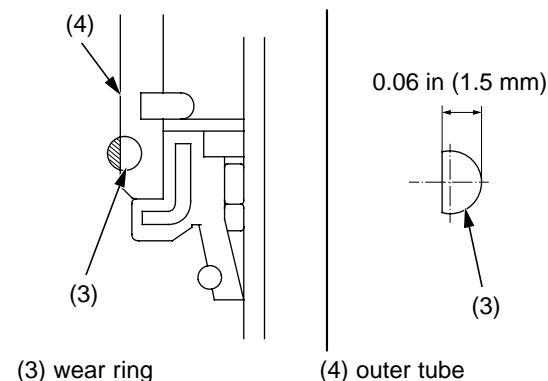

(3) wear ring

(4) outer tube

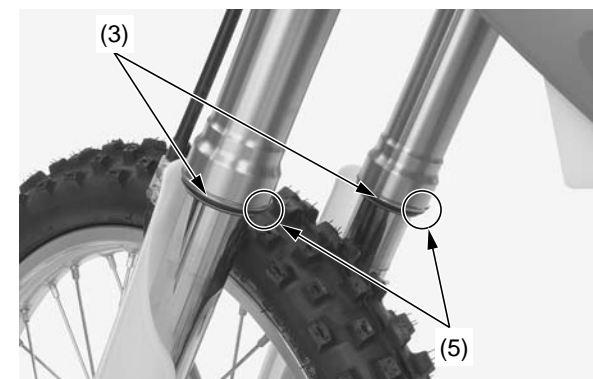

(3) wear rings

(5) end gaps

4. Make a quick check of fork operation by locking the front brake and pushing down on the handlebar several times.



Suspension

Rear Suspension Inspection

The swingarm is controlled by one hydraulic shock absorber with an aluminum reservoir for oil and nitrogen gas pressure. The gas pressure in the reservoir is contained within a rubber bladder.

The rear suspension's spring pre-load and damping adjustments (compression and rebound) should be adjusted for the rider's weight and track conditions (pages 124, 129).

Do not attempt to disassemble, service, or dispose of the damper; see your Honda dealer. The instructions found in this owner's manual are limited to adjustments of the shock assembly only.

- When your CRF is new, break it in for approximately 1 hour with the standard suspension settings before attempting to adjust the rear suspension.
- Refer to *Suspension Adjustment Information* (page 129) for making all rebound and compression damping adjustments in one click or 1/12 turn increments (Adjusting two or more clicks or turns at a time may cause you to pass over the best adjustment.) Test ride after each adjustment.
- If the rear suspension is too stiff/soft, adjust it by turning all the compression and rebound adjusters according to the procedures described in page 123. After adjusting the adjusters simultaneously, suspension may be fine-tuned by turning one of the compression and rebound damping adjusters in one click or in 1/12 turn increments.
- If you have a problem finding an acceptable adjustment, return to the standard position and begin again.

1. Bounce the rear of the motorcycle up and down and check for smooth suspension action.



2. Remove the muffler (page 97) and subframe (page 36).
3. Check for a broken or collapsed spring.
4. Check the rear shock absorber (1) for a bent rod or oil leaks.

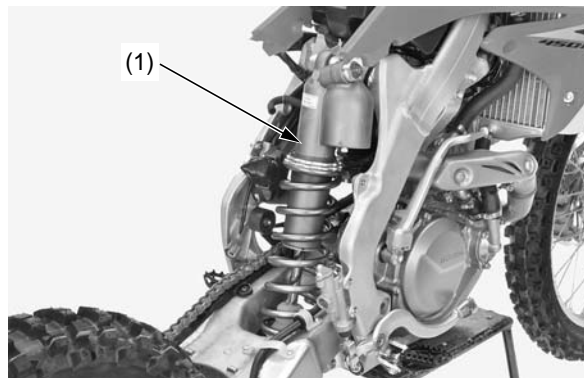

(1) rear shock absorber

5. Push the rear wheel sideways to check for worn or loose swingarm bearings. There should be no movement. If there is, have the bearings replaced by your Honda dealer.

Recommended Fork Oil

suggested oil	KHL15-11 (KYB)
---------------	----------------

Fork Oil Change

Refer to *Front Suspension Disassembly* on page 110 for front suspension removal.

1. Clean the fork assembly, especially the sliding surface of the slider and dust seal.
 2. Hold the outer tube (1), then remove the fork damper (2) from the outer tube using the lock nut wrench (3). Gently slide the outer tube down onto the lower end of the slider (4).
- Lock nut wrench 070MA-MEN0100

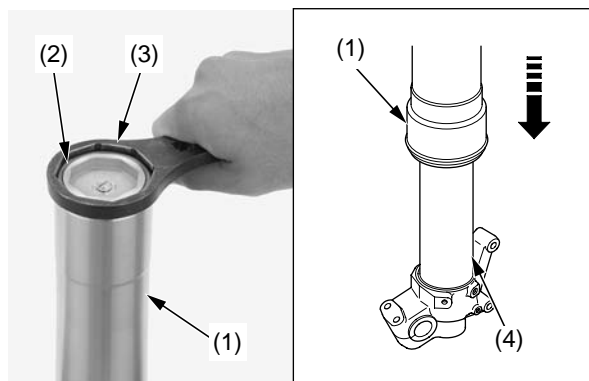

(1) outer tube
(2) fork damper

(3) lock nut wrench
(4) slider

NOTICE

The outer tube (1) can drop on the slider (5) and damage the fork dust seal (6). To avoid damage, hold both the outer tube and slider when removing the fork damper.

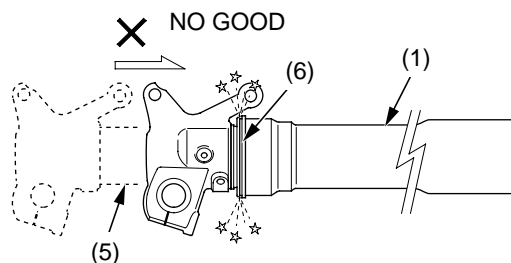

(1) outer tube
(5) slider

(6) fork dust seal

3. Drain the fork oil from the outer tube (1). Drain the fork oil from the oil holes (7) of the fork damper.

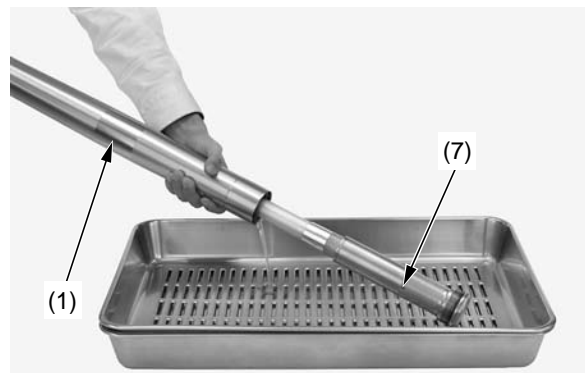

(1) outer tube

(7) oil holes

4. Drain the fork oil by turning the outer tube (1) upside down. (About 0.5 US oz (15.8 cm³) of fork oil will be left in the outer tube when it is left inverted for about 20 minutes at 68°F/20°C.)

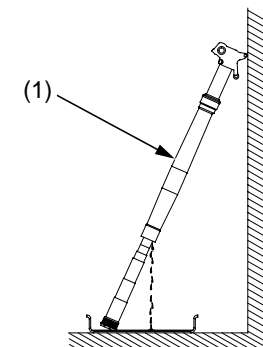

(1) outer tube

Pour the drained oil into a suitable container and dispose of it in an approved manner (page 140).

NOTICE

Improper disposal of drained oil is harmful to the environment.

Amount of fork oil left in the fork (within damper and spring)

unit: cm³

minute °F/°C	5	10	20	35	55	85	145
32/0	24.6	22.0	19.4	17.7	16.5	15.5	14.0
50/10	22.7	19.8	17.6	16.0	14.8	13.9	12.4
68/20	21.5	18.1	15.8	14.0	13.1	12.0	10.8
86/30	20.5	16.8	14.9	13.1	11.8	11.0	9.7

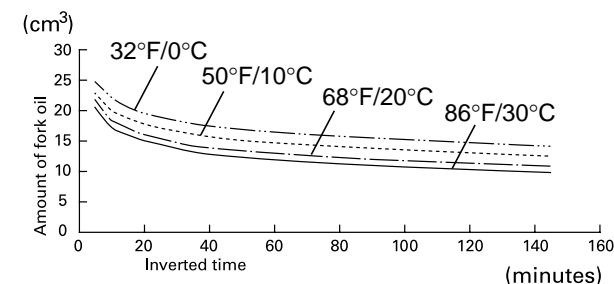

(cont'd)

Suspension

5. Pour the recommended fork oil (page 85) into the outer tube.

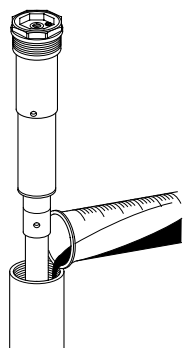

Fork Oil Capacity:

Standard 26.27 lbf/in (4.6 N/mm) Fork Spring

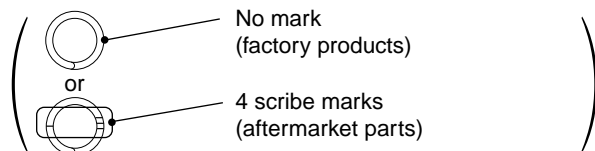

Standard oil capacity	12.0 US oz (355 cm ³)	
Maximum oil capacity	12.2 US oz (362 cm ³)	Slightly stiffer as it nears full compression.
Minimum oil capacity	10.3 US oz (305 cm ³)	Slightly softer as it nears full compression.

Optional Softer 25.12 lbf/in (4.4 N/mm) Fork Spring

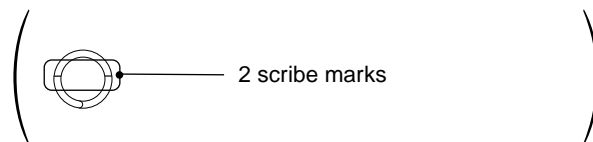

Standard oil capacity	11.9 US oz (352 cm ³)	
Maximum oil capacity	12.1 US oz (359 cm ³)	Slightly stiffer as it nears full compression.
Minimum oil capacity	10.2 US oz (303 cm ³)	Slightly softer as it nears full compression.

Optional Stiffer 27.41 lbf/in (4.8 N/mm) Fork Spring

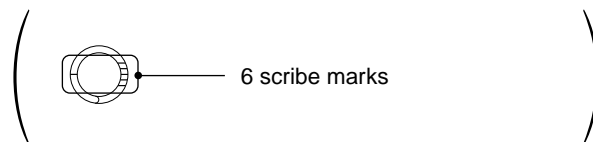

Standard oil capacity	11.8 US oz (350 cm ³)	
Maximum oil capacity	12.1 US oz (357 cm ³)	Slightly stiffer as it nears full compression.
Minimum oil capacity	10.1 US oz (300 cm ³)	Slightly softer as it nears full compression.

Be sure the oil capacity is the same in both fork legs.

6. Check that the O-ring (8) on the fork damper (2) is in good condition. Apply the recommended fork oil to the O-ring. Temporarily install the fork damper to the outer tube (1). After installing the fork leg (page 110), tighten the fork damper to the specified torque using the lock nut wrench:
Actual:
22 lbf·ft (30 N·m, 3.1 kgf·m)
Torque wrench scale reading:
20 lbf·ft (27 N·m, 2.8 kgf·m), using a 20 in (50 cm) long deflecting beam type torque wrench.

When using the lock nut wrench, use a 20 in (50 cm) long deflecting beam type torque wrench with a lock nut wrench. The lock nut wrench increases the torque wrench's leverage, so the torque wrench reading will be less than the torque actually applied to the fork damper.

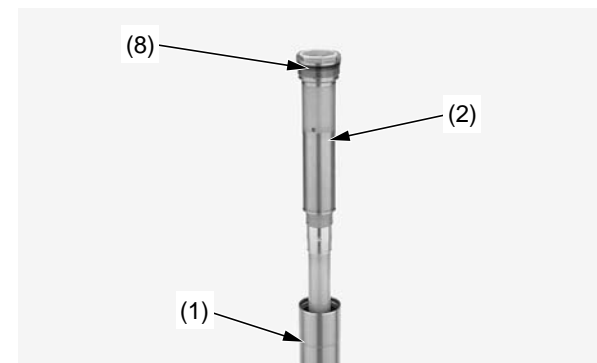

- (1) outer tube
- (2) fork damper
- (8) O-ring

Refer to *Safety Precautions* on page 23.

Both the front and rear brakes are the hydraulic disc type. As the brake pads wear, the brake fluid level will drop. A leak in the system will also cause the level to drop.

Frequently inspect the system to ensure there are no fluid leaks. Periodically inspect the brake fluid level and the brake pads for wear.

If the braking response of the front brake lever or rear pedal feels unusual, check the brake pads. If the brake pads are not worn beyond the recommended limit (page 90), there is probably air in the brake system.

Refer to an official Honda Service Manual or see your Honda dealer to have the air bled from the system.

Front Brake Lever Adjustment

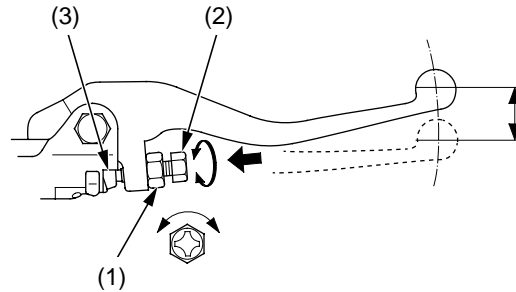

(1) lock nut
(2) adjuster

(3) knocker arm

1. Loosen the lock nut (1).
2. To position the front brake lever farther away from the handgrip, turn the adjuster (2) clockwise.
To position the front brake lever closer to the handgrip, turn the adjuster counterclockwise.
3. While holding the adjuster, tighten the lock nut to the specified torque:
4.4 lbf·ft (5.9 N·m, 0.6 kgf·m)
4. Apply silicone grease to the contacting areas of the adjuster and knocker arm (3).

Rear Brake Pedal Height

The rear brake pedal height should be approximately level with the right footpeg.

1. Loosen the lock nut (1) and turn the push rod (2) in direction (+) to raise the rear brake pedal (3) or in direction (–) to lower it.
2. Tighten the push rod lock nut to the specified torque at the desired pedal height.
4.4 lbf·ft (5.9 N·m, 0.6 kgf·m)

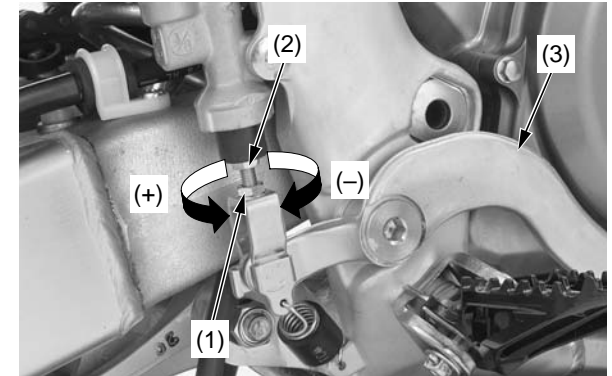

(1) lock nut
(2) push rod
(3) rear brake pedal

(+) raise the pedal height
(–) lower the pedal height

Brakes

Fluid Level Inspection

Front Brake Fluid Level Check

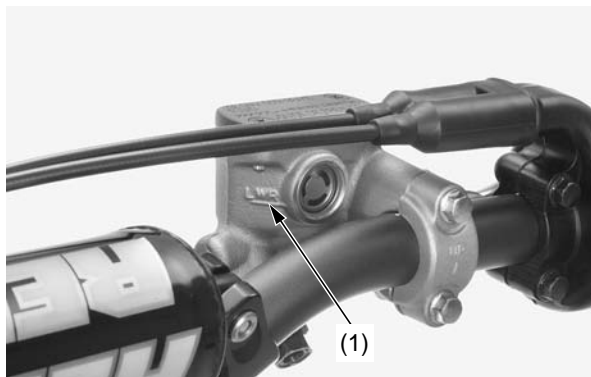

(1) LWR mark

With the motorcycle in an upright position, check the fluid level.

It should be above the LWR mark (1). If the level is at or below the LWR mark, check the brake pads for wear (page 90).

Worn brake pads should be replaced. If the pads are not worn, have your brake system inspected for leaks.

If the pulling distance for the front brake lever feels excessive, there is probably air in the brake system and it must be bled. Refer to an official Honda Service Manual or see your Honda dealer for brake bleeding.

Honda recommends using Pro Honda DOT 4 Brake fluid from a sealed container, or an equivalent.

Other Checks:

Make sure there are no fluid leaks. Check for deterioration or cracks in the hoses and fittings.

Rear Brake Fluid Level Check

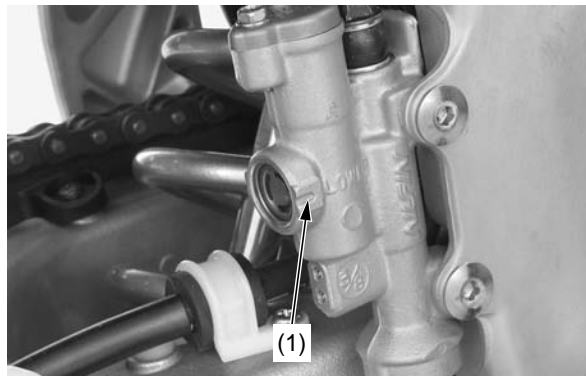

(1) LOWER mark

With the motorcycle in an upright position, check the fluid level.

It should be above the LOWER mark (1). If the level is at or below the LOWER mark, check the brake pads for wear (page 90).

Worn brake pads should be replaced. If the pads are not worn, have your brake system inspected for leaks.

If the travel for the rear brake pedal feels excessive, there is probably air in the brake system and it must be bled. Refer to an official Honda Service Manual or see your Honda dealer for brake bleeding.

Honda recommends using Pro Honda DOT 4 Brake fluid from a sealed container, or an equivalent.

Other Checks:

Make sure there are no fluid leaks. Check for deterioration or cracks in the hoses and fittings.

Adding Front Brake Fluid

NOTICE

Spilled brake fluid will severely damage instrument lenses and painted surfaces. It is also harmful to some rubber parts. Be careful whenever you remove the reservoir cap; make sure the reservoir is horizontal first.

- Always use fresh DOT 4 brake fluid from a sealed container when servicing the system. Do not mix different types of fluid, they may not be compatible.
- The recommended brake fluid is Pro Honda DOT 4 brake fluid or an equivalent.

1. Remove the front brake reservoir cap screws (1), reservoir cap (2) and diaphragm (3).
2. Fill the reservoir with DOT 4 brake fluid to the upper level mark (4). Do not overfill.
3. Install the diaphragm and reservoir cap.
4. Tighten the front brake reservoir cap screws to the specified torque:
0.7 lbf·ft (1.0 N·m, 0.1 kgf·m)

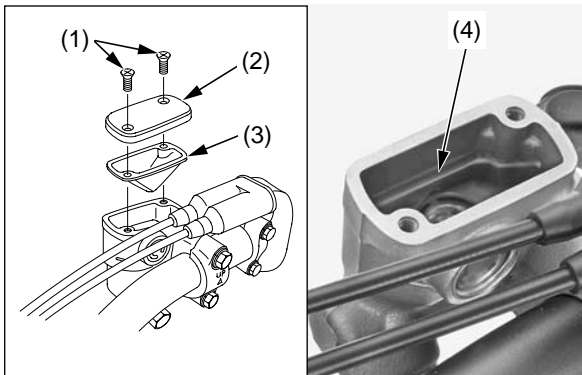

- (1) front brake reservoir cap screws
- (2) reservoir cap
- (3) diaphragm
- (4) upper level mark

Adding Rear Brake Fluid

NOTICE

Spilled brake fluid will severely damage instrument lenses and painted surfaces. It is also harmful to some rubber parts. Be careful whenever you remove the reservoir cap; make sure the reservoir is horizontal first.

- Always use fresh DOT 4 brake fluid from a sealed container when servicing the system. Do not mix different types of fluid, they may not be compatible.
- The recommended brake fluid is Pro Honda DOT 4 brake fluid or an equivalent.

1. Remove the rear brake reservoir cap bolts (1), reservoir cap (2), set plate (3) and diaphragm (4).
2. Fill the reservoir with DOT 4 brake fluid to the upper level mark (5). Do not overfill.

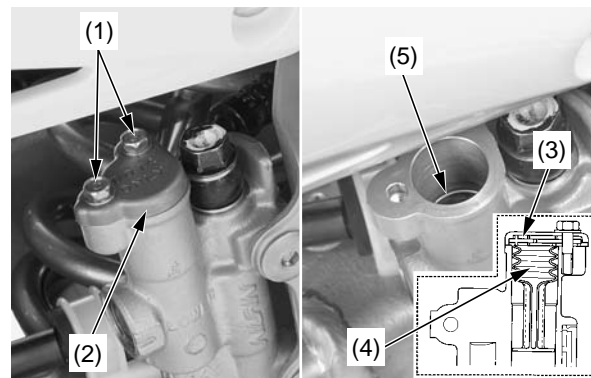

- (1) rear brake reservoir cap bolts
- (2) reservoir cap
- (3) set plate
- (4) diaphragm
- (5) upper level mark

3. Install the diaphragm, set plate and reservoir cap.
4. Tighten the rear brake reservoir cap bolts to the specified torque:
0.7 lbf·ft (1.0 N·m, 0.1 kgf·m)

Brakes

Brake Pad Wear

Brake pad wear depends on the severity of usage and track conditions. (Generally, the pads will wear faster on wet and dirty tracks) Inspect the pads at each regular maintenance interval (page 25).

Front Brake Pads

Inspect the brake pads (1) through the front wheel to determine the brake pad wear. If either brake pad is worn anywhere to a thickness of 0.04 in (1.0 mm), both brake pads must be replaced.

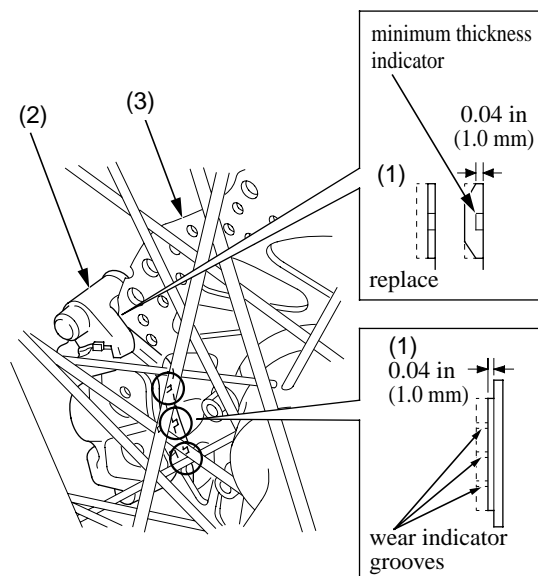

(1) brake pads
(2) front brake caliper

(3) brake disc

Rear Brake Pads

Inspect the brake pads (1) from the rear side of the caliper to determine the brake pad wear. If either brake pad is worn anywhere to a thickness of 0.04 in (1.0 mm), both brake pads must be replaced.

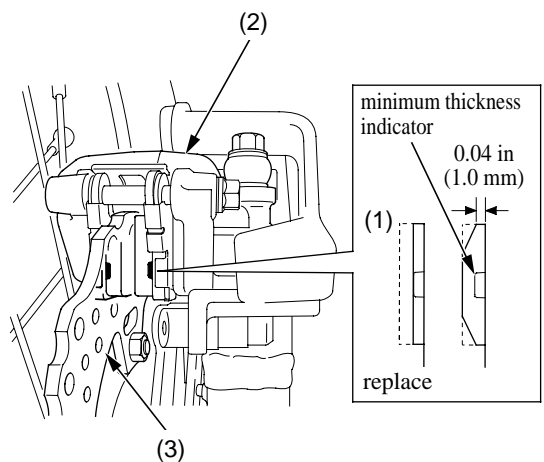

(1) brake pads
(2) rear brake caliper

(3) brake disc

Other Inspections

Check that the front brake lever and rear brake pedal assemblies are positioned properly (page 87) and the securing bolts are tight.

Make sure there are no fluid leaks. Check for deterioration or cracks in the hoses and fittings.

Refer to *Safety Precautions* on page 23.

Keeping the wheels true (round) and maintaining correct spoke tension is critical to safe motorcycle operation. During the first few rides, spokes will loosen more rapidly due to the initial seating of the parts. Excessively loose spokes may result in instability at high speeds and the possible loss of control. It's also important that the rim locks are secure to prevent tire slippage.

It is not necessary to remove the wheels to perform the recommended service in the Maintenance Schedule (page 25). However, information for wheel removal is provided for emergency situations.

Wheel Rims & Spokes

1. Inspect the wheel rims (1) and spokes (2) for damage.
2. Tighten, any loose spokes and rim locks (3) to the specified torque:
Spokes: 2.7 lbf·ft (3.7 N·m, 0.4 kgf·m)
Rim Locks : 9 lbf·ft (12 N·m, 1.2 kgf·m)
3. Check wheel rim runout. If runout is noticeable, see an official Honda Service Manual for inspection instructions.

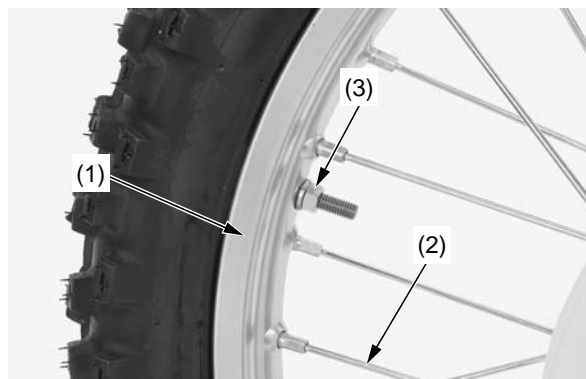

(1) wheel rim
(2) spoke

(3) rim lock

Axles & Wheel Bearings

See an official Honda Service Manual for inspection information:

1. Check the axle shaft for runout.
2. Check the condition of the wheel bearings.

Tires & Tubes

Refer to *Safety Precautions* on page 23.

To safely operate your CRF, the tires must be the proper type (off-road) and size, in good condition with adequate tread, and correctly inflated.

⚠ WARNING

Using tires that are excessively worn or improperly inflated can cause a crash in which you can be seriously hurt or killed.

Follow all instructions in this owner's manual regarding tire inflation and maintenance.

The following pages give detailed information on how and when to check your air pressure, how to inspect your tires for wear and damage, and our recommendations on tire repair and replacement.

Air Pressure

Properly inflated tires provide the best combination of handling, tread life, and riding comfort. Generally, underinflated tires wear unevenly, adversely affect handling, and are more likely to fail from being overheated.

Underinflated tires can also cause wheel damage on hard terrain. Overinflated tires make your CRF ride harshly, are more prone to damage from surface hazards, and wear unevenly.

Make sure the valve stem caps are secure. If necessary, install new caps.

Always check air pressure when your tires are “cold.” If you check air pressure when your tires are “warm” — even if your CRF has only been ridden for a few miles — the readings will be higher. If you let air out of warm tires to match the recommended cold pressures, the tires will be underinflated.

The correct “cold” tire pressures are:

Front	15 psi (100 kPa, 1.0 kgf/cm ²)
Rear	15 psi (100 kPa, 1.0 kgf/cm ²)

If you decide to adjust tire pressures for a particular riding condition, make changes a little at a time.

Inspection

Take time to inspect your tires and wheels before you ride.

- Inspect carefully for bumps or bulges in the side of the tire or the tread. Replace any tire that has a bump or bulge.
- Look closely for cuts, slits, or cracks in the tires. Replace a tire if you can see fabric or cord.
- Check for rocks or other objects embedded in the tire or tread. Remove any objects.
- Check the position of both valve stems. A tilted valve stem indicates the tube is slipping inside the tire or the tire is slipping on the rim.

Tube Replacement

If a tube is punctured or damaged, you should replace it as soon as possible. A repaired tube may not have the same reliability as a new one, and it may fail while you are riding.

Use a replacement tube equivalent to the original.

Tire Replacement

The tires that came on your CRF were designed to provide a good combination of handling, braking, durability, and comfort across a broad range of riding conditions.

⚠ WARNING

Installing improper tires on your motorcycle can affect handling and stability. This can cause a crash in which you can be seriously hurt or killed.

Always use the size and type of tires recommended in this owner's manual.

Front	80/100 – 21 51M	
	DUNLOP	D742FA
Rear	120/80 – 19 63M	
	DUNLOP	D756
Type	bias-ply, tube	

- When replacing, use the original equipment tires or equivalent tires of the same size, construction, speed rating, and load range as the original.
- Replace the tube any time you replace a tire. The old tube will probably be stretched and, if installed in a new tire, could fail.

Drive Chain

Refer to *Safety Precautions* on page 23.

The service life of the chain depends on proper lubrication and adjustment. Poor maintenance can cause premature wear or damage to the drive chain or sprockets.

When the motorcycle is ridden on unusually dusty or muddy tracks, more frequent maintenance will be necessary.

Before servicing your drive chain, turn the engine OFF and check that your transmission is in neutral.

Inspection

1. Turn the engine off, raise the rear wheel off the ground by placing an optional workstand or equivalent support under the engine and shift the transmission into neutral.
2. Check the drive chain slack (1) in the upper drive chain run midway between the drive (2) and driven sprockets (3). Drive chain slack should allow the following vertical movement by hand:
1 3/16 – 1 9/16 in (30 – 40 mm)

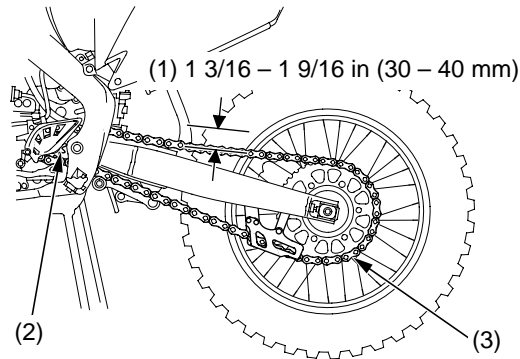

- (1) drive chain slack
(2) drive sprocket
(3) driven sprocket

3. Check drive chain slack at several points along the chain. The slack should remain constant. If it isn't, some links may be kinked and binding. Lubricating the chain will often eliminate binding and kinking.

NOTICE

Excessive chain slack may allow the drive chain to damage the engine cases.

4. Inspect the drive chain for:
 - damaged rollers
 - loose pins
 - dry or rusted links
 - kinked or binding links
 - excessive wear

Replace the drive chain (page 96) if it has damaged rollers, loose pins, or kinks that cannot be free. Lubricate the drive chain (page 95) if it appears dry or shows signs of rust. Lubricate any kinked or binding links and work them free. Adjust chain slack if needed (page 95).

Drive Chain Sliders

1. Check the chain slider (1) for wear. Replace it if below the service limit.
SERVICE LIMIT:
upper side: 0.2 in (5 mm)
lower side: 0.10 in (2.5 mm)

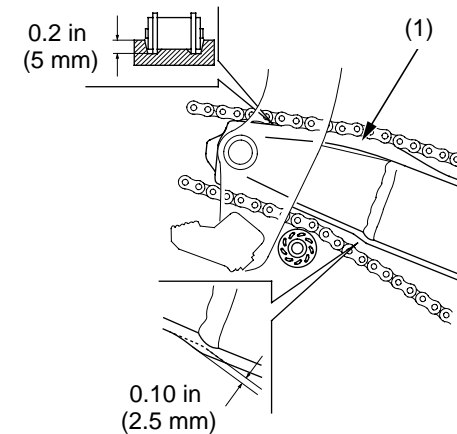

- (1) chain slider

2. Check the chain guide slider (2) for wear. Replace the guide slider if it is worn to the bottom of the wear limit (3).

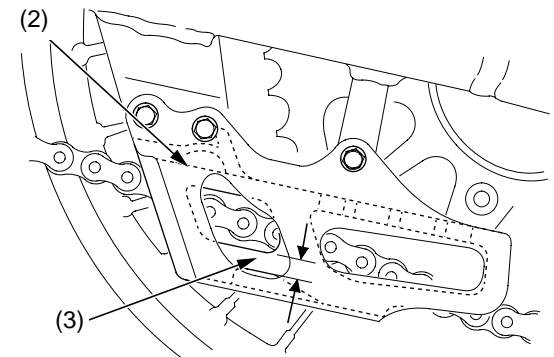

- (2) chain guide slider
(3) wear limit

Drive Chain Rollers

Measure the diameter of the upper (1) and lower drive chain rollers (2). Remove them if below the service limit.

SERVICE LIMIT: 1.4 in (35 mm)

Replace the roller if beyond the service limit. Install the upper drive chain roller (Green) with the “→” mark (3) facing toward the frame and lower drive chain roller (Black) with the “→” mark (3) side facing out.

Install the drive chain roller bolt and nut.

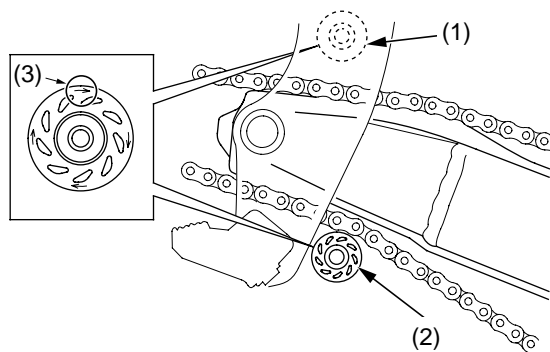

- (1) upper drive chain roller (Green)
- (2) lower drive chain roller (Black)
- (3) “→” mark

Tighten the drive chain roller bolt and nut to the specified torque:

9 lbf·ft (12 N·m, 1.2 kgf·m)

Adjustment

1. Loosen the rear axle nut (1).
2. Loosen the chain adjuster lock nuts (2) and turn the adjusting bolts (3) counterclockwise to decrease slack or clockwise to increase slack.

Align the index marks (4) of the axle plates (5) with the same reference marks (6) on both sides of the swingarm.

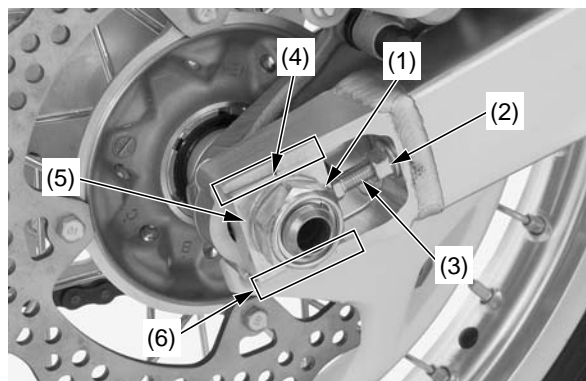

- (1) rear axle nut
- (2) chain adjuster lock nuts
- (3) adjusting bolts
- (4) index marks
- (5) axle plates
- (6) reference marks

3. Tighten the rear axle nut to the specified torque:
94 lbf·ft (128 N·m, 13.1 kgf·m)
4. Recheck chain slack and adjust as necessary.
5. Turn the adjusting bolt counterclockwise until it touches the axle plates lightly. Then tighten the chain adjuster lock nuts to the specified torque while holding the adjusting bolts with a wrench:
20 lbf·ft (27 N·m, 2.8 kgf·m)

Lubrication

Commercially prepared drive chain lubricants may be purchased at most motorcycle shops and should be used in preference to motor oil. Pro Honda HP Chain Lube or an equivalent is recommended.

Saturate each chain joint so that the lubricant penetrates the space between adjacent surfaces of the link plates and rollers.

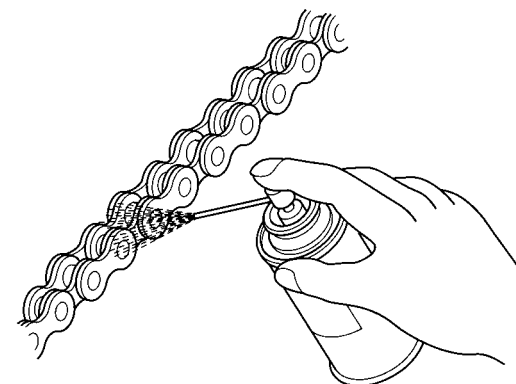

Drive Chain

Removal, Cleaning & Replacement

For maximum service life, the drive chain should be cleaned, lubricated, and adjusted before each outing.

1. Remove the master link retaining clip (1) with pliers.
Do not bend or twist the clip.
2. Remove the master link (2). Remove the drive chain.

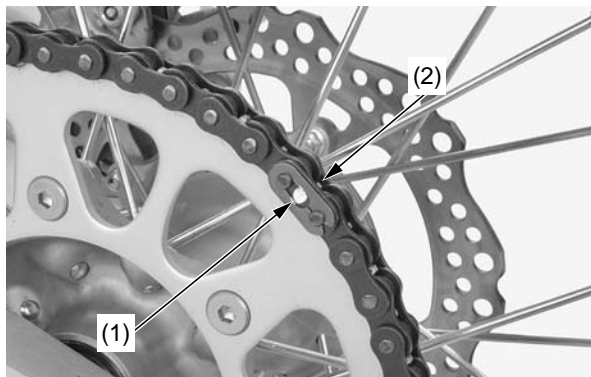

- (1) master link retaining clip
(2) master link

3. Clean the drive chain in high flash-point solvent and allow it to dry.
4. Inspect the drive chain for possible wear or damage. Replace the drive chain if it has damaged rollers, loose fitting links, or otherwise appears unserviceable.

Replacement chain:

Size/link: D.I.D 520DMA4/116RB
RK520TXZ/116RJ

5. Inspect the sprocket teeth for wear or damage. We recommend replacing the sprocket whenever a new chain is installed. Both chain and sprockets must be in good condition, or the new replacement chain or sprocket(s) will wear rapidly. Excessively worn sprocket teeth have a hooked, worn appearance. Replace any sprocket which is damaged or excessively worn.

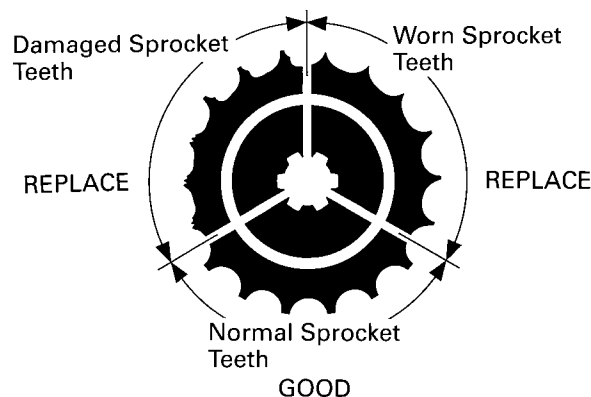

NOTICE

Use of a new chain with worn sprockets will cause rapid chain wear.

6. Measure a section of the drive chain to determine whether the chain is worn beyond its service limit. Put the transmission in gear, and then turn the rear wheel forward until the lower section of the chain is pulled taut. With the chain held taut and any kinked joints straightened, measure the distance between a span of 17 pins, from pin center to pin center. If the measurement exceeds the service limit, replace the chain. After the chain is measured, shift the transmission into neutral again before proceeding with inspection and service.

Replacement chain:

Size/link: D.I.D 520DMA4/116RB
RK520TXZ/116RJ

Service limit: 10.20 in (259.0 mm)

MEASURE A SPAN OF 17 PINS (16 PITCHES)

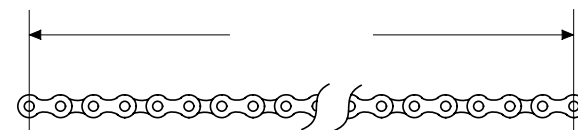

7. Lubricate the drive chain (page 95).
8. Pass the chain over the sprockets and join the ends of the chain with the master link. For ease of assembly, hold the chain ends against adjacent rear sprocket teeth while inserting the master link. Install the master link retaining clip so that the closed end of the clip will face the direction of forward wheel rotation.
9. Recheck chain slack and adjust as necessary.

More About Drive Chain

- The master link is the most critical element of drive chain security. Master links are reusable, as long as they remain in excellent condition. We recommend installing a new master link retaining clip when the drive chain is reassembled.
- You may find it easier to install a new chain by connecting it to the old chain with a master link and pulling the old chain to position the new chain on the sprockets.

Exhaust Pipe/Muffler Inspection

Check the mounting bolts and exhaust pipe joint nuts for tightness.
Check the exhaust pipe and muffler for cracks or deformation.
A damaged exhaust pipe and muffler may reduce engine performance.

Muffler Removal

1. Remove the seat mounting bolt (1), side cover bolt (2) and right side cover (3).

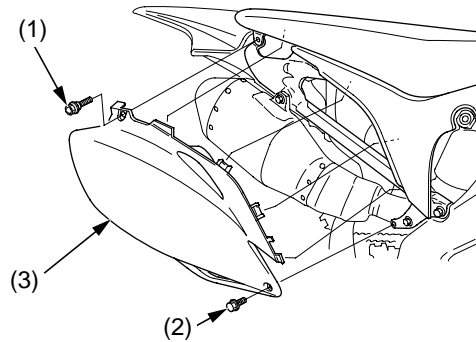

- (1) seat mounting bolt (3) right side cover
(2) side cover bolt

2. Loosen the muffler clamp bolt (4).
3. Remove the muffler mounting A bolt (5), muffler mounting B bolt (6), washers (7) and muffler (8).

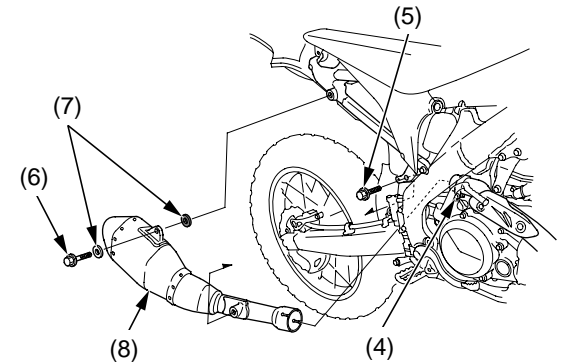

- (4) muffler clamp bolt
(5) muffler mounting A bolt
(6) muffler mounting B bolt
(7) washers
(8) muffler

Exhaust Pipe/Muffler

Muffler Installation

1. Remove the gasket (1).
2. Install the muffler clamp (2) and a new gasket onto the exhaust pipe (3).

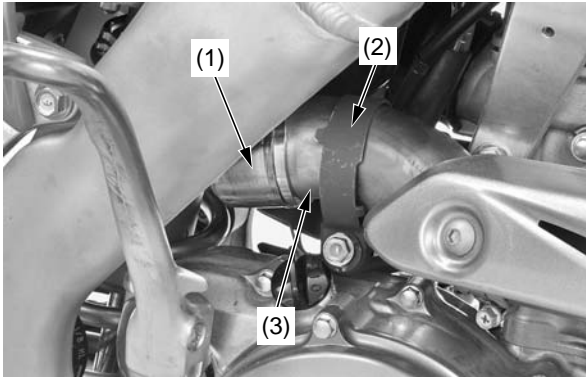

(1) gasket (new) (3) exhaust pipe
(2) muffler clamp

3. Install the muffler (4).
4. Install the muffler clamp (2) by aligning the tab (5) of the muffler clamp with the cutout (6) of the muffler.

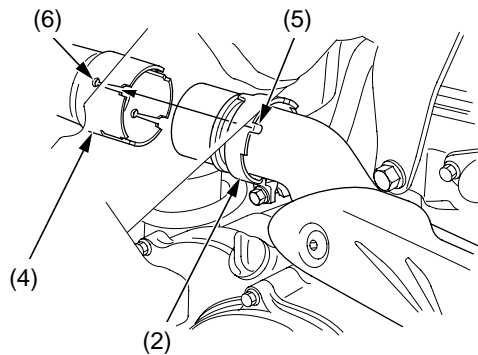

(2) muffler clamp (5) tab
(4) muffler (6) cutout

5. Install the washers (7), muffler mounting B bolt (8) and muffler mounting A bolt (9).

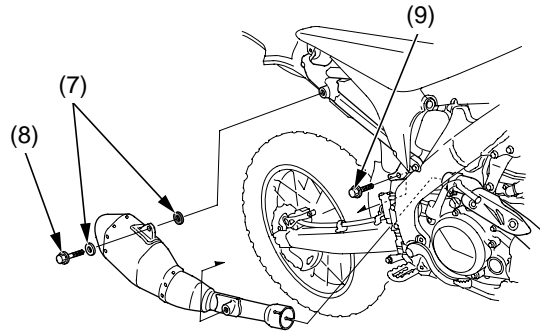

(7) washers
(8) muffler mounting B bolt
(9) muffler mounting A bolt

6. Tighten the muffler clamp bolt (10) to the specified torque:
15 lbf-ft (21 N-m, 2.1 kgf-m)

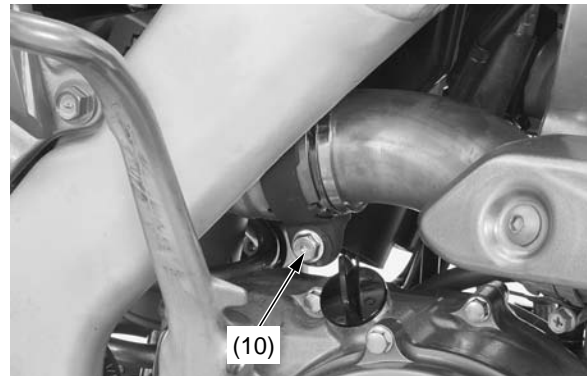

(10) muffler clamp bolt

7. Tighten the muffler mounting B bolt (8) and muffler mounting A bolt (9) to the specified torque:
19 lbf-ft (26 N-m, 2.7 kgf-m)



(8) muffler mounting B bolt
(9) muffler mounting A bolt

8. Install the right side cover (11) and bolt (12).
9. Install the seat mounting bolt (13) and tighten it to the specified torque:
19 lbf-ft (26 N·m, 2.7 kgf·m)
Tighten the bolt (12) to the specified torque:
7 lbf-ft (10 N·m, 1.0 kgf·m)

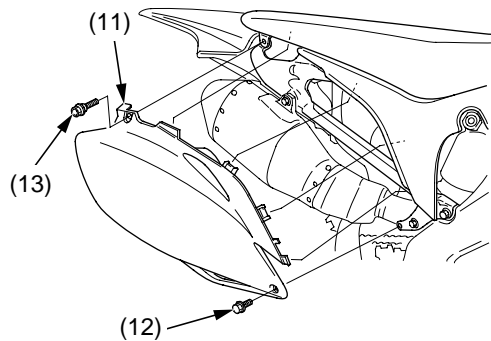

(11) right side cover
(12) bolt
(13) seat mounting bolt

Exhaust Pipe Removal

1. Remove the muffler (page 97).
2. Remove the exhaust pipe joint nuts (1), exhaust pipe (2) and gasket (3).

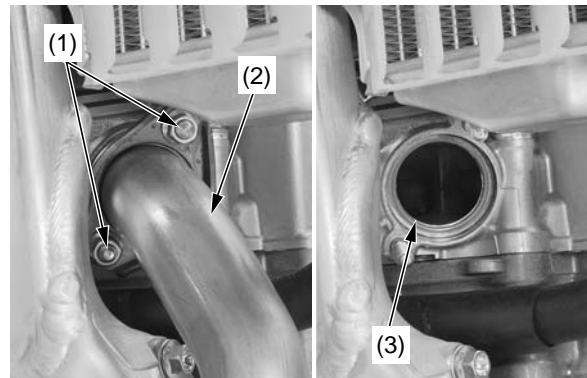

(1) exhaust pipe joint nuts
(2) exhaust pipe
(3) gasket

Exhaust Pipe Installation

1. Install a new exhaust pipe gasket (1) as shown.
2. Install the exhaust pipe (2) and exhaust pipe joint nuts (3).

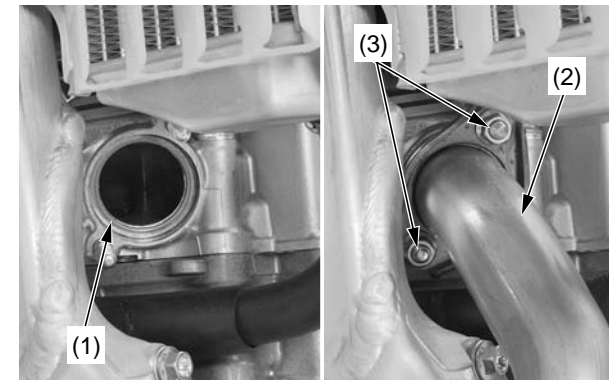

(1) exhaust pipe gasket (new)
(2) exhaust pipe
(3) exhaust pipe joint nuts

3. Install the muffler (page 98) but do not tighten the bolts yet.
4. Tighten the exhaust pipe joint nuts to the specified torque:
15 lbf-ft (21 N·m, 2.1 kgf·m)
5. Tighten the muffler clamp bolt, muffler mounting A bolt and B bolt (page 98).
6. Installation can be done in the reverse order of removal.

Steering Damper

Refer to *Safety Precaution* on page 23.

Loose, worn or damaged steering damper components may adversely affect the handling and stability of your CRF. If any steering damper components appear worn or damaged, see your Honda dealer for further inspection. Your dealer is qualified to determine whether or not replacement parts are needed.

Do not attempt to disassemble the steering damper; see your Honda dealer.

The instructions found in this owner's manual are limited to adjustment and service of the steering damper assembly only.

Steering Damper Operation Inspection

- When your CRF is new, break it in for approximately 1 hour to ensure that the steering damper has worked in (page 19).
- After break-in, test run your CRF with the steering damper at the standard setting before making any adjustments.
- Check the spherical bearings and dust seal for dust, dirt, and foreign materials.
- Make all damping adjustments in one-click increments. (Adjusting two or more clicks at a time may cause you to pass over the best adjustment.) Test ride after each adjustment.
- If you have a problem finding an acceptable adjustment, return to the standard position and begin again.

1. Unlock the number plate tab (1) from the handlebar pad.
Remove the bolts (2) and number plate (3).

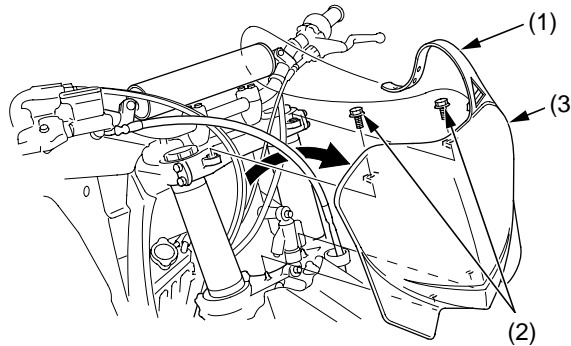

- (1) number plate tab (3) number plate
(2) bolts

2. Check the steering damper (4) for deformation or oil leaks.
Check the damper rod (5) for bending or damage.
Replace the damper case or damper rod if there is any abnormality.
Refer to an official Honda Service Manual or see your Honda dealer for steering damper disassembly.
Check the torque of the steering damper mounting bolts (6):
15 lbf-ft (20 N·m, 2.0 kgf·m)

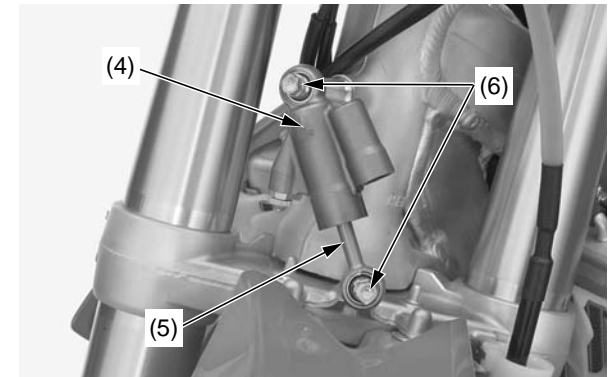

- (4) steering damper
(5) damper rod
(6) steering damper mounting bolts

- With your CRF on a box or an optional workstand (front wheel elevated), check that the steering moves smoothly from side-to-side.



- Install the number plate (3) by aligning its holes (7) with the tabs (8) on the steering stem. Install and tighten the bolts (2). Route the number plate tab (1) around the handlebar pad (9) as shown.

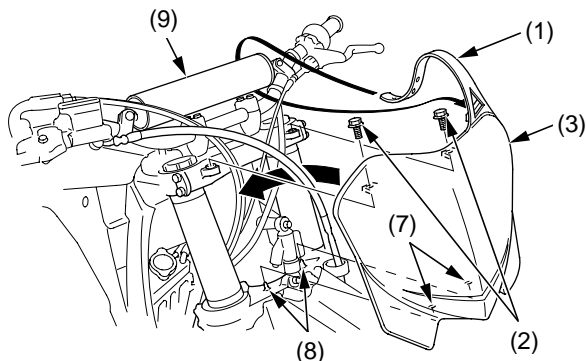

- | | |
|----------------------|-------------------|
| (1) number plate tab | (7) holes |
| (2) bolts | (8) tabs |
| (3) number plate | (9) handlebar pad |

Removal

- Remove the number plate (page 100).
- Remove the steering damper mounting bolts (1), collar (2) and steering damper (3).

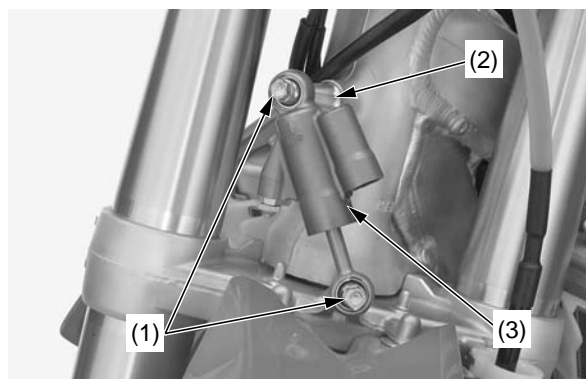

- | |
|------------------------------------|
| (1) steering damper mounting bolts |
| (2) collar |
| (3) steering damper |

Inspection

- Check the damper rod (1) operation. The damper rod is fully extended and compressed by hand. Release the damper rod, then check that it extends to its maximum length.

If the damper rod does not extend to its maximum length, refer to an official Honda Service Manual for disassembly and inspection instructions or see your Honda dealer.

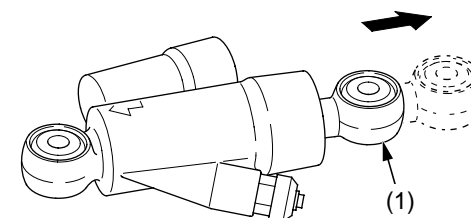

- (1) damper rod

(cont'd)

Steering Damper

2. Check the condition of the spherical bearings (2).
Move the spherical bearing with your finger. The spherical bearing should move smoothly and quietly.

Replace the spherical bearing if it does not move smoothly and quietly.
Refer to an official Honda Service Manual or see your Honda dealer.

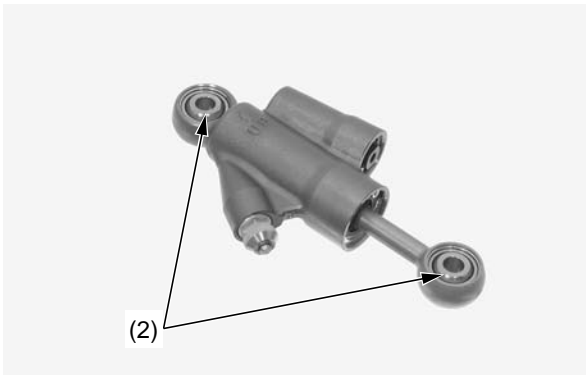

(2) spherical bearings

Installation

1. Clean and apply a locking agent to the steering damper mounting bolt threads.
 2. Install the steering damper (1) with its “UP” mark (2) facing up and forward. Turn the damper rod and its stopper ring (3) facing toward the front side.
 3. Install the collar (4) and steering damper mounting bolts (5).
- Be sure to install the collar with its wide flange side facing toward the steering head pipe side.
4. Tighten the steering damper mounting bolts to the specified torque:
15 lbf·ft (20 N·m, 2.0 kgf·m)

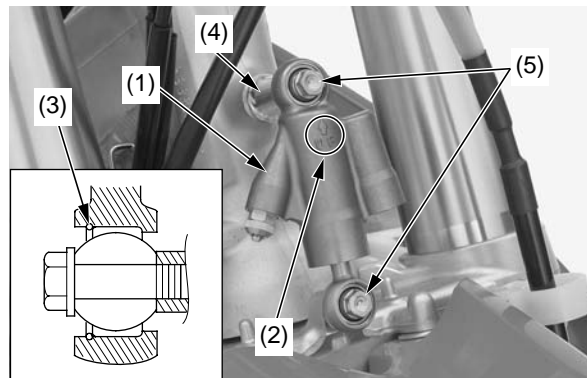

- (1) steering damper
- (2) “UP” mark
- (3) stopper ring
- (4) collar
- (5) steering damper mounting bolts

5. With your CRF on a box or an optional workstand (front wheel elevated), check that the steering moves smoothly from side to side.



6. Install the number plate (page 101).

Refer to *Safety Precautions* on page 23.

Steering Head Bearing Inspection

1. With your CRF on a box or optional workstand (front wheel elevated), turn the handlebar to the right and left to check for roughness in the steering head bearings.



2. Stand in front of your CRF, grab the fork (at the axle), look at the steering head, and push the fork in and out (toward the engine) to check for play in the steering head bearings. If any roughness or play is felt, but you do not see any movement in the steering head, the fork bushings may be worn. Refer to an official Honda Service Manual for replacement or adjustment procedures, or see your Honda dealer.

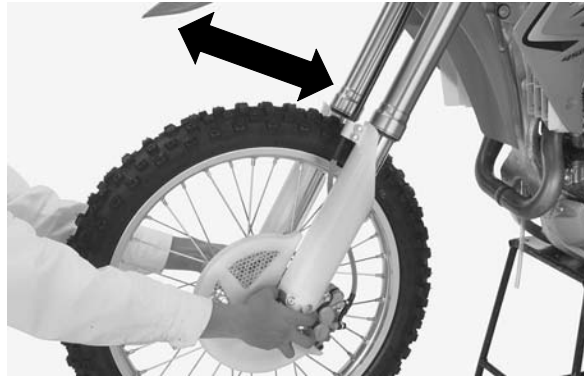

Handlebar Inspection

1. Check the handlebar (1) for bends or cracks.
2. Check that the handlebar has not moved from its proper position the end of the right handlebar holders (2) is aligned with the paint mark (3).
3. Check the torque of the handlebar upper holder bolts (4):
16 lbf-ft (22 N·m, 2.2 kgf·m)
Tighten the front bolts first.

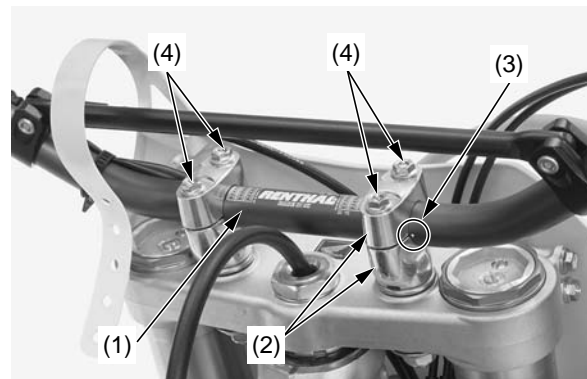

- (1) handlebar
- (2) right handlebar holders
- (3) paint mark
- (4) handlebar upper holder bolts

Control Cables

Periodically, disconnect the throttle and clutch cables at their upper ends. Thoroughly lubricate the cable pivot points with a commercially available cable lubricant. If the clutch lever and throttle operation is not smooth, replace the cable.

Be sure the throttle returns freely from fully open to fully closed automatically, in all steering positions.

Additional Maintenance Procedures

Nuts, Bolts, Fasteners

Check and tighten nuts, bolts, and fasteners before every outing.

ENGINE

	Item	Torque		
		lbf•ft	N•m	kgf•m
1	Cylinder head cover socket bolts	7	10	1.0
2	Clutch cover bolts	7	10	1.0
3	Water pump cover bolts	7	10	1.0
4	Transmission oil check bolt	9	12	1.2
5	Crankshaft hole cap	11	15	1.5
6	Oil filter cover bolts	9	12	1.2
7	Cylinder head bolts	38	51	5.2
8	Exhaust pipe joint nuts	15	21	2.1
9	Drive sprocket bolt	23	31	3.2
10	Engine oil drain bolt	12	16	1.6
11	Transmission oil drain bolt	12	16	1.6
12	Coolant drain bolt	7	10	1.0
13	Water hose joint bolts	7	10	1.0

RIGHT SIDE

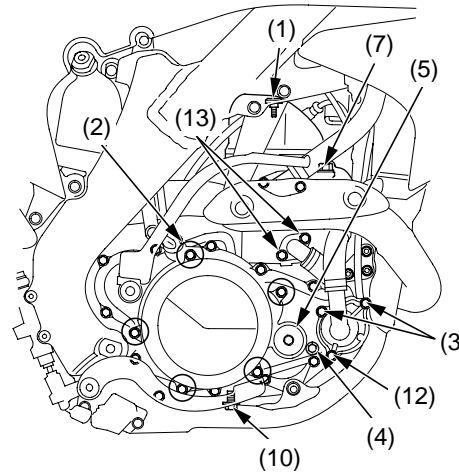

- (1) cylinder head cover socket bolts
- (2) clutch cover bolts
- (3) water pump cover bolts
- (4) transmission oil check bolt
- (5) crankshaft hole cap
- (7) cylinder head bolts
- (10) engine oil drain bolt
- (12) coolant drain bolt
- (13) water hose joint bolts

LEFT SIDE

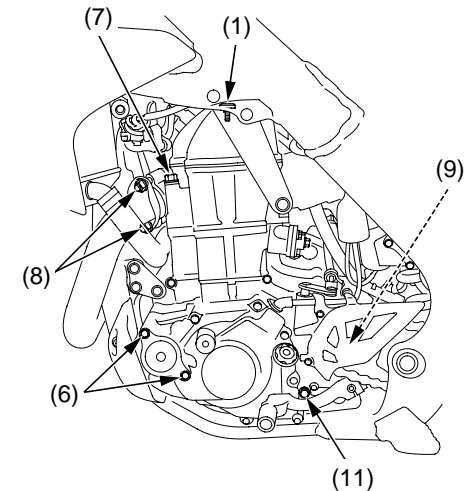

- (1) cylinder head cover socket bolts
- (6) oil filter cover bolts
- (7) cylinder head bolts
- (8) exhaust pipe joint nuts
- (9) drive sprocket bolt
- (11) transmission oil drain bolt

Refer to *Safety Precautions* on page 23.

Frequent cleaning and polishing will keep your CRF looking newer longer. Frequent cleaning also identifies you as an owner who values his motorcycle. A clean CRF is also easier to inspect and service.

While you're cleaning, be sure to look for damage, wear, and gasoline or oil leaks.

General Recommendations

- To clean your CRF you may use:
 - water
 - a mild, neutral detergent and water
 - a mild spray and wipe cleaner/polisher
 - a mild spray and rinse cleaner/degreaser and water
- Avoid products that contain harsh detergents or chemical solvents that could damage the metal, paint, and plastic on your CRF or discolor the seat and decals.
- If your CRF is still warm from recent operation, give the engine and exhaust system time to cool off.
- We recommend the use of a garden hose to wash your CRF. High pressure washers (like those at coin-operated car washes) can damage certain parts of your CRF. The force of water under extreme pressure can penetrate the dust seals of the suspension pivot points and steering head bearings-driving dirt inside and needed lubrication out.

If you use a high pressure washer, avoid spraying the following areas:

- brake master cylinders
- drive chain
- electrical circuit
- muffler outlet
- steering head bearings
- suspension pivot points
- throttle body
- under fuel tank
- under seat

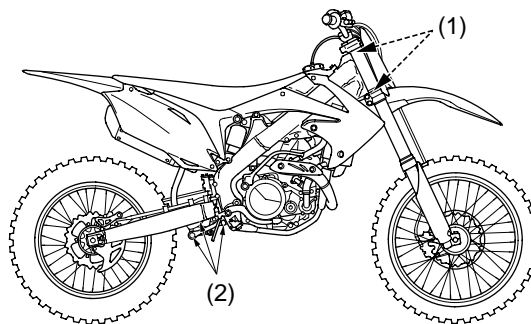

- (1) steering head bearings
- (2) suspension pivot points

NOTICE

High pressure water (or air) can damage certain parts of your CRF.

You may use Pro Honda Hondabrite, a multi-surface cleaner/degreaser, to remove both dirt and petroleum-based grime from paint, alloy, plastic, and rubber surfaces. Wet any heavy deposits with water first. Then spray on the Pro Honda Hondabrite and rinse with a garden hose at full pressure. Stubborn deposits may require a quick wipe with a sponge.

Washing Your Motorcycle with a Mild Detergent

1. Rinse your CRF thoroughly with cool water to remove loose dirt.
2. Fill a bucket with cool water. Mix in a mild, neutral detergent, such as dish washing liquid or a product made especially for washing motorcycles or automobiles.
3. Wash your CRF with a sponge or a soft towel. As you wash, check for heavy grime. If necessary, use a mild cleaner/degreaser to remove the grime.

NOTICE

Do not use steel wool to clean the frame as it could damage or discolor the frame surface. Muffler stain remover (Scotch Brite Hand Pad #7447-maroon) is for removing stains on the non-coated aluminum frame only.

4. After washing, rinse your CRF thoroughly with plenty of clean water to remove any residue.
5. Dry your CRF with a chamois or a soft towel.
6. Lubricate the drive chain to prevent rusting.
7. Start the engine and let it idle for several minutes. The engine heat will help dry moist areas.
8. As a precaution, ride at a slow speed and apply the brakes several times. This will help dry the brakes and restore normal braking performance.

Appearance Care

Condensation Control

Some condensation can form within the transmission cavity as well. This is natural and just one more reason you should change the engine and transmission oil often.

After Cleaning Lubrication

There are some things you should do just after washing your CRF to help prevent rust and corrosion.

Once your CRF is clean and dry, you should protect any bare steel from rusting by applying a light coating of a rust-inhibitor. Lubricate the drive chain and drive sprocket after removing and thoroughly cleaning in solvent. Be sure the chain is wiped clean and is dry before applying the chain lube.

Follow the suggestions given in the pages of this manual for lubricating items such as the brake and clutch lever pivot points and footpeg pivot pins.

Aluminum Frame Maintenance

Aluminum corrodes when it comes in contact with dust, mud and road salt.

To remove stains, use Scotch Brite Hand Pad #7447 (maroon) or an equivalent.

Wet the pad and polish the surface using strokes parallel to the length of the frame.

Clean the frame using a wet sponge and a mild detergent, then rinse well with clean water. Dry the frame with a soft clean cloth, using strokes parallel to the length of the frame.

NOTICE

Do not use steel wool to clean the frame as it could damage or discolor the frame surface. Muffler stain remover (Scotch Brite Hand Pad #7447-maroon) is for removing stains on the non-coated aluminum frame only.

Exhaust Pipe Maintenance

The exhaust pipe is stainless steel, but may become stained by oil or mud.

To remove mud or dust, use a wet sponge and a liquid kitchen abrasive, then rinse well with clean water. Dry with a chamois or a soft towel. If necessary, remove heat stains by using a commercially available fine texture compound. Then rinse by the same manner as removing mud or dust.

This section tells you how to fine tune your CRF for maximum competition performance.

Initial suspension adjustments should be performed after a minimum of 2 hours of easy break-in time.

Optional front and rear suspension springs are available in both stiffer and softer than standard rates, in order to tailor your CRF specifically for your weight, riding style and course conditions.

Follow the instructions given in the rear suspension sag setting section of *Rear Suspension Adjustments* to determine if your combined rider and sprung machine weight (rider fully dressed for competition and machine coolant, oil and fuel levels ready for competition) requires an optional stiffer or softer rear spring. The need for either optional rear spring may need to be balanced by installing the optional fork springs of a similar rate.

Front Suspension Adjustments.....	108
Front Suspension Air Pressure.....	108
Front Suspension Damping	109
Fork Springs.....	109
Front Suspension Disassembly	110
Damper Oil Change	113
Fork Assembly	116
Rear Suspension Adjustments.....	122
Rear Suspension Spring Pre-Load.....	122
Rear Suspension Damping.....	123
Rear Suspension Race Sag	124
Suspension Adjustments for Track	
Conditions.....	126
Suspension Adjustment Guidelines.....	127
Tuning Tips	130
Spark Plug Reading	130
Steering Damper Adjustment	131
Steering Damper Damping	131
Steering Damper Adjustment Guidelines.....	132
Chassis Adjustments.....	133
Rear End	133
Fork Height/Angle	133
Wheelbase.....	133
Gearing	134
Tire Selection for Track Conditions.....	135
Personal Fit Adjustments	136
Control Positioning.....	136
Handlebar Position, Width & Shape.....	136

Front Suspension Adjustments

The front suspension can be adjusted for the rider's weight and riding conditions by using one or more of the following methods:

- **Oil volume** — The effects of higher or lower fork oil capacity are only felt during the final 3.9 in (100 mm) of fork travel.
- **Compression damping** — Turning the compression damping adjuster (1) adjusts how quickly the fork compresses.
- **Rebound damping** — Turning the rebound damping adjuster (2) adjusts how quickly the fork extends.
- **Fork springs** — Optional springs are available in softer and stiffer types than the standard rate (page 152).

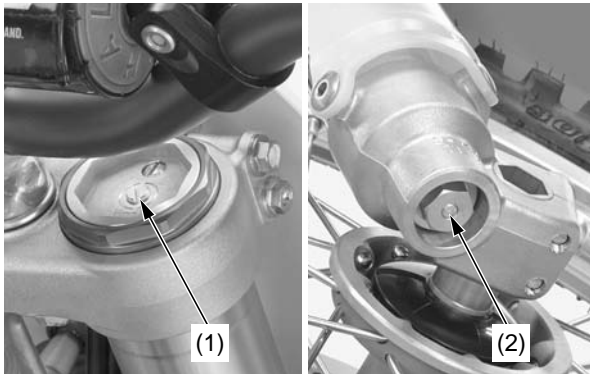

(1) compression damping adjuster
(2) rebound damping adjuster

Front Suspension Air Pressure

Air is an unstable gas which builds up pressure as it is worked (such as in a fork). Air pressure acts as a progressive spring and affects the entire range of fork travel. This means the fork action on your CRF will get stiffer during a race. For this reason, release built-up air pressure in the fork legs between motos. Be sure the fork is fully extended with the front tire off the ground when you release the pressure.

The standard air pressure is 0 psi (0 kPa, 0 kgf/cm²). You may relieve accumulated air pressure in the fork legs by using the fork air pressure release screws. The front wheel should be off the ground before you release the pressure. The air pressure should be adjusted according to the altitude and outside temperature.

1. Place an optional workstand under the engine, so that the front wheel is off the ground. Do not adjust air pressure with the front wheel on the ground as this will give false pressure readings.
2. Remove the fork air pressure release screw (1).
3. Check that the O-ring (2) is in good condition.

4. Install and tighten the fork air pressure release screw to the specified torque:
0.9 lbf-ft (1.2 N·m, 0.1 kgf-m)

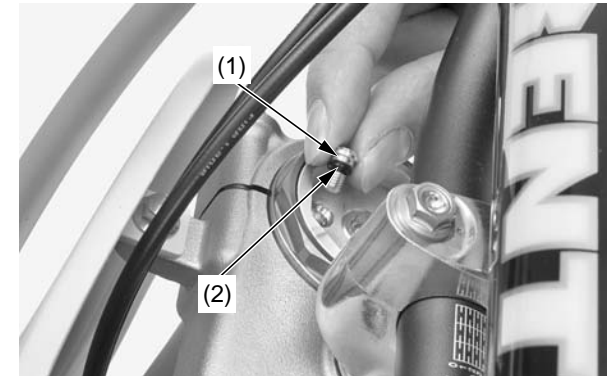

(1) fork air pressure release screw (2) O-ring

Front Suspension Damping

Compression Damping Adjustment

This adjustment affects how quickly the fork compresses. The fork compression damping adjuster (1) has 18 positions or more. Turning the adjuster screw one full turn changes the adjuster four positions. To adjust the compression damping to the standard position, proceed as follows:

Turn the adjuster clockwise until it will no longer turn (lightly seats). This is the full hard position. The adjuster is set in the standard position when the adjuster is turned counterclockwise 13 clicks. Make sure that both fork legs are adjusted to the same position.

Rebound Damping Adjustment

The fork rebound damping adjuster (2) has 16 positions or more. Turning the adjuster screw one full turn clockwise advances the adjuster four positions. To adjust the rebound damping to the standard setting, proceed as follows:

Turn the adjuster clockwise until it will no longer turn (lightly seats). This is the full hard position. The adjuster is set in the standard position when the adjuster is turned counterclockwise 8 clicks. Make sure that both fork legs are adjusted to the same position.

Both compression and rebound damping can be increased by turning the adjuster clockwise.

NOTICE

Always start with full hard when adjusting damping.

Do not turn the adjuster screw more than the given positions or the adjuster may be damaged. Be sure that the compression and rebound adjusters are firmly located in a detent, and not between positions.

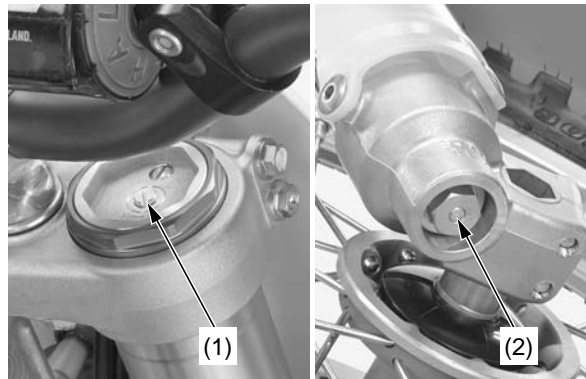

(1) compression damping adjuster (2) rebound damping adjuster

Fork Springs

The fork springs in CRF's are about right for riders weighing between 150 lbs (68 kg) and 160 lbs (73 kg) (less riding gear). So if you're a heavier rider, you have to go up on the oil capacity or get a stiffer spring. Do not use less oil than the minimum specified for each spring or there will be a loss of rebound damping control near full extension. If the fork is too hard on big bumps, turn the damping adjuster counterclockwise 1-turn and lower the oil capacity in increments of 0.2 US oz (5 cm³) in both fork legs until the desired performance is obtained. Do not, however, lower the oil capacity below the minimum oil capacity.

Minimum oil capacity:

- Standard spring: 10.3 US oz (305 cm³)
- Softer spring: 10.2 US oz (303 cm³)
- Stiffer spring: 10.1 US oz (300 cm³)

When adjusting oil capacity, bear in mind that the air in the fork will increase in pressure while riding; therefore, the higher the oil capacity, the higher the eventual pressure of any air in the fork.

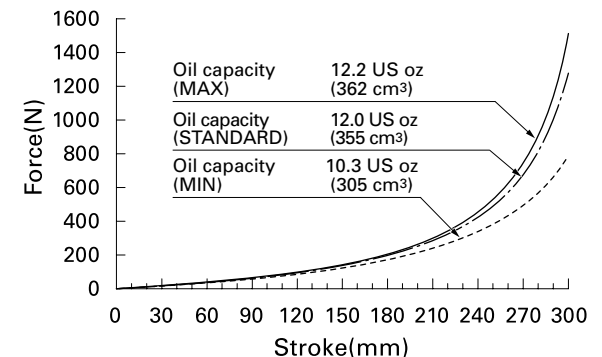

Front Suspension Adjustments

Front Suspension Disassembly

- If your CRF is brand-new, put enough part-throttle break-in time (about 1 hour) on it to ensure that the suspension has worked in.
- For optimum performance, and extended fork life, the fork should be completely disassembled and cleaned after the first 3 hours of riding. See an official Honda Service Manual or your Honda dealer for this service.
- When disassembling the fork, turn the compression (1) and rebound (2) damping adjusters counterclockwise to the softest position to prevent damaging the adjustment needle (be sure to record the number of turns from the starting position).

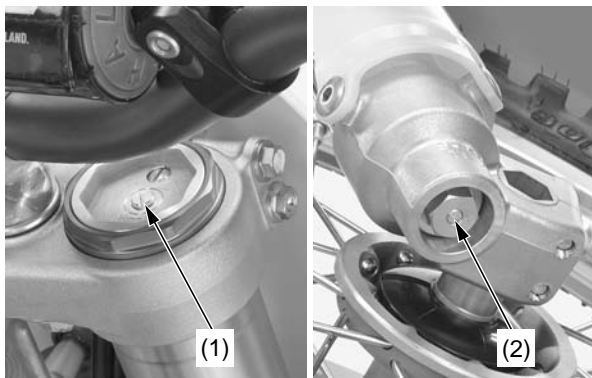

(1) compression damping adjuster

(2) rebound damping adjuster

1. Remove the number plate (page 100).
2. Place your CRF on an optional workstand or equivalent support with the front wheel off the ground.
3. Remove the handlebar lower holder nuts, washers, mounting rubbers (3) and handlebar (4).

NOTICE

Keep the master cylinder upright to prevent air from entering system.

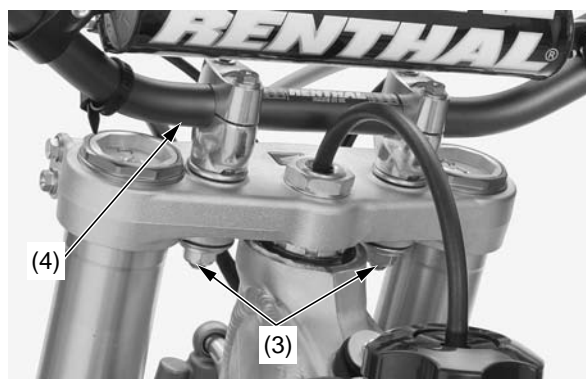

- (3) handlebar lower holder nuts, washers and mounting rubbers
(4) handlebar

4. Loosen the fork bridge upper pinch bolts (5).
 5. Loosen the fork damper (6) using a lock nut wrench (7), but do not remove them yet.
- Lock nut wrench 07WMA-MEN0100

NOTICE

Do not use an adjustable wrench to loosen the fork damper: it may damage them.

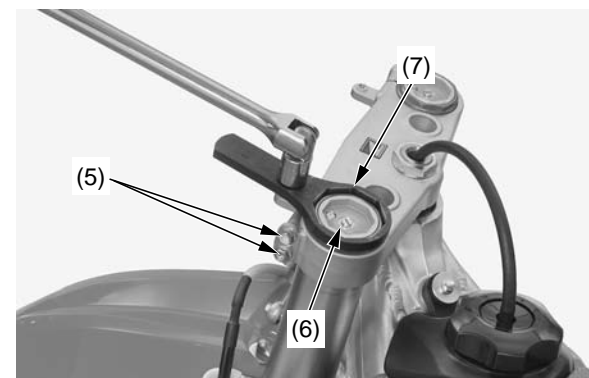

- (5) fork bridge upper pinch bolts
(6) fork damper
(7) lock nut wrench

6. Remove the disc cover socket bolt (8).

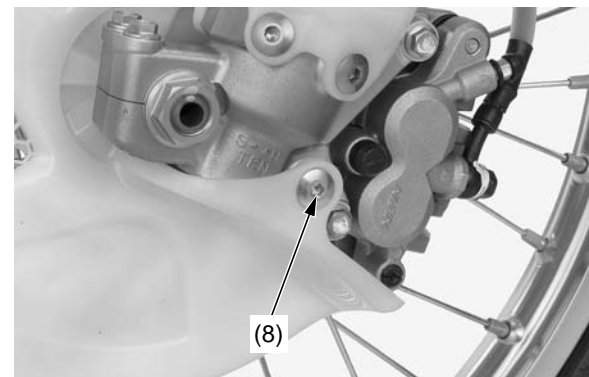

- (8) disc cover socket bolt

Front Suspension Adjustments

7. Remove the front axle nut (9) and loosen the axle pinch bolts (10) on both forks. Pull the front axle shaft (11) out of the wheel hub and remove the front wheel with disc cover/collar.

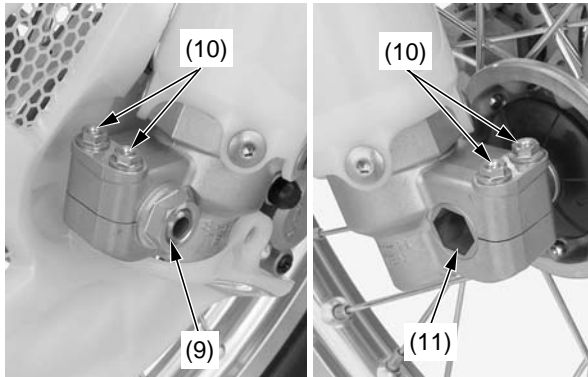

(9) front axle nut
(10) axle pinch bolts
(11) front axle shaft

8. Remove the brake hose clamp bolts (12), stay A (13) and stay B (14).
9. Remove the brake caliper mounting bolts (15) and brake caliper (16).
- Do not support the brake caliper by the brake hose.
 - Do not operate the brake lever after the front wheel is removed. To do so will cause difficulty in fitting the brake disc between the brake pads.

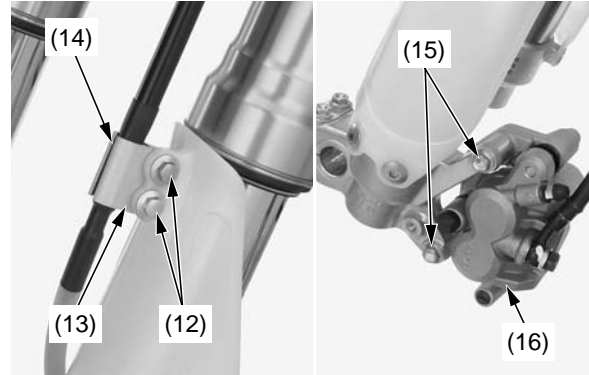

(12) brake hose clamp bolts
(13) stay A
(14) stay B
(15) brake caliper mounting bolts
(16) brake caliper

10. Remove the fork protector socket bolts (17) and fork protectors (18).

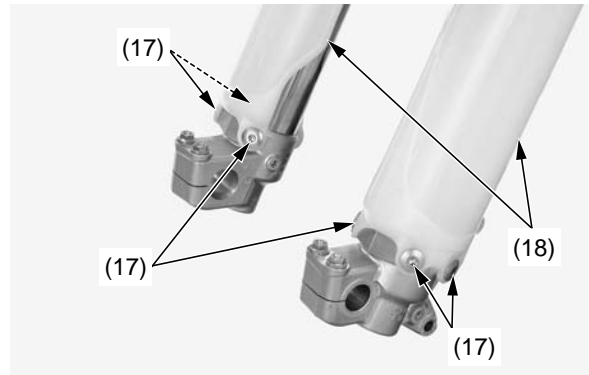

(17) fork protector socket bolts
(18) fork protectors

11. Loosen the fork bridge lower pinch bolts (19), then pull the fork legs down and out.

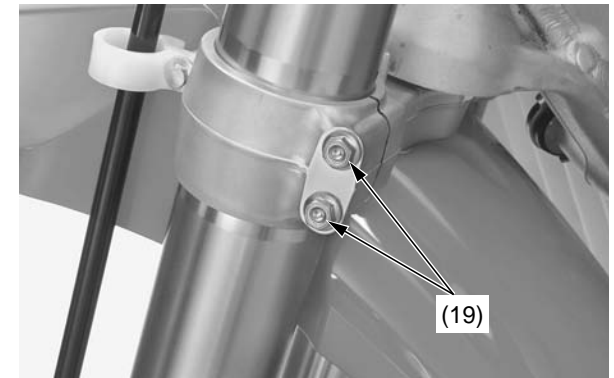

(19) fork bridge lower pinch bolts

12. Clean the fork assembly, especially the sliding surface (20) of the slider and fork dust seal (21).
13. Measure the length (22) between the axle holder and outer tube and record it before disassembling the fork.

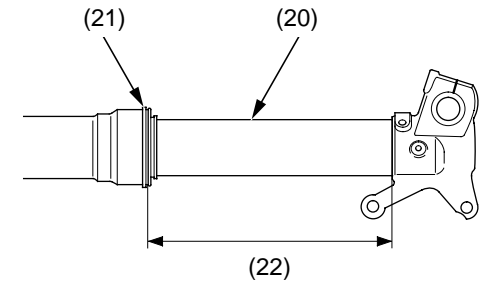

(20) sliding surface
(21) fork dust seal
(22) length

(cont'd)

Front Suspension Adjustments

14. Hold the outer tube, then remove the fork damper (6) from the outer tube using a lock nut wrench (7). Gently slide the outer tube down onto the lower end (axle holder) (23).

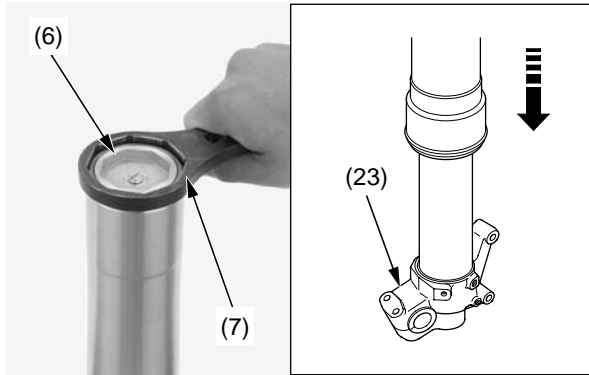

(6) fork damper
(7) lock nut wrench
(23) axle holder

NOTICE

The outer tube (24) can drop on the slider (25) and damage the fork dust seal (21). To avoid damage, hold both the outer tube and slider when removing the fork damper.

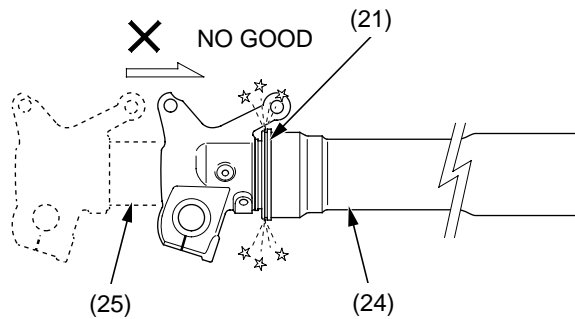

(21) fork dust seal
(24) outer tube
(25) slider

15. Drain the fork oil from the outer tube/slider (26) and oil holes (27) of the fork damper.

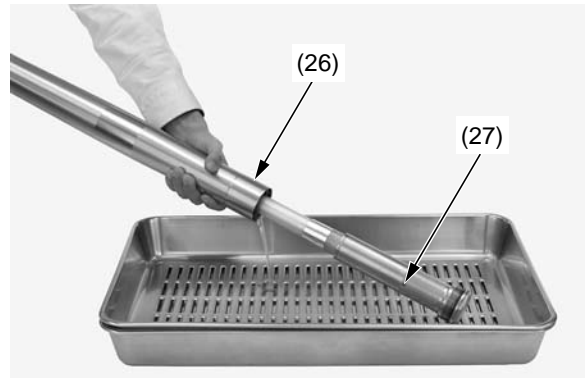

(26) outer tube/slider
(27) oil holes

16. Place the lower end (axle holder) (23) of the slider in a vise with a piece of wood or soft jaws to avoid to damage.

NOTICE

Over-tightening the vice can damage the axle holder.

17. Remove the fork center bolt (28).

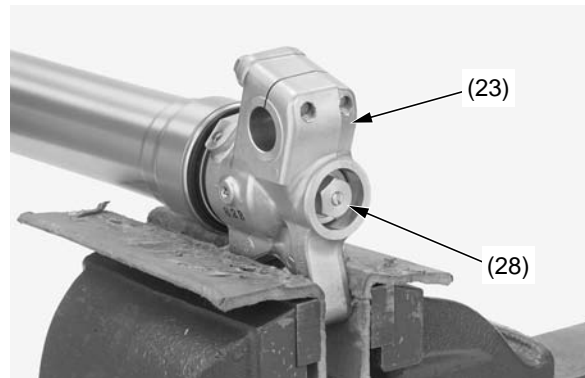

(23) axle holder
(28) fork center bolt

18. Make the mechanic's stopper tool out of a thin piece of steel (0.08 in (2.0 mm) thick) as shown if you do not have a special tool.

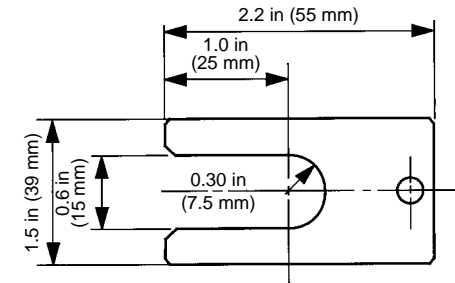

19. Push the fork center bolt (28) out from the axle holder (23) of the slider by pushing the fork damper. While the fork center bolt is pushed out, install the piston base (29) or a mechanic's stopper tool between the axle holder and fork center bolt lock nut (30).
- Piston base 07958-2500001
20. Hold the fork center bolt lock nut and remove the fork center bolt from the fork damper.

NOTICE

Do not remove the lock nut from the fork damper piston rod. If the lock nut is removed, the piston rod will fall in the fork damper and you may not reassemble the fork damper.

Front Suspension Adjustments

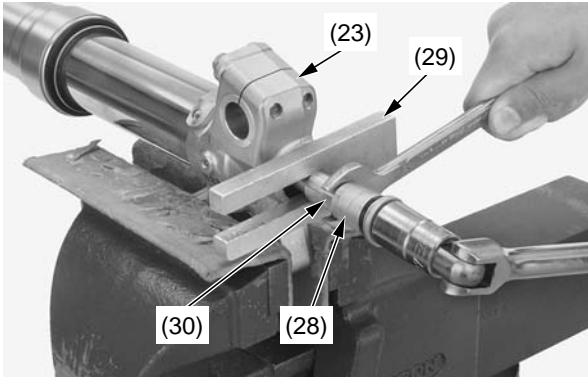

(23) axle holder
(28) fork center bolt
(29) piston base
(30) fork center bolt lock nut

21. Remove the push rod (31) from the fork damper.
22. Remove the piston base (29) or mechanic's stopper tool between the axle holder (23) and fork center bolt lock nut (30) while pushing the fork damper.

NOTICE

Be careful not to damage the lock nut and fork center bolt hole.

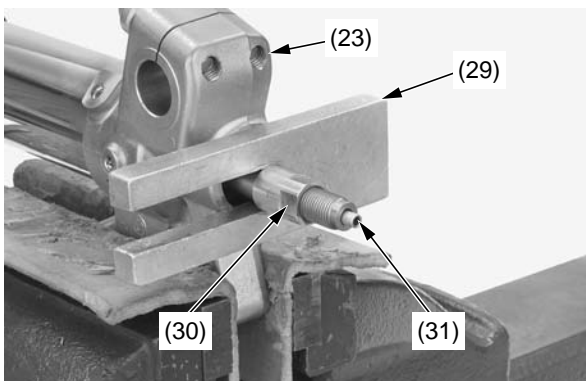

(23) axle holder
(29) piston base
(30) fork center bolt lock nut
(31) push rod

23. Remove the fork damper assembly (32) from the fork assembly (33).
Remove the fork from the vise.
Remove the fork spring (34) and spring retainer (35) from the fork assembly. Remove the O-ring (36).

NOTICE

Do not attempt to separate the fork assembly and drop the axle holder out from the outer tube, which can damage the guide bushings (37). To avoid damage, hold both the outer tube and slider.

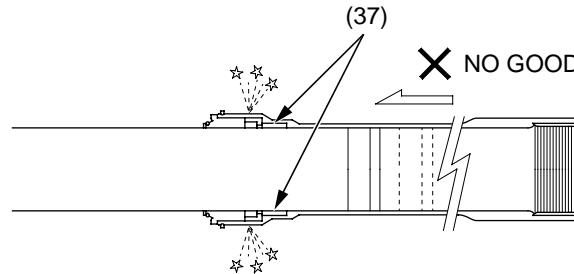

(37) guide bushings

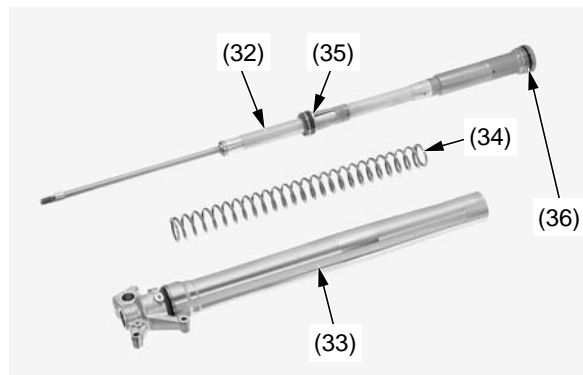

(32) fork damper assembly
(33) fork assembly
(34) fork spring
(35) spring retainer
(36) O-ring

Damper Oil Change

1. Place the fork damper (1) in a vise with a piece of wood or soft jaws to avoid damage.

NOTICE

Over-tighten the vice can damage the axle holder.

2. Loosen the fork cap assembly (2) while holding the fork damper (1) using the following tools:

- Fork cap bolt holder, 36 mm (3)
070MB-MEN0100
- Lock nut wrench (4)
070MA-MEN0100

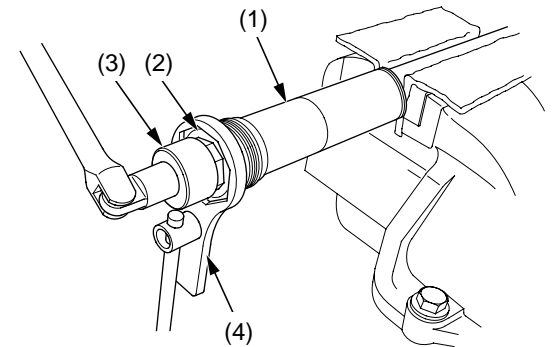

(1) fork damper
(2) fork cap assembly
(3) fork cap bolt holder, 36 mm
(4) lock nut wrench

(cont'd)

Front Suspension Adjustments

- Remove the fork cap assembly (2) from the fork damper threads and then pop it out by pumping the fork damper piston rod (5) slowly.
- Remove the fork cap assembly (2).

Be careful not to damage the fork cap bushings. Do not disassemble the fork cap assembly. Replace the fork cap as an assembly if it is damaged.

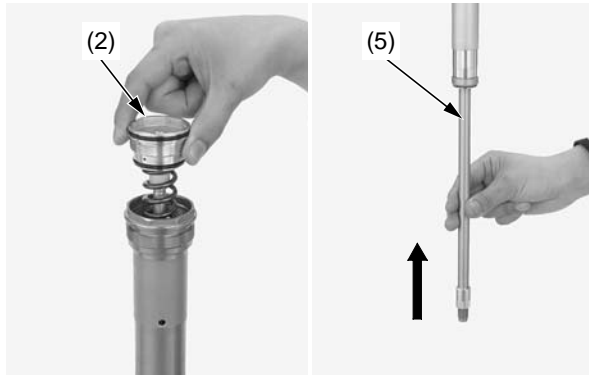

(2) fork cap assembly (5) fork damper piston rod

- Empty the fork oil from the oil holes (6) of the fork damper oil/spring chamber (7) by pumping the damper rod several times.

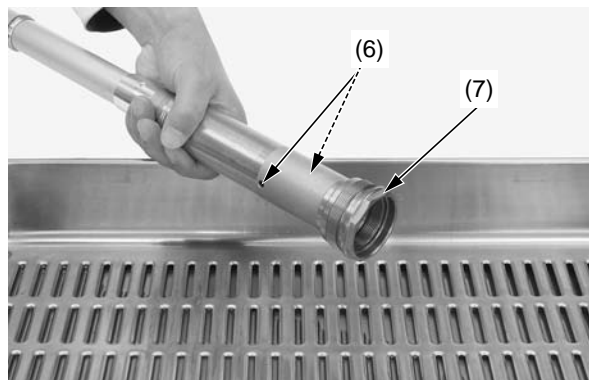

(6) oil holes
(7) fork damper oil/spring chamber

- Clean the fork cap and fork damper threads (8).

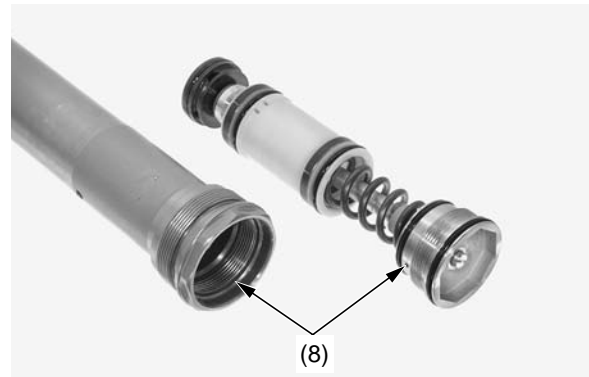

(8) fork cap and fork damper threads

- Extend the fork damper piston rod to maximum length. Pour the recommended fork oil into the fork damper (1).
Recommended Oil:
KHL15-11 (KYB)
Recommended Amount:
7.1 US oz (211 cm³)

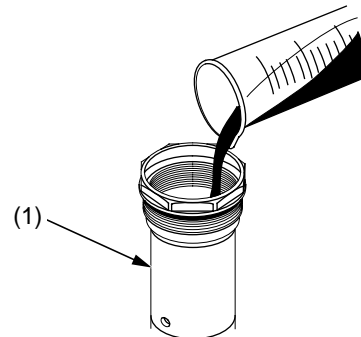

(1) fork damper

- Pump the fork damper piston rod (5) slowly several times to bleed the air from the fork damper (1).

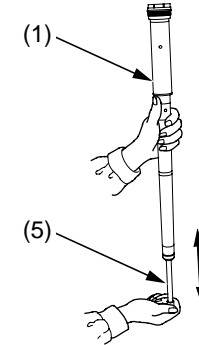

(1) fork damper (5) fork damper piston rod

- Apply fork oil to the fork cap bushings (9) and new O-rings (10) on the fork cap assembly (2).

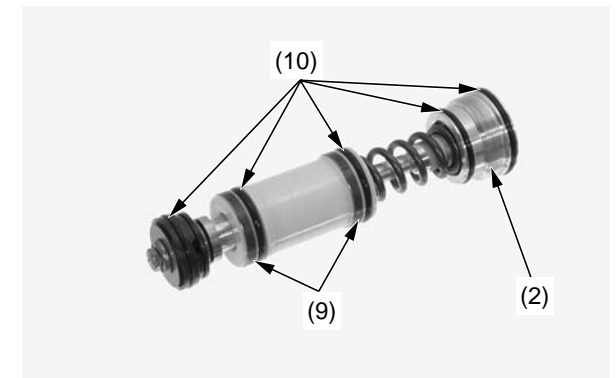

(2) fork cap assembly
(9) fork cap bushings (10) O-rings (new)

Front Suspension Adjustments

10. Extend the fork damper piston rod (5) to maximum length, holding it, install the fork cap assembly (2) to the fork damper (1).

Be careful not to damage the fork cap piston ring. If it is difficult to install the fork cap assembly, the fork damper oil level might be higher than standard oil level.

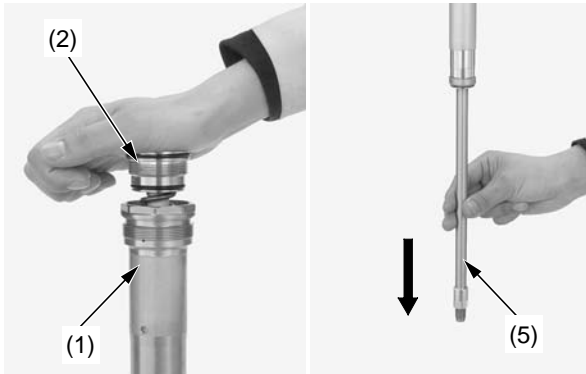

(1) fork damper
(2) fork cap assembly
(5) fork damper piston rod

11. Place the fork damper (1) in a vise with a piece of wood or soft jaws to avoid damage. Tighten the fork cap assembly (2) using the fork cap bolt holder, 36 mm (3) while holding the cutout of the fork damper using the lock nut wrench (4) to the specified torque:
21 lbf·ft (28 N·m, 2.9 kgf·m)

- Fork cap bolt holder, 36 mm 070MB-MEN0100
- Lock nut wrench 070MA-MEN0100

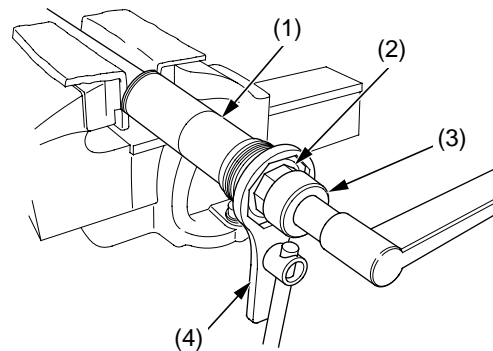

(1) fork damper (3) fork cap bolt holder, 36 mm
(2) fork cap assembly (4) lock nut wrench

12. Completely screw in the fork center bolt lock nut (11) to the fork damper piston rod (5).

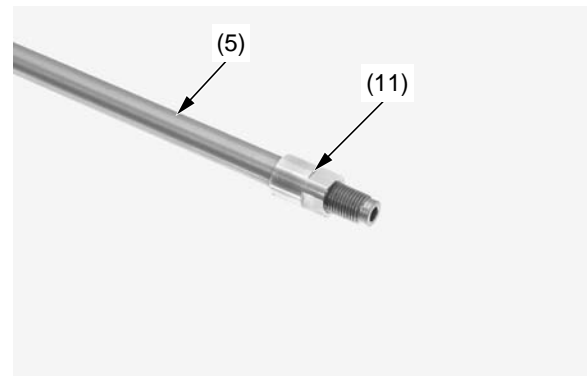

(5) fork damper piston rod (11) fork center bolt lock nut

13. Check the fork damper piston rod sliding surface for damage.
14. Cover the fork damper piston rod end with soft jaws (12) to prevent fork damage. Cover the oil holes with shop towel (13) to prevent blow out of fork oil. Blow the extra oil off from the fork damper oil/spring chamber (7) by pumping the fork damper piston rod to full stroke.

NOTICE

Be careful not to bend or damage the fork damper piston rod when the piston rod is stroked.

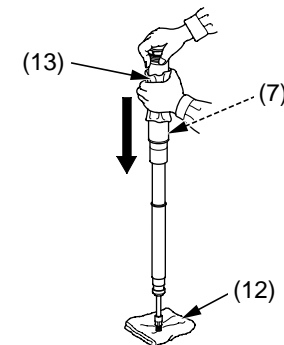

(7) fork damper oil/spring chamber
(12) soft jaws
(13) shop towel

(cont'd)

Front Suspension Adjustments

- Drain the extra oil from the oil holes (6) of the fork damper oil/spring chamber (7).

By doing above procedure, about 0.3 US oz (10 cm³) of fork fluid will be drained from the damper oil/spring chamber through the oil hole and cause 6.8 US oz (201 cm³) of fork fluid to be left in the chamber.

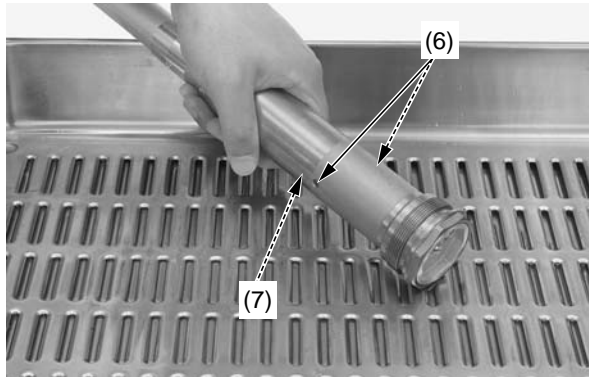

(6) oil holes (7) fork damper oil/spring chamber

Pour the drained oil into a suitable container and dispose of it in an approved manner (page 140).

NOTICE

Improper disposal of drained fluids is harmful to the environment.

Fork Assembly

- Drain the fork oil from the fork assembly (1) by placing it upside down. (About 0.3 US oz (9.8 cm³) of fork oil will be left in the outer tube/slider when it is left inverted for about 20 minutes at 68°F/20°C)

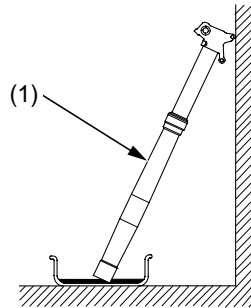

(1) fork assembly

To properly dispose of drained fluids, refer to *You & the Environment* (page 140).

NOTICE

Improper disposal of drained fluids is harmful to the environment.

Amount of fork oil left in the fork (without damper and spring) unit: cm³

minute °F/°C	5	10	20	35	55	85	145
32/0	16.1	14.2	12.4	10.8	9.8	8.4	7.0
50/10	14.9	12.5	11.3	9.5	8.0	6.9	5.8
68/20	13.2	11.4	9.8	7.8	6.6	5.1	4.7
86/30	12.5	10.2	8.2	6.9	5.8	4.4	3.6

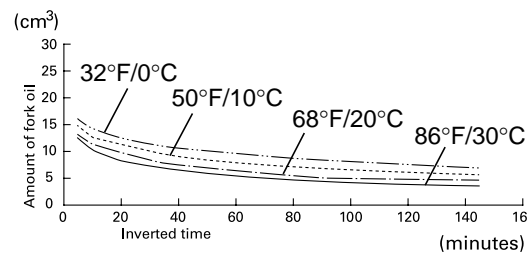

- Tighten the fork center bolt lock nut (2) fully and measure the thread length (A) as shown. Standard: 0.6 – 0.7 in (16 – 18 mm) Wipe the oil completely off the fork damper.

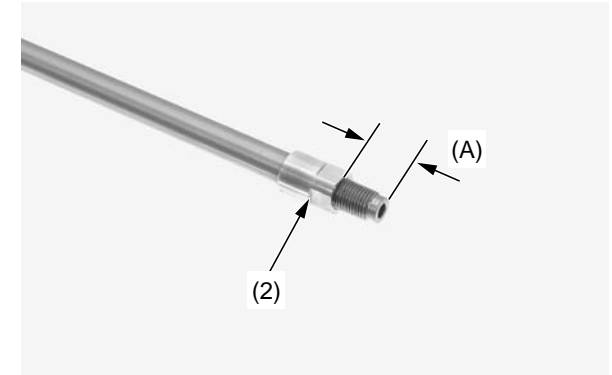

(2) fork center bolt lock nut (A) thread length

- Blow out the oil completely off the fork spring (3) using compressed air. Install the fork spring and spring retainer (4) to the fork damper assembly (5). Install the fork damper assembly to the fork assembly (1).

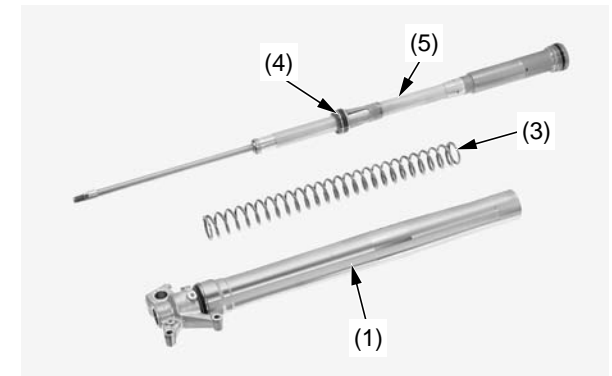

(1) fork assembly (3) fork spring (4) spring retainer (5) fork damper assembly

Front Suspension Adjustments

- Place the lower end (axle holder) of the slider in a vise with a piece of wood or soft jaws to avoid to damage.

NOTICE

Over-tightening the vise can damage the axle holder.

- Push out the fork damper piston rod from the axle holder of the slider by pushing the fork damper.

Apply pressure to the fork damper and insert the piston base (6) or mechanic's stopper tool between the axle holder and fork center bolt lock nut (2).

Measure the thread length again.

Standard: 0.6 – 0.7 in (16 – 18 mm)

- Install the push rod (7) into the fork damper piston rod until it stops.
- Apply fork oil to new sealing washer (8) and O-ring (9) and install them to the fork center bolt (10).

Install the fork center bolt to the fork damper piston rod. Tighten the fork center bolt fully by hand.

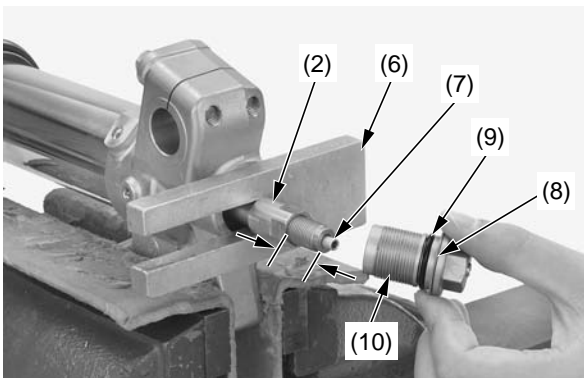

- (2) fork center bolt lock nut (8) sealing washer (new)
 (6) piston base (9) O-ring (new)
 (7) push rod (10) fork center bolt

- Measure the length of the fork center bolt lock nut (2) and fork center bolt (10) clearance. Standard: 0.04 – 0.14 in (1.0 – 3.5 mm)

If the clearance is out of specification, check the fork center bolt lock nut and fork center bolt installation.

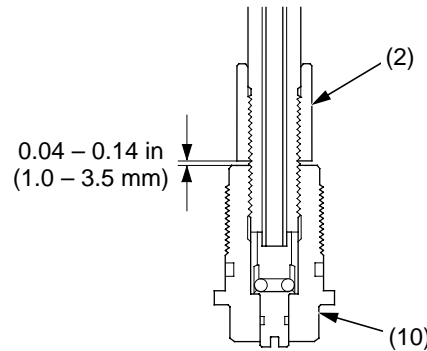

- (2) fork center bolt lock nut (10) fork center bolt

- Tighten the fork center bolt lock nut (2) to the fork center bolt (10) closely by hand. Tighten the fork center bolt lock nut to the specified torque using an open end wrench 9/16 in (15 mm):
 21 lbf-ft (29 N·m, 3.0 kgf·m)

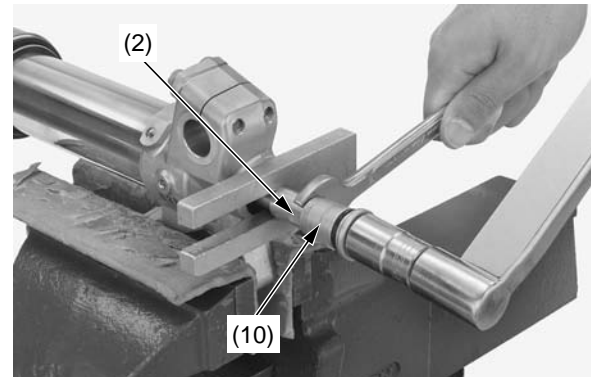

- (2) fork center bolt lock nut
 (10) fork center bolt

- Remove the piston base or mechanic's stopper tool while pushing the fork damper. Apply locking agent to the fork center bolt threads.

Install the fork center bolt (10) to the axle holder and tighten it to the specified torque:
 41 lbf-ft (55 N·m, 5.6 kgf·m)

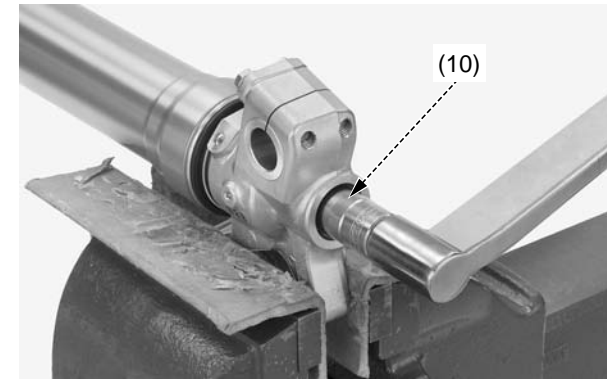

- (10) fork center bolt

- Measure the length between the axle holder and outer tube. Standard: 12.6 ± 0.1 in (319 ± 2 mm)
- Compare the length (11) at assembly and at disassembly. They should be the same length.

If the length at assembly is longer than at disassembly, check the fork center bolt and fork center bolt lock nut installation.

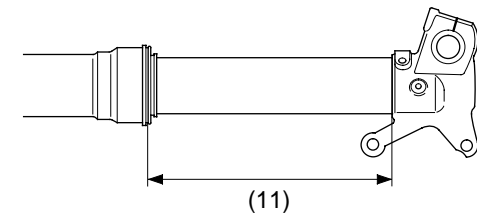

- (11) length

(cont'd)

Front Suspension Adjustments

13. Pour the recommended fork oil (12) into the fork assembly (1).

Recommended Oil:
KHL15-11 (KYB).

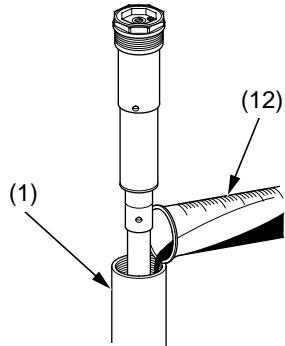

(1) fork assembly

(12) fork oil

Fork Oil Capacity:

Standard 26.27 lbf/in (4.6 N/mm) Fork Spring

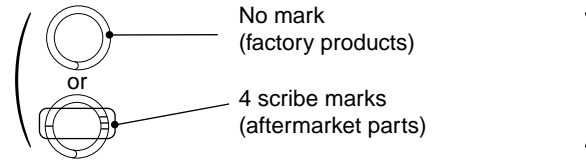

Standard oil capacity	12.0 US oz (355 cm ³)	
Maximum oil capacity	12.2 US oz (362 cm ³)	Slightly stiffer as it nears full compression.
Minimum oil capacity	10.3 US oz (305 cm ³)	Slightly softer as it nears full compression.

Optional Softer 25.12 lbf/in (4.4 N/mm) Fork Spring

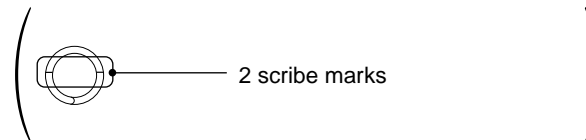

Standard oil capacity	11.9 US oz (352 cm ³)	
Maximum oil capacity	12.1 US oz (359 cm ³)	Slightly stiffer as it nears full compression.
Minimum oil capacity	10.2 US oz (303 cm ³)	Slightly softer as it nears full compression.

Optional Stiffer 27.41 lbf/in (4.8 N/mm) Fork Spring

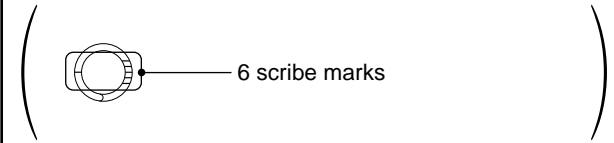

Standard oil capacity	11.8 US oz (350 cm ³)	
Maximum oil capacity	12.1 US oz (357 cm ³)	Slightly stiffer as it nears full compression.
Minimum oil capacity	10.1 US oz (300 cm ³)	Slightly softer as it nears full compression.

Be sure the oil capacity is the same in both fork legs.

Front Suspension Adjustments

14. Install a new O-ring (13) on the fork damper assembly (5). Apply the recommended fork oil to the O-ring.
15. Pull up the fork assembly (1) slowly and install the fork damper assembly (5) into the outer tube.

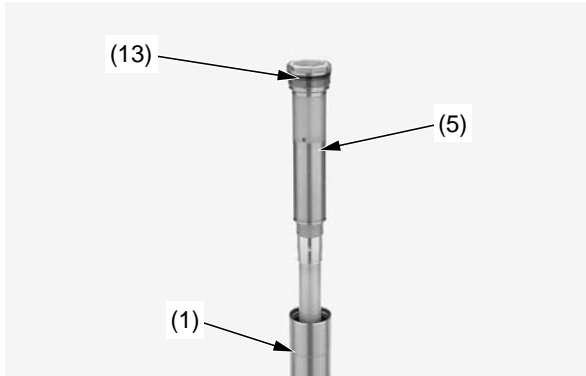

(1) fork assembly
(5) fork damper assembly
(13) O-ring

16. Insert both fork legs into the fork clamps. Tighten the fork bridge lower pinch bolts (14) to the specified torque:
15 lbf-ft (20 N·m, 2.0 kgf·m)

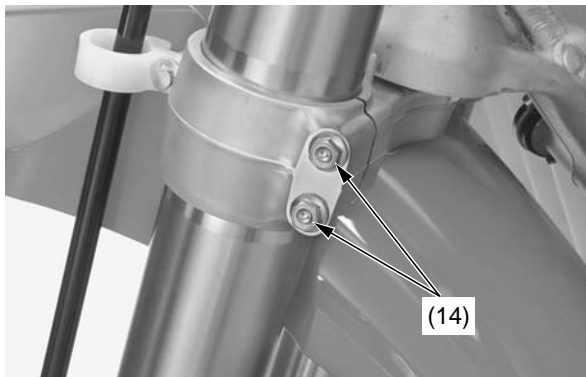

(14) fork bridge lower pinch bolts

17. Tighten the fork damper (15) to the specified torque using the lock nut wrench (16).
Actual:
22 lbf-ft (30 N·m, 3.1 kgf·m)
Torque wrench scale reading:
20 lbf-ft (27 N·m, 2.8 kgf·m), using a 20 in (50 cm) long deflecting beam type torque wrench.

• Lock nut wrench 070MA-MEN0100

When using the lock nut wrench, use a 20 in (50 cm) long deflecting beam type torque wrench. The lock nut wrench increases the torque wrench's leverage, so the torque wrench reading will be less than the torque actually applied to the fork damper.

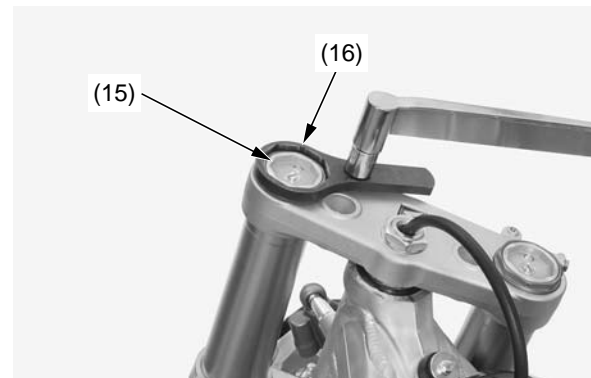

(15) fork damper (16) lock nut wrench

18. For ease of releasing air pressure after the forks are installed, loosen the fork bridge lower pinch bolts and position the outer tubes so that the fork air pressure release screws are in front of the compression damping adjusters. Align the top of the outer tube (17) with the top surface of the top bridge (18).

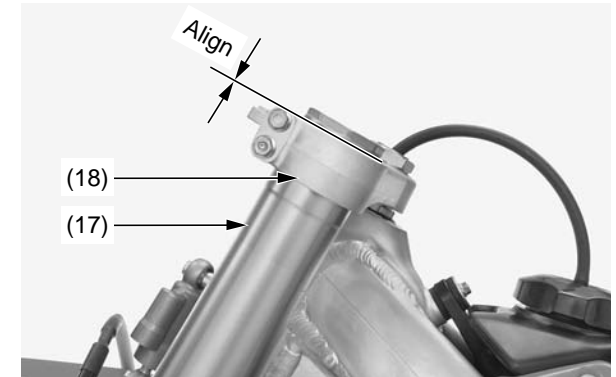

(17) outer tube (18) top bridge

19. Tighten the fork bridge lower pinch bolts (14) to the specified torque:
15 lbf-ft (20 N·m, 2.0 kgf·m)
20. Tighten the fork bridge upper pinch bolts (19) to the specified torque:
16 lbf-ft (22 N·m, 2.2 kgf·m)

NOTICE

Over-tightening the pinch bolts can deform the outer tubes. Deformed outer tubes must be replaced.

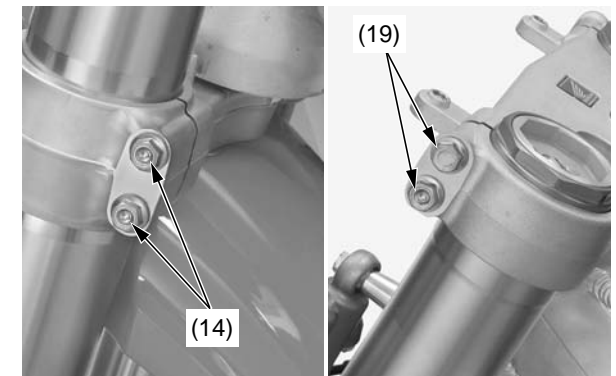

(14) fork bridge lower pinch bolts

(19) fork bridge upper pinch bolts

(cont'd)

Front Suspension Adjustments

21. Clean the threads of the fork protector socket bolts (20) and axle holder thoroughly. Apply locking agent to the bolt threads. Install the fork protectors (21), fork protector bolts. Tighten the fork protector socket bolts to the specified torque:
5.2 lbf-ft (7 N-m, 0.7 kgf-m)

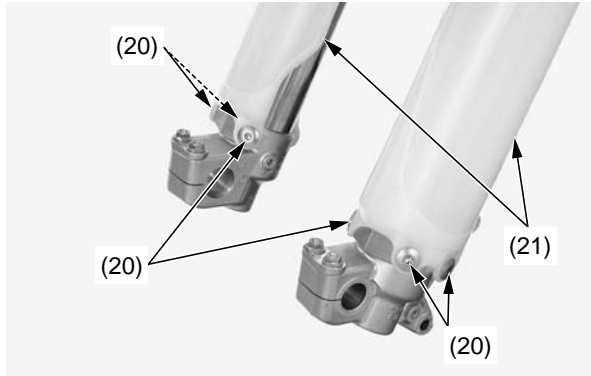

(20) fork protector socket bolts
(21) fork protectors

22. Align the brake caliper (22) and hose (23) with the left fork leg, making sure that the brake hose is not twisted. An improperly routed brake hose may rupture and cause a loss of braking efficiency.
23. Assemble the stay B (24), brake hose (23) and stay A (25). Install and tighten them to the left fork protector using the brake hose clamp bolts (26).

24. Clean the threads of the brake caliper mounting bolts (27) and brake caliper thoroughly. Apply locking agent to the bolt threads. Install the brake caliper (22) on the slider and tighten the brake caliper mounting bolts to the specified torque:
22 lbf-ft (30 N-m, 3.1 kgf-m)

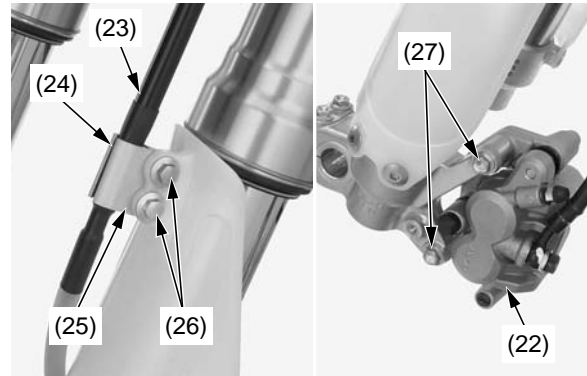

(22) brake caliper
(23) brake hose
(24) stay B
(25) stay A
(26) brake hose clamp bolts
(27) brake caliper mounting bolts

25. Clean the surfaces where the axle and axle clamps contact each other. Apply grease to each dust seal lips of the front wheel. Install the disc cover/collar (28) and right side collar (29) into the wheel hub.

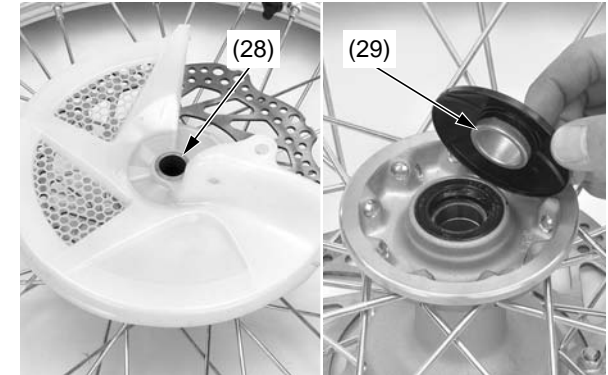

(28) disc cover/collar (29) right side collar

26. Install the front wheel between the fork legs while inserting the disc between the pads, being careful not to damage the pads.
27. Insert the front axle shaft through the forks and wheel hub from the right side. Make sure that the front axle shaft is seated firmly onto the left fork leg clamp inner surface. Tighten the front axle nut (30) to the specified torque:
65 lbf-ft (88 N-m, 9.0 kgf-m)
Tighten the left axle pinch bolts (31) to the specified torque:
15 lbf-ft (20 N-m, 2.0 kgf-m)

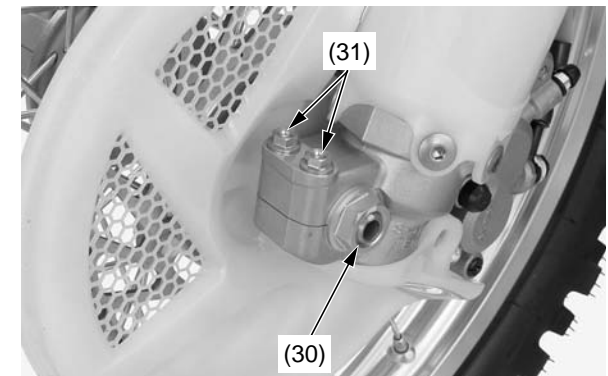

(30) front axle nut
(31) left axle pinch bolts

Front Suspension Adjustments

28. Install the handlebar (32), mounting rubbers, washers and handlebar lower holder nuts (33) and tighten the handlebar holder nuts to the specified torque:
32 lbf-ft (44 N·m, 4.5 kgf·m)



(32) handlebar
(33) mounting rubbers, washers and handlebar lower holder nuts

29. Install the number plate (page 100).

30. With the front brake applied, pump the fork up and down several times to seat the axle and check front brake operation.



31. While keeping the forks parallel, alternately tighten the right axle pinch bolts (34) to the specified torque:
15 lbf-ft (20 N·m, 2.0 kgf·m)

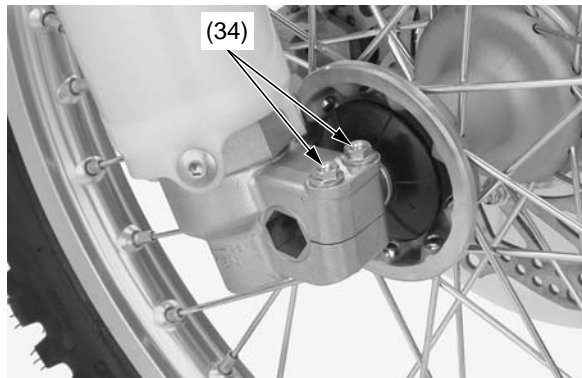

(34) right axle pinch bolts

NOTICE

To avoid damage when torquing the axle pinch bolts, be sure the axle is seated firmly onto the left fork leg clamp inner surface.

32. Clean the threads of the disc cover socket bolt (35) and apply locking agent to the bolt threads. Install and tighten the disc cover socket bolt to the specified torque:
10 lbf-ft (13 N·m, 1.3 kgf·m)

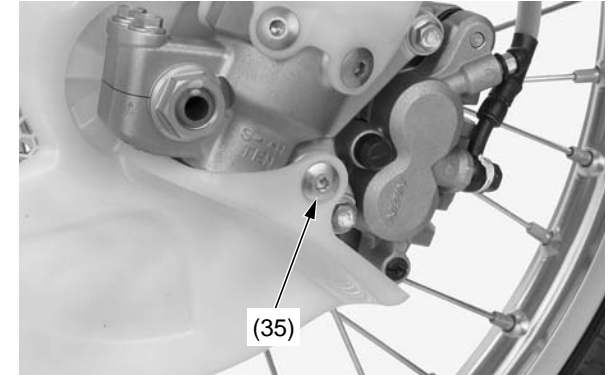

(35) disc cover socket bolt

33. Turn the rebound damping (36) and compression damping (37) adjuster screws back to their original settings.

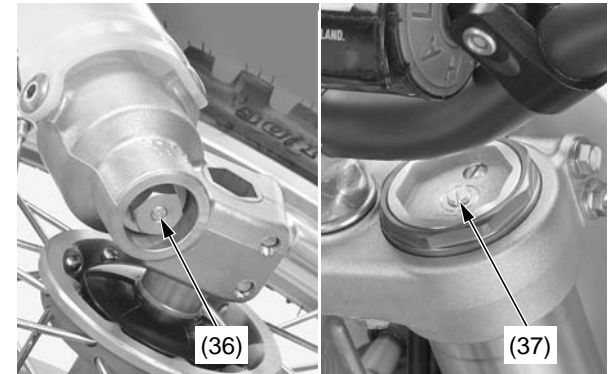

(36) rebound damping adjuster
(37) compression damping adjuster

Rear Suspension Adjustments

The rear suspension can be adjusted for the rider's weight and riding conditions by changing the spring pre-load and the rebound and compression damping.

The rear suspension assembly includes a damper unit that contains high pressure nitrogen gas. Do not attempt to disassemble, service, or dispose of the damper; see your Honda dealer. The instructions found in this owner's manual are limited to adjustments of the shock assembly only.

Puncture or exposure to flame may also result in an explosion, causing serious injury. Service or disposal should only be done by your Honda dealer or a qualified mechanic, equipped with the proper tools, safety equipment and an official Honda Service Manual.

If your CRF is new, put enough part-throttle break-in time (about 1 hour) on it to ensure that the suspension has worked in.

Rear Suspension Spring Pre-Load

Pre-load should be adjusted when the engine is cold because it is necessary to remove the muffler.

An optional pin spanner is available for turning the shock spring lock nut and adjusting nut to adjust spring pre-load.

1. Place your CRF on an optional workstand or equivalent support with the rear wheel off the ground.
2. Remove the subframe (page 36).

3. Check that the spring pre-load is adjusted to the standard length. Adjust as necessary by loosening the shock spring lock nut (1) and turning the adjusting nut (2).

Each complete turn of the adjuster nut changes the spring length by 0.06 in (1.5 mm).

4. After adjustment, hold the adjusting nut and tighten the shock spring lock nut to the specified torque:

21 lbf·ft (28 N·m, 2.9 kgf·m)

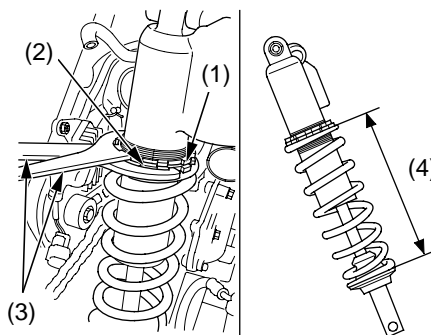

- (1) shock spring lock nut (3) pin spanners
(2) adjusting nut (4) spring length

To increase spring pre-load

Loosen the shock spring lock nut with the optional pin spanners (3) and turn the adjusting nut to shorten the spring length (4). Do not shorten to less than:

Standard spring (308.3 lbf/in (54 N/mm)):

9.45 in (240.0 mm)

Optional softer spring (296.9 lbf/in (52 N/mm)):

9.41 in (239.0 mm)

Optional stiffer spring (319.8 lbf/in (56 N/mm)):

9.37 in (238.0 mm)

To decrease spring pre-load

Loosen the shock spring lock nut with the optional pin spanners (3) and turn the adjusting nut to increase the spring length (4). Do not increase to more than:

9.86 in (250.5 mm)

Each turn of the adjuster changes spring length and spring pre-load. One turn equals: spring length/spring pre-load:

0.06 in (1.5 mm)/18.21 lbf (81 N)

Pin spanners should be used for turning the shock spring lock nut and adjusting nut. See page 152 for optional pin spanners.

Spring pre-load length (Standard spring)

Standard: 9.82 in (249.5 mm)

Max. : 9.86 in (250.5 mm)

Min. : 9.45 in (240.0 mm)

Rear Suspension Damping

Compression Damping

Compression damping may be adjusted in two stages with separate adjusters.

The high speed damping adjuster (1) is effective when damping adjustment is desired for high speed operation. The low speed damping adjuster (2) should be used when damping adjustment is desired at relatively low speeds.

- Both the high and low speed compression damping can be increased by turning the appropriate adjuster clockwise.
- Adjust the high speed compression adjuster in 1/12 turn increments.
- Be sure the low speed compression adjuster is firmly located in a detent, and not between positions.

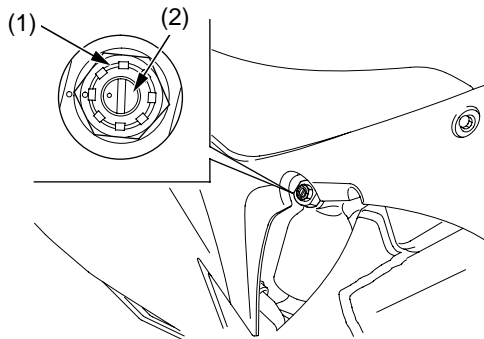

- (1) high speed damping adjuster
(2) low speed damping adjuster

High Speed Damping:

The high speed damping can be adjusted by turning the hexagonal portion of the compression adjuster.

To adjust to the standard position:

1. Turn the adjuster clockwise until it will no longer turn (lightly seats). This is the full hard setting.
2. Turn the adjuster counterclockwise 1 1/12 – 1 5/12 turns and the punch marks are aligned.

Low Speed Damping:

The low speed damping can be adjusted by turning the center screw of the compression adjuster.

The low speed compression adjuster has 18 positions or more.

Turning the adjuster one full turn clockwise advances the adjuster 4 positions.

To adjust to the standard position:

1. Turn the adjuster clockwise until it will no longer turn (lightly seat). This is the full hard setting.
2. Turn the adjuster counterclockwise 11 – 15 clicks and the punch marks are aligned.

Rebound Damping

The rebound damping adjuster (3) is located at the lower end of the rear shock absorber.

It has 20 positions or more. Turning the adjuster one full turn advances the adjuster 6 positions.

- Rebound damping can be increased by turning the adjuster clockwise.
- Be sure that the rebound adjuster is firmly located in a detent, and not between positions.

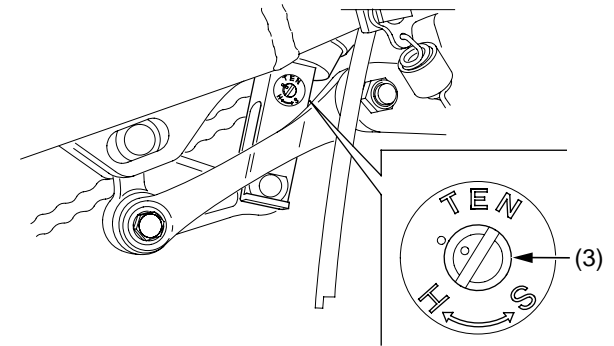

(3) rebound damping adjuster

To adjust to the standard position:

1. Turn the adjuster clockwise until it will no longer turn (lightly seat). This is the full hard position.
2. Turn the adjuster counterclockwise 11 – 15 clicks with the punch marks on the adjuster and the rear shock absorber aligned.

Rear Suspension Adjustments

Rear Suspension Race Sag

Setting the proper race sag (ride height) is very important for competition use.

Race sag refers to the amount of rear wheel travel used by your CRF at rest, ready to ride, with you on the seat. As a general rule of thumb, the race sag dimension should be about one-third of the maximum travel.

On your CRF, ride height is changed by adjusting the rear suspension spring pre-load.

Spring Pre-load & Race Sag Adjustment

The following adjustment procedure establishes the correct starting point for any suspension tuning — the proper rear suspension spring pre-load adjustment for your specific needs.

Your CRF should be at normal racing weight, including fuel, oil and coolant. You should be wearing all your normal protective apparel. You will need two helpers.

To calculate the proper adjustment, it is necessary to measure between two fixed points — from the center of the rear fender mounting bolt to the center of the chain adjuster lock nut as illustrated here — for three different situations:

unloaded: motorcycle on an optional workstand with rear suspension fully extended, no rider.

loaded with rider: motorcycle on ground, with rider.

loaded without rider: motorcycle on ground, without rider

1. Support your CRF on an optional workstand with the rear wheel off the ground.
2. Measure the *unloaded* dimension.

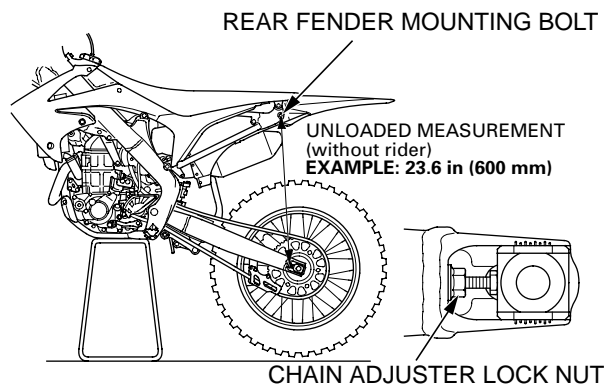

3. Measure the *loaded with rider* dimension. Remove the workstand. With two helpers available, sit as far forward as possible on your CRF's seat, wearing your riding apparel. Ask one helper to steady your CRF perfectly upright so you can put both feet on the pegs. Bounce your weight on the seat a couple of times to help the suspension overcome any situation and settle to a good reference point.

Ask the other helper to measure the *loaded with rider* dimension.

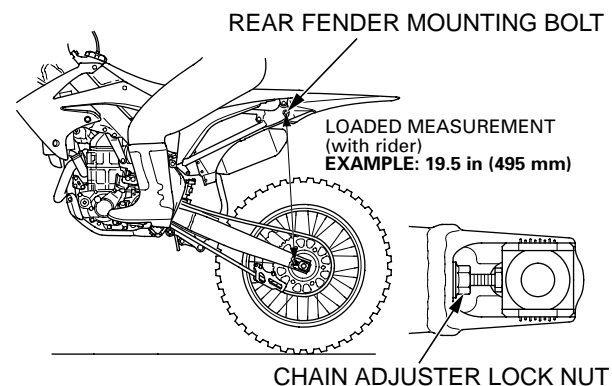

Example:

Unloaded	= 23.6 in (600 mm)
– Loaded	= 19.5 in (495 mm)
Race Sag	= 4.1 in (105 mm)

4. Calculate the *race sag* dimension. To do this, subtract the *loaded with rider* dimension (step 3) from the *unloaded* dimension (step 2).
Standard Race Sag: 4.1 in (105 mm)

Adjust spring pre-load as necessary to obtain the desired handling results.

Decreasing the race sag dimension (example: 3.7 in, 95 mm) improves turning ability for tight terrain at the cost of slightly reduced straight line stability.

Increasing the race sag dimension (example: 4.5 in, 115 mm) may improve stability on faster terrain with less turns, but will reduce turning performance slightly and may upset the balance between the front and rear suspension, producing a harsher ride. This will happen if the adjustment shifts the effective wheel travel toward the more progressive end of its range.

5. Measure the *loaded without rider* dimension. Do this with your CRF set at the standard race sag.

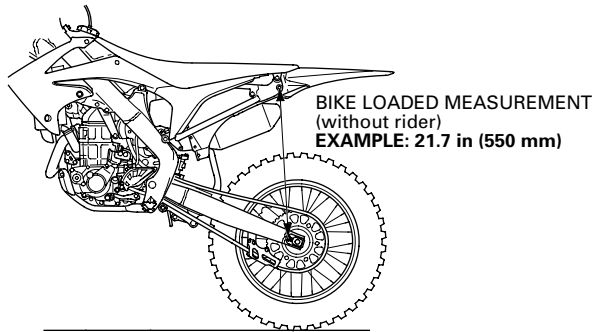

Example:
Unloaded = 23.6 in (600 mm)
– Loaded = 21.7 in (550 mm)
Sag = 2.0 in (50 mm)
(Without Rider)

6. Calculate the *free sag* dimension. To do this, subtract the *loaded without rider* dimension (step 5) from the *unloaded* dimension (step 2). Free sag indicates the distance your rear suspension should sag from the weight of the sprung portion of your CRF. With the spring pre-load set to obtain the proper race sag, the rear suspension should sag 0.4 to 1.0 in (10 to 25 mm). If the rear of your CRF sags less than 0.4 in (10 mm) from its own weight, the spring is too stiff for your weight. It is not compressed enough, reduce the spring pre-load or replace the shock spring with a softer spring.

Spring Rates

If you are lighter or heavier than the average rider and cannot set the proper ride height without altering the correct spring pre-load, consider an aftermarket rear shock spring.

A spring that is too soft for your weight forces you to add excessive spring pre-load to get the right race sag and, as a result, the rear end of the motorcycle is raised. This can cause the rear wheel to unload too much in the air and top out as travel rebounds. The rear end may top out from light braking, or kick sideways over lips and square-edged terrain. It may even top-out when you dismount your CRF.

Because of the great absorption quality of the shock bumper rubber, it may be difficult for you to notice when your CRF's suspension is bottoming. Some riders may think the damping or perhaps the leverage ratio is too harsh. In reality, the problem is most likely insufficient spring pre-load or a spring that is too soft. Either situation prevents utilizing the full travel.

Keep in mind that a properly adjusted suspension system may bottom slightly every few minutes at full speed. Adjusting the suspension to avoid this occasional bottoming may cost more in overall suspension performance than it is worth.

A spring that is too stiff for your weight will not allow the rear tire to hook up under acceleration and will pass more bumps on to you.

Suspension Adjustments for Track Conditions

Soft Surface

On soft ground, sand, and especially mud, consider increasing compression damping front and rear.

Sand often requires a bit more rebound damping to minimize rear end kick. Although sand bumps are usually larger, there's more distance between them, giving the shock more time to recover.

You may want a little bit stiffer front suspension for sand tracks to help keep the front end up and improve straight-line stability.

In a muddy event, stiffer aftermarket springs front and rear may help, especially if you are heavier than the average rider. Your CRF may be under-sprung because of the added weight of the clinging mud. This additional weight may compress the suspension too much and affect traction.

Hard Surface

For a fast, hard track with no large jumps, you can probably run the same spring as normal, but run softer damping both ways-compression and rebound. If you run softer rebound damping, the wheel will follow the rough ground and small bumps much better, and you will hook up better. With a lot of rebound damping, the wheel returns very slowly and doesn't contact the ground quickly enough after each bump. The result is a loss of traction and slower lap times.

Suspension Adjustment Guidelines

Follow the procedures described below to accurately adjust your CRF, using the methods described on pages 108 – 126. Remember to make all adjustments in one-click or 1/12 turn increments. Test ride after each adjustment.

Front Suspension Adjustment Adjustments for Type of Track

Hard-surfaced track	Begin with the standard setting. If the suspension is too stiff/soft, adjust according to the chart below.
Sand track	Adjust to a stiffer position. Example: – Turn the compression damping adjuster to a stiffer position. – Install an optional stiff spring. (Adjust compression damping to a softer position and rebound damping to a stiffer position at this time.)
Mud track	Adjust to a stiffer position because mud build-up increases your CRF's weight. Example: – Turn the compression damping adjuster to a stiffer setting. – Install an optional stiff spring.

Adjustments for Too Soft/Stiff Damping

	Symptom	Action
Soft suspension	Initial travel too soft: <ul style="list-style-type: none"> • Steering is too quick. • Front end darts while cornering or riding in a straight line. 	<ul style="list-style-type: none"> – Test stiffer compression damping adjustments in one-click increments. – Test stiffer rebound damping in one-click increments.
	Middle travel too soft: <ul style="list-style-type: none"> • Front end dives when cornering. 	If suspension isn't stiff in initial travel: <ul style="list-style-type: none"> – Test stiffer compression damping adjustments in one-click increments. If initial travel becomes stiff because of the above adjustment: <ul style="list-style-type: none"> – Reduce the rebound damping in one-click increments. – Test softer compression damping adjustments in one-click increments. If that doesn't solve the problem, install an optional stiff spring.
	Final travel too soft: <ul style="list-style-type: none"> • Bottoms on landings. • Bottoms on large bumps, especially downhill bumps. 	If initial and middle travel aren't stiff: <ul style="list-style-type: none"> – Test stiffer compression damping adjustments in one-click increments. If initial and middle travel are stiff: <ul style="list-style-type: none"> – Install an optional stiff spring. If initial travel is stiff after installing an optional stiff spring: <ul style="list-style-type: none"> – Test softer compression damping adjustments in one-click increments. If initial travel is still soft after installing an optional stiff spring: <ul style="list-style-type: none"> – Test stiffer compression damping adjustments in one-click increments. If final travel is still soft after installing an optional stiff spring: <ul style="list-style-type: none"> – Increase the fork oil capacity in increments of 0.2 US oz (5 cm³).
	Entire travel too soft: <ul style="list-style-type: none"> • Front end shakes. • Fork bottoms over any type of terrain. 	<ul style="list-style-type: none"> – Install an optional stiff spring. – Test stiffer compression damping adjustments in one-click increments. – Increase rebound damping in one-click increments.

Suspension Adjustment Guidelines

	Symptom	Action
Stiff suspension	<p>Initial travel too stiff:</p> <ul style="list-style-type: none"> • Stiff on small bumps while riding at full throttle in a straight line. • Stiff on small cornering bumps. • Front end wanders while riding at full throttle in a straight line. 	<ul style="list-style-type: none"> – Test softer compression damping adjustments in one-click increments. – Reduce the rebound damping adjustments in one-click increments. – Check for dirt in the dust seals. Check the fork oil for any contamination. If the front end dives while cornering, reduce the rebound damping in one click increments. If that doesn't solve the problem, install an optional stiff spring. – If the stiff spring makes the suspension too stiff over the full range of travel: test softer compression damping adjustments in one-click increments until the desired compression damping for initial travel is obtained.
	<p>Middle travel too stiff:</p> <ul style="list-style-type: none"> • Stiff on bumps when cornering. • Front end wanders when cornering. • Stiff suspension on bumps, especially downhill bumps. • While braking, front end dives during initial travel, then feels stiff. 	<p>If initial travel isn't stiff:</p> <ul style="list-style-type: none"> – Test stiffer compression damping adjustments in one-click increments. (This should produce smooth fork action from initial to middle travel.) <p>If initial and middle travel is stiff:</p> <ul style="list-style-type: none"> – Test softer compression damping adjustments in one-click increments. – Reduce the rebound damping in one-click increments.
	<p>Final travel too stiff:</p> <ul style="list-style-type: none"> • Doesn't bottom on landings, but feels stiff. • Stiff on large bumps, especially downhill bumps. • Stiff on large bumps when cornering. 	<p>If initial and middle travel aren't stiff:</p> <ul style="list-style-type: none"> – Test stiffer compression damping adjustments in one-click increments. (This should produce smooth fork action from initial to middle travel.) <p>If final travel is still stiff after the above adjustment, or if initial and middle travel becomes stiff:</p> <ul style="list-style-type: none"> – Install an optional soft spring. – Test softer compression damping adjustments in one-click increments. <p>If the entire travel feels stiff after the above adjustment:</p> <ul style="list-style-type: none"> – Test softer compression damping adjustments in one-click increments until the desired initial travel compression damping is obtained. – Lower the oil capacity by 0.2 US oz (5 cm³).
	<p>Entire travel too stiff:</p> <ul style="list-style-type: none"> • Stiff suspension on any type of terrain. 	<ul style="list-style-type: none"> – Test softer compression damping adjustments in one-click increments. – Reduce the rebound damping in one-click increments. – Lower the oil capacity by 0.2 US oz (5 cm³).

Suspension Adjustment Guidelines

Rear Suspension Adjustment Adjustments for Type of Track

Hard-surfaced track	Begin with the standard settings. If the suspension is too stiff/soft, adjust according to the chart below.
Sand track	Lower the rear end (to improve front wheel stability) by increasing Race Sag (reduce spring pre-load). Example: – Turn the compression damping adjuster and, especially, rebound damping adjuster to a stiffer setting. – Increase standard Race Sag (+0.2 to 0.4 in/5 to 10 mm).
Mud track	Adjust to a stiffer position because mud build-up increases your CRF's weight. Example: – Adjust the compression and rebound damping adjusters to stiffer settings. – Install an optional stiff spring. – Reduce standard Race Sag (–0.2 to –0.4 in/–5 to –10 mm).

Symptoms and Adjustment

- Always begin with the standard settings.
- Turn the low speed compression and rebound adjusters in one-click increments, and the high speed compression adjuster in 1/12 turn increments at a time. Adjusting two or more clicks or turns at a time may cause you to pass over the best adjustment. Test ride after each adjustment.
- If, after setting, the suspension feels unusual, find the corresponding symptom in the table and test stiffer or softer compression and/or rebound damping adjustments until the correct settings are obtained as described.

	Symptom	Action
Stiff suspension	Suspension feels stiff on small bumps	1. Test softer low speed compression adjustment. 2. If it still feels stiff, further test softer low and high speed compression adjustments simultaneously.
	Suspension feels stiff on large bumps	1. Test softer high speed compression adjustment. 2. If it still feels stiff, further test softer low and high speed compression adjustments simultaneously.
	Entire travel too stiff	1. Test softer high and low speed compression adjustments and rebound adjustment simultaneously. 2. If it still feels stiff, replace the spring with a softer spring (optional) and begin with the standard settings to softer settings.
Soft suspension	Entire travel too soft	1. Test stiffer high and low speed compression adjustments simultaneously. 2. If it still feels soft, replace the spring with a stiffer spring (optional) and begin with the standard settings to stiffer setting.
	Rear end sways	1. Test stiffer high and low speed compression adjustments and rebound adjustment to stiffer settings simultaneously.
Suspension bottoms	Suspension bottoms at landing after jumping	1. Test stiffer high speed compression adjustment. 2. If it still bottoms, test stiffer high and low speed compression adjustments, and replace the spring with a stiffer spring (optional) if necessary.
	Suspension bottoms after landing	1. Test stiffer low speed compression adjustment. 2. If it still bottoms, test stiffer high and low speed compression adjustments, and replace the spring with a stiffer spring (optional) if necessary.
	Suspension bottoms after end of continuous bumps	1. Test softer rebound dumping adjustment. 2. If it still bottoms, test stiffer high and low speed compression adjustments and softer rebound damping adjustment, and replace the spring with a stiffer spring (optional) if necessary.

Tuning Tips

An optional PGM-FI setting tool can change the ignition timing and amount of the fuel injection (page 153).

Be sure to observe the PGM-FI setting by checking the spark plug.

Spark Plug Reading

Refer to *Spark Plug* on page 63.

The following procedure is recommended. You may not get an accurate reading if you simply turn off the engine and pull the plug for inspection.

Use a new spark plug. Inspect the plug before installing it.

NOTICE

Using spark plugs with an improper heat range or incorrect reach can cause engine damage.

Ride for 10 – 15 minutes before taking a plug reading. A new plug will not color immediately.

Before removing the spark plug, clean the spark plug area thoroughly to prevent dirt from entering the cylinder.

To obtain an accurate reading of a new spark plug:

1. Accelerate at full throttle on a straight.
2. Depress and hold the engine stop button and pull the clutch lever in.
3. Coast to a stop.
4. Remove the spark plug.
5. Use a magnifying glass to inspect the spark plug. The porcelain insulator (1) around the center electrode (2) should appear clean and colorless with a gray ring around the center electrode where it exits the porcelain. Light gray or white color streaks the porcelain insulator and center electrode indicate lean air-fuel mixture. Wet or black sooty streaks on the porcelain indicate rich air-fuel mixture.

NOTICE

An improperly tightened spark plug can damage the engine. If a plug is too loose, a piston may be damaged. If a plug is too tight, the threads may be damaged.

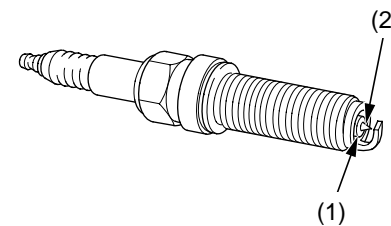

(1) porcelain insulator (2) center electrode

Spark Plug Coloring Guidelines

Condition	Spark Plug Appearance	Mixture
Normal	Dark brown to light tan color with dry electrode	correct
Overheating (Lean)	Light gray or white color	lean
Wet (Rich)	Wet or sooty	rich

Remember that in addition to improper air-fuel mixture:

- A lean condition can be caused by air leaks in the inlet tract or exhaust system, the passage of too much air because of the use of the wrong air cleaner, use of a less-restrictive aftermarket exhaust system.
- A rich condition can be caused by a plugged or dirty air cleaner, use of a more-restrictive aftermarket exhaust system, or excessive oil on the air cleaner. Excessive smoking will occur.

The steering damper can be adjusted for riding conditions by using following method:

- **Damping** – Turning the steering damper adjuster adjusts how quickly the steering damper compress or extend.

Steering Damper Damping

The steering damper adjuster (1) has 13 positions or more. Turning the adjuster one full turn clockwise advances the adjuster six positions. To adjust the adjuster to the standard setting, proceed as follows:

Turn the adjuster clockwise until it will no longer turn (lightly seats). This is the full hard position. The adjuster is set in the standard position when the adjuster is turned counterclockwise 9 – 12 clicks.

Damping can be increased by turning the adjuster clockwise.

NOTICE

Always start with full hard when adjusting damping.

Do not turn the adjuster more than the given positions or the adjuster may be damaged.

Be sure that the steering damper adjuster is firmly located in a detent, and not between positions.

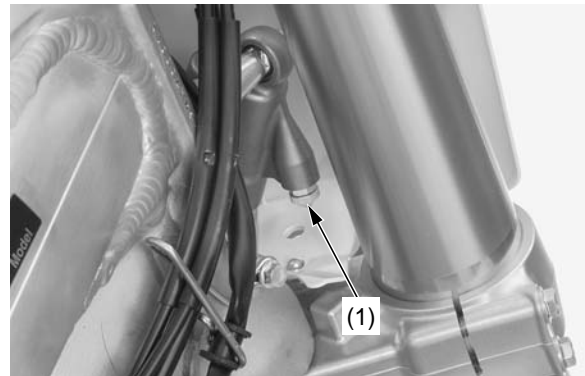

(1) steering damper adjuster

Steering Damper Adjustment Guidelines

Follow the procedures described below to accurately adjust your CRF, using the methods described on this page.

Symptoms and Adjustment

- Always begin with the standard settings.
- Turn the steering damper adjuster in one-click increments at a time. Adjusting two or more clicks at a time may cause you to pass over the best adjustment. Test ride after each adjustment.

Symptom	Action
Steering is wobbling on large bumps	Adjust the steering damper adjuster to a stiffer setting.
Steering is wobbling on a sand track	Adjust the steering damper adjuster to a stiffer setting.
Steering is heavy when cornering	Adjust the steering damper adjuster to a softer setting.

The following suggestions may improve a specific concern. Subtle changes in overall handling may also be noted.

Rear End

If you have a problem with rear wheel traction, raise the rear end of your CRF by increasing the rear suspension spring pre-load. Instead of running 4.1 in (105 mm) of sag, you can run 3.7 in (95 mm) so the rear of the motorcycle will sit a little higher. This should produce more traction because of the change to the swingarm and location of your CRF's center of gravity.

If you have a problem with the steering head shaking when you use the front brake hard or if your CRF wants to turn too quickly, lower the rear of the motorcycle by reducing the rear suspension spring pre-load. This will increase fork rake and trail and should improve stability in a straight line. The effective suspension travel will be transferred toward the firmer end of wheel travel.

Keep the race sag adjustment (page 124) in the 3.7 – 4.5 in (95 – 115 mm) range.

Fork Height/Angle

The position of the fork tube in the clamp is not adjustable. Align the top of the outer tube (not the top of the fork cap) with the top of the top bridge.

Standard Position

The standard position (1) align the top of the outer tube (2) (not the top of the fork cap) with the top of the top bridge (3).

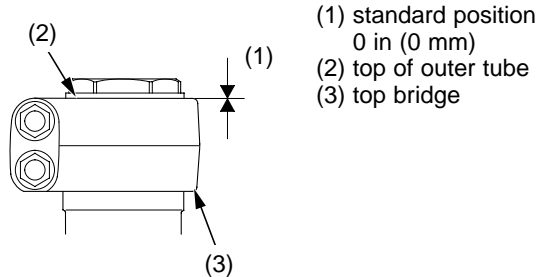

Wheelbase

Adjusting your CRF's wheelbase can offer subtle changes in overall handling. You may adjust wheelbase by adding or removing links on the drive chain. If you change the wheelbase, be sure to recheck race sag and adjust, if necessary.

In the past, a general rule was lengthen the wheelbase to add straight line stability, shorten the wheelbase to improve turning. However, we suggest you do not lengthen the wheelbase of your CRF unless you are racing on a track with more fast sections than normal.

As a general recommendation, keep the wheelbase as short as possible. This positions the wheels closer together, improves turning response, increases weighting (traction) on the rear wheel, and lightens weighting on the front wheel.

With your CRF, you will probably find that the standard setting or a shorter wheelbase will offer more overall benefits.

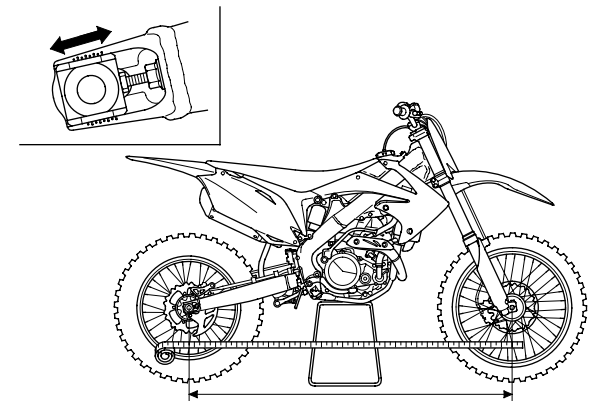

Gearing

You can “adjust” the power delivery of the standard engine to suit track conditions by changing gearing. This allows you to utilize a different portion of the engine’s power range at a given throttle setting. New gearing may provide the change you are looking for without the need to consider further modifications.

The portion of your engine’s power range you use can be adjusted by changing the final drive ratio with different sized rear sprockets. Gearing changes allow you to more closely match the type of terrain and the available traction.

Normally, a change of one tooth on the driven sprocket will be sufficient.

There is a choice of both higher and lower final drive ratios with two optional driven sprockets. Like the optional springs, these sprockets are listed in the Optional Parts List section of this manual (page 152).

Unless you have the required mechanical know-how, tools, and an official Honda Service Manual, sprocket changing should be done by your Honda dealer.

Higher Gearing (less driven sprocket teeth)

- increases top speed in each gear (provided the engine will pull the higher gearing)
- reduces frequency of shifting (wider gear ratios)
- reduces engine rpm at a given throttle setting or ground speed (which may allow better rear wheel traction on slippery or loose terrain)

However:

- the engine may not pull the higher gearing
- the spacing between gears may be too wide
- engine rpm may be too low

Lower Gearing (more rear sprocket teeth)

- decrease top speed in each gear
- increases frequency of shifting (narrower gear ratios)
- increases engine rpm at a given throttle setting or ground speed (which may provide more power-to-the-ground on good traction surfaces)

However:

- spacing between gears may be too narrow
- engine rpm may be too high

Some tracks may be watered heavily prior to the first race, then lightly or not at all during the day. This results in a track surface that is slippery during the first few races, then changes from good to great and back to good and possibly ends the day with a slick rock-hard consistency.

Ideally, your gearing should be adjusted to suit all these conditions.

- Wet and slippery or sandy conditions: use a higher gear (less teeth) to keep engine rpm down, and avoid unwanted wheelspin. The engine may bog in certain corners so you’ll need to slip the clutch to compensate; downshifting may be too drastic a change in speed.
- Average conditions: use the standard sprocket.
- Hard (but not slippery) track conditions: use lower gearing (more teeth) to keep the engine rpm high where the engine produces the most power. This may require an extra upshift on certain sections or perhaps you can just rev it out a bit longer.

For tight tracks, consider lower gearing to avoid having to slip the clutch frequently. Repeated fanning or pulling of the clutch lever in a turn to raise engine rpm may eventually damage the clutch system.

A gearing change may help for riding in sand, where you want to keep the front end light so it can float from the peak of one sand whoop to the next. Generally, with higher gearing, it is easier to maintain that perfect attitude (maximum rear wheel traction and a light front end) because you remain in the powerband longer in each gear. The higher gearing allows you to steer more efficiently with throttle control and body English.

If you are riding a track with sections where you choose to over-rev the engine temporarily rather than shifting up, higher gearing might help.

Sometimes you have to sacrifice performance on one section of the track to gain a better overall time. Your goal is the fastest overall lap time, even if the cost is some sections where the gearing feels wrong.

If you decide to try a gearing change, have someone check your times with a stopwatch (before and after the change) to get an accurate appraisal of the change. “Seat-of-the-pants” feelings can’t be trusted. Eliminating wheelspin with a gearing change can make you feel like you’re going slower when, in reality, you’ve decreased your time by increasing your speed with better traction.

These gearing recommendations should be evaluated by considering your ability, your riding style, and the track.

Choosing the correct tire tread pattern and rubber compound can affect your placing in competition. The tires on your CRF offer a “happy medium” for the variety of soil conditions the majority of riders are likely to encounter.

Experienced competitors often switch to tires developed for specific terrain conditions. If you do switch, stay with the factory recommended sizes. Other tires may affect handling or acceleration.

Be aware that tire sizes (width and aspect ratio) do vary from manufacturer to manufacturer or even among tires made by the same manufacturer. Variations in tires, especially the sidewall profile, can change the attitude of your CRF and its handling. Tire variations that raise or lower the rear of your CRF have a more significant effect on handling than variations in front tires which, generally, don't vary as much. Often, you can see or feel the change in tire size. Another way to check is to measure the rolling circumference of the old and new tires. A higher profile tire will have a larger rolling circumference.

If you do switch to tires designed for special terrain use, remember they will be less acceptable in other circumstances. For example, an aggressive mud tire will give excellent grip on wet, loamy terrain, but less impressive grip on a hard surface.

If you choose a tire with a sticky compound for added traction, remember that it may transfer additional loads to the transmission because it grips so well, especially when riding in situations that normally place unusual demands on the transmission.

Complete consumer information can be obtained from the various tire manufacturer representatives and dealers.

Some general recommendations for specific terrain follow:

Hard, Slick Soil

Use tires with many relatively short knobs that are close together in order to obtain the largest possible contact patch on the surface. The rubber compound needs to be softer for hard ground in order to hook up, but not so soft that the knobs roll over easily and affect holding a straight line. These tires tend to wear more quickly than standard tires because of the combination of soft rubber and hard terrain.

Muddy Soil

Use a more open tread pattern to avoid clogging. For these conditions, the relatively long knobs will probably be made from a harder rubber compound to reduce any tendency to bend back under acceleration or wear quickly.

Loose, Sandy Soil

Use a tire that is similar in construction to those needed for tacky soil and mud, but with a few more knobs.

Personal Fit Adjustments

The following suggestions may make your ride both more comfortable and more responsive to your control input.

Control Positioning

- Position the control levers so that you can use them comfortably when seated and standing.
- Adjust the mounting bolt torque of the clutch and front brake lever assemblies so that they can rotate on the handlebar in a fall. If an assembly does not rotate, it may bend or break a control lever. Make sure that the bolts are torqued securely enough to prevent slippage during normal operation.

Apply Pro Honda Hondalock or an equivalent to the threads of these bolts prior to adjustment to help ensure the correct torque is retained. Tighten the top bolts first.

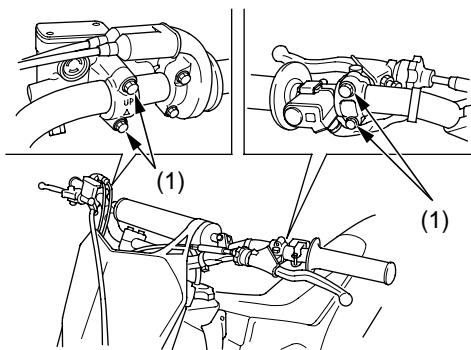

(1) control lever mounting bolts

As an alternative, consider wrapping the handlebar area under the control assemblies with Teflon tape. Then tighten the assemblies to their normal torque. Upon impact, the fully-tightened assemblies should rotate on the Teflon tape.

- Position the shift lever and rear brake pedal so they are close to your boot for rapid access, but not so close that either is depressed when sitting or standing comfortably on your CRF.

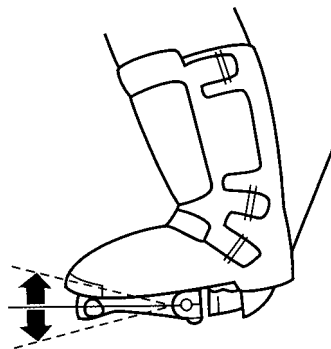

Handlebar Position, Width & Shape

- Position the handlebar so that both gripping the bar and operating the controls is comfortable while both seated and standing, while riding straight ahead and turning. Tighten the forward handlebar upper holder bolts first.
- The handlebar position may be moved forward either 0.1 in (3 mm) (using optional handlebar lower holders) or 0.2 in (6 mm) (by rotating the standard holders 180 degrees). Refer to an official Honda Service Manual for installation instructions. Be sure to check control cable and wiring harness routing after the adjustment.

- Handlebar width can be trimmed with a hacksaw to better suit your particular shoulder width and riding preference. Think this through carefully and cut off just a small amount at a time from both sides equally. It is obviously much easier to make the handlebar narrower than it is to add material.

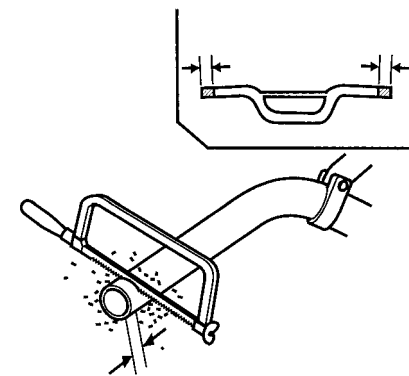

- Chamfer the edges to remove burrs and other irregularities or roughness after sawing the handlebar.
- An alternate handlebar shape, through varying rise or rearward sweep dimensions, will provide further adjustment to riding position and may better suit your particular body size or riding style. Each of the ergonomic dimensions of the machine were determined to suit the greatest possible number of riders based on an average size rider.

Here's helpful advice on how to transport and store your CRF, as well as three troubleshooting flow charts.

Transporting Your Motorcycle138
Storing Your Honda.....139
 Preparation for Storage139
 Removal from Storage.....139
You & the Environment140
Troubleshooting.....141

Transporting Your Motorcycle

If you use a truck or motorcycle trailer to transport your CRF, we recommend that you follow these guidelines:

- Use a loading ramp.
- Relieve the fuel pressure (page 41) and drain the fuel from the fuel tank into an approved gasoline container.
- Secure the motorcycle in an upright position, using motorcycle tie-down straps. Avoid using rope, which can loosen and allow the motorcycle to fall over.

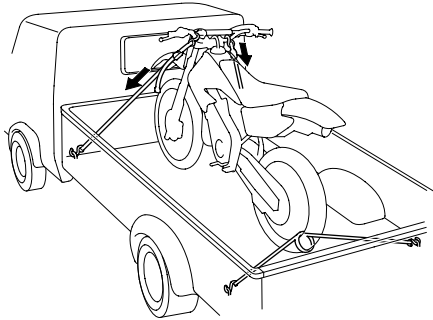

To secure your CRF, brace the front wheel against the front of the truck bed or trailer rail. Attach the lower ends of two straps to the tie-down hooks on your CRF. Attach the upper ends of the straps to the handlebar (one on the right side, the other on the left), close to the fork.

Check that the tie-down straps do not contact any control cables or electrical wiring.

Tighten both straps until the front suspension is compressed about half-way. Too much pressure is unnecessary and could damage the fork seals.

Use another tie-down strap to keep the rear of the motorcycle from moving.

We recommend that you do not transport your CRF on its side. This can damage the motorcycle, and leaking gasoline could be a hazard.

If you won't be riding for an extended period, such as during the winter, thoroughly inspect your CRF and correct any problem before storing it. That way, needed repairs won't be forgotten and it will be easier to get your CRF running again.

To reduce or prevent deterioration that can occur during storage, also follow the following procedures.

Preparation for Storage

1. Completely clean all parts of your CRF. If your CRF has been exposed to sea air or salt water, wash it down with fresh water and wipe dry.
2. Change the engine oil and filter (page 46).
3. Change the transmission oil (page 49).
4. Remove the radiator cap and coolant drain bolt and sealing washer (1) at the water pump cover (2) to drain coolant.
After the coolant has been completely drained, reinstall the drain bolt with a new sealing washer and radiator cap.
Tighten the drain bolt to the specified torque:
7 lbf·ft (10 N·m, 1.0 kgf·m)

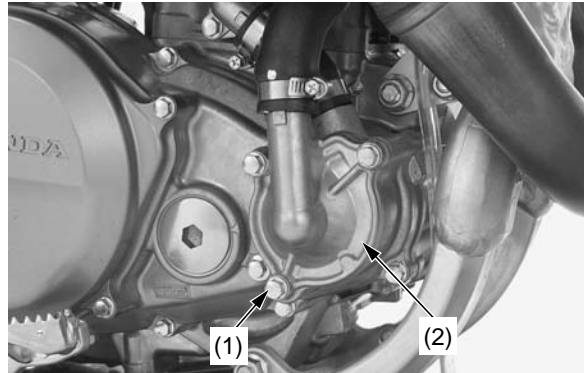

- (1) coolant drain bolt and washer
(2) water pump cover

5. Lubricate the drive chain.
6. Relieve the fuel pressure (page 41) and drain the fuel from the fuel tank into an approved gasoline container.
7. Inflate the tires to their recommended pressures.
8. Place your CRF on an optional workstand or equivalent to raise both tires off the ground.
9. Stuff a rag into the muffler outlet. Then tie a plastic bag over the end of the muffler to prevent moisture from entering.
10. Store your CRF in an unheated area, free of dampness, away from sunlight, with a minimum of daily temperature variation.
11. Cover your CRF with a porous material. Avoid using plastic or similar non-breathing, coated materials that restrict air flow and allow heat and moisture to accumulate.

Removal from Storage

1. Uncover and clean your CRF.
Change the engine and transmission oil if more than 4 months have passed since the start of storage.
2. Uncover the end of the muffler and remove the rag from the muffler outlet.
3. Fill the fuel tank with the recommended fuel (page 40) and increase the fuel pressure (page 44).
4. Pour a fresh recommended coolant mixture (page 50) slowly into the radiator filler hole up to the filler neck.
Capacity:
1.12 US qt (1.06 l)
after disassembly
1.10 US qt (1.04 l)
after draining

Lean your CRF slightly right and left several times to bleed trapped air in the cooling system.
If the coolant level lowers, add coolant and repeat the above procedure.
Install the radiator cap securely.
5. Perform all maintenance checks (page 13).

You & the Environment

Owning and riding a motorcycle can be enjoyable, but you must do your part to protect nature. When you show respect for the land, wildlife, and other people, you also help preserve the sport of off road riding.

Following are tips on how you can be an environmentally responsible motorcycle owner.

- **Choose Sensible Cleaners.** Use a biodegradable detergent when you wash your CRF. Avoid aerosol spray cleaners that contain chlorofluorocarbons (CFCs) which damage the atmosphere's protective ozone layer. Don't throw cleaning solvents away; see the following guidelines for proper disposal.
- **Recycle Wastes.** It's illegal and thoughtless to put used engine oil in the trash, down a drain, or on the ground. Used oil, gasoline, coolant, and cleaning solvents contain poisons that can hurt refuse workers and contaminate our drinking water, lakes, rivers, and oceans. Before changing your oil, make sure you have the proper containers. Put oil and other toxic wastes in separate sealed containers and take them to a recycling center. Call your local or state office of public works or environmental services to find a recycling center in your area and get instructions on how to dispose of non recyclable wastes.

NOTICE

Improper disposal of drained fluids is harmful to the environment.

The items that are serviceable using this Manual are followed by the page number reference in parenthesis. The items that require use of an official Honda Service Manual are followed by an asterisk (*).

ENGINE DOES NOT START OR IS HARD TO START

CHECK POSSIBLE CAUSES

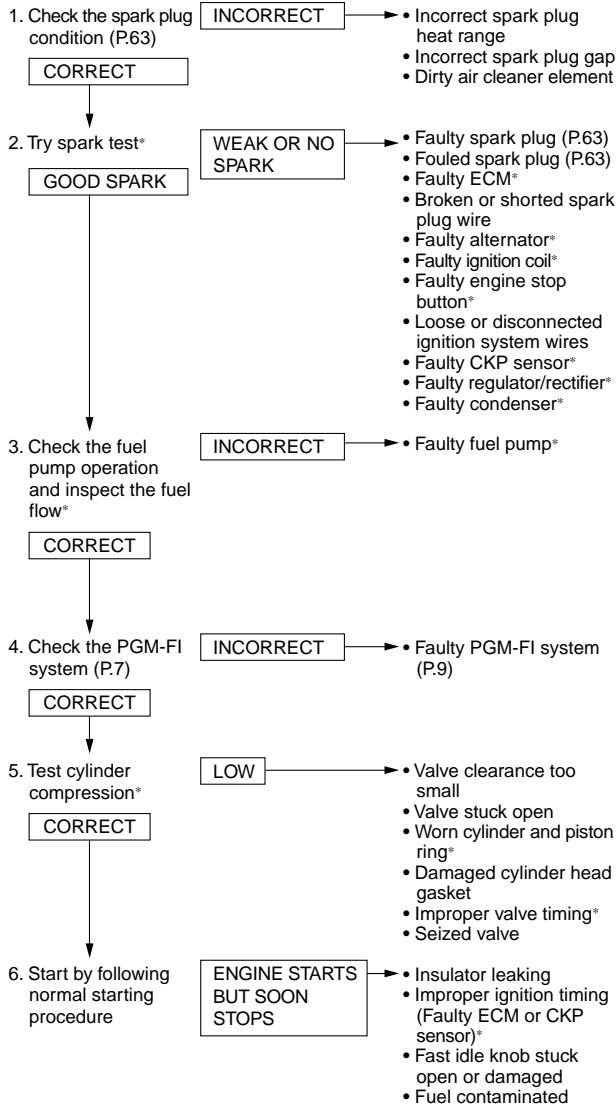

ENGINE LACKS POWER

CHECK

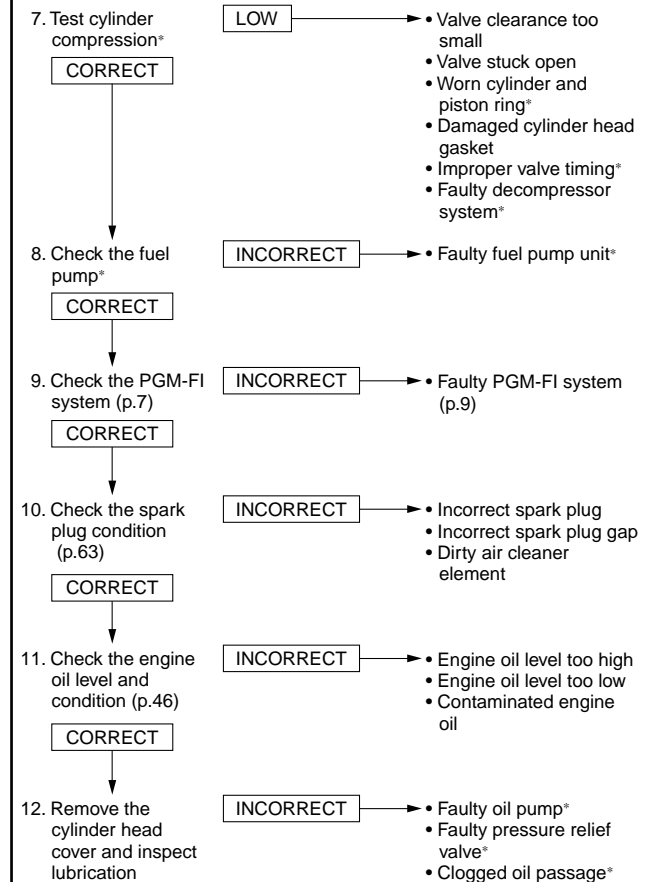
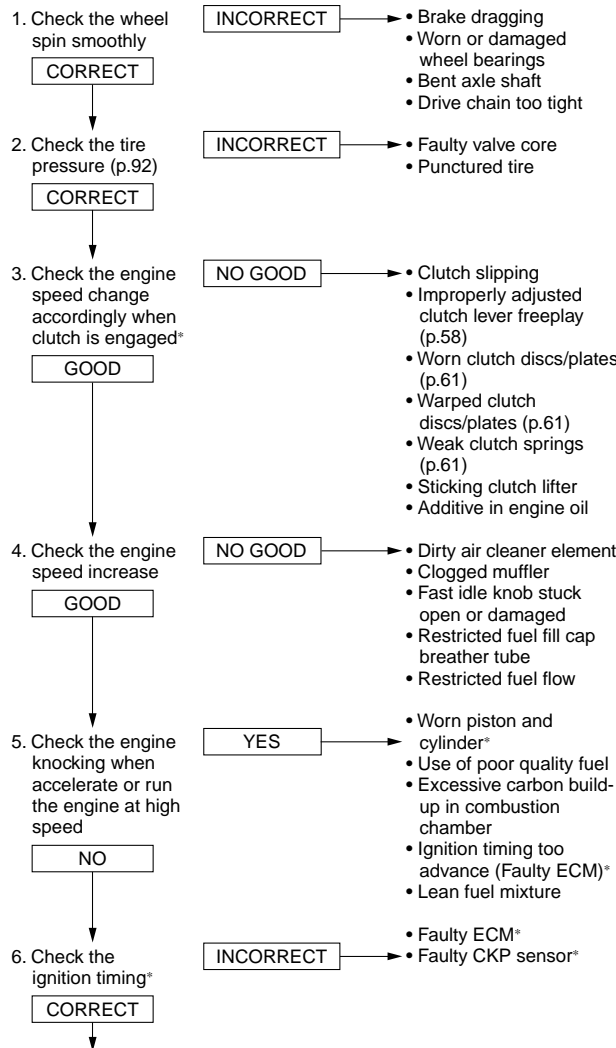

Troubleshooting

POOR PERFORMANCE AT LOW AND IDLE SPEED

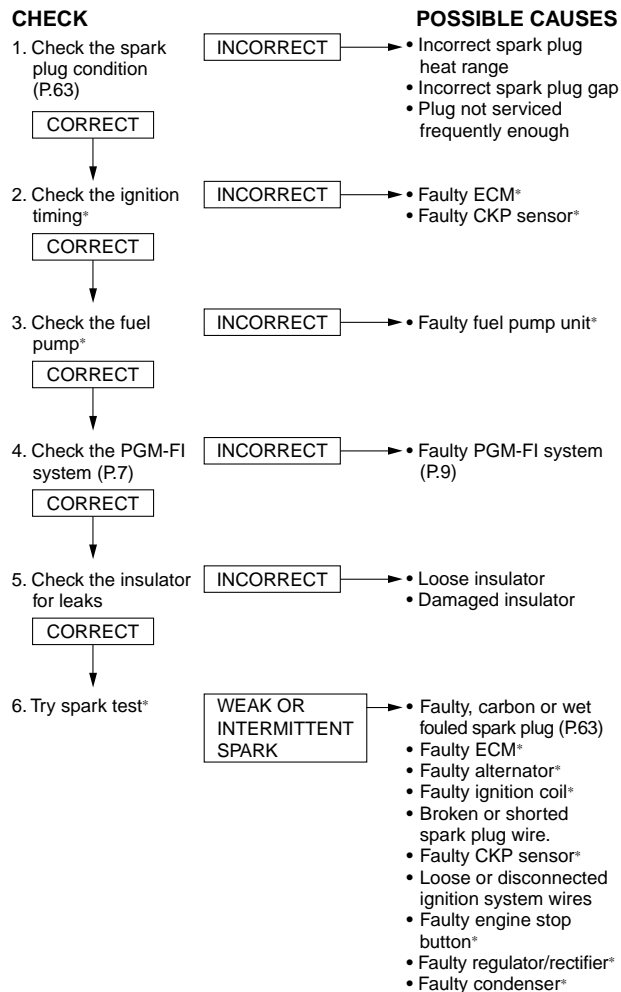

POOR PERFORMANCE AT HIGH SPEED

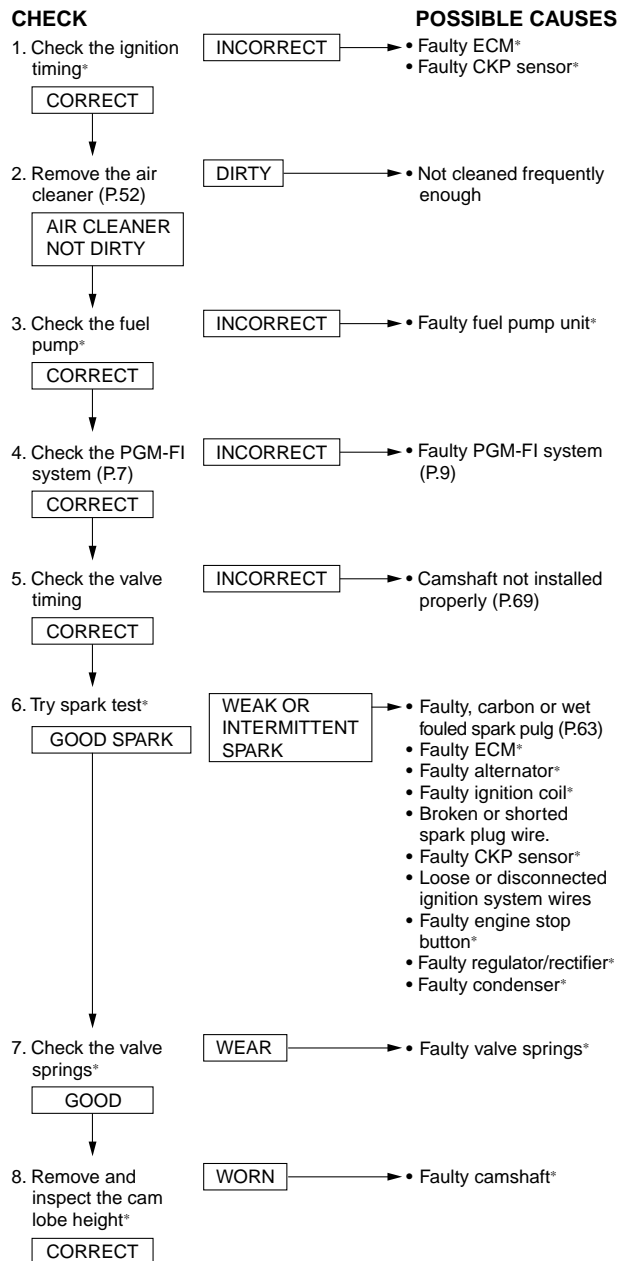

POOR HANDLING

Steering is heavy

- Steering stem adjusting nut too tight*
- Damaged steering head bearings
- Faulty HPSD*

Either wheel is wobbling

- Excessive wheel bearing play
- Bent rim
- Improperly installed wheel hub
- Excessively worn swingarm pivot bearings
- Bent frame

The motorcycle pulls to one side

- Front and rear wheels not aligned
- Bent fork
- Bent swingarm
- Bent axle shaft
- Bent frame

This section contains dimensions, capacities, and other technical data.

Vehicle Identification	144
Serial Numbers	144
Specifications	145
Torque Specifications	146
Nuts, Bolts, Fasteners	146
Oxygenated Fuels	149
Competition Logbook	150
Optional Parts List	152
Spare Parts & Equipment	153
Spare Parts	153
General Tools	153
Honda Special Tools	153
Chemical Products	153
Other Products	153
Wiring Diagram	154

Vehicle Identification

Serial Numbers

The VIN and engine serial number are required when you register your CRF. They may also be required when ordering replacement parts. You may record these numbers in the Quick Reference section at the rear of this manual.

The VIN (vehicle identification number) (1) is stamped on the right side of the steering head.



(1) VIN

The engine number (2) is stamped on the left crankcase.

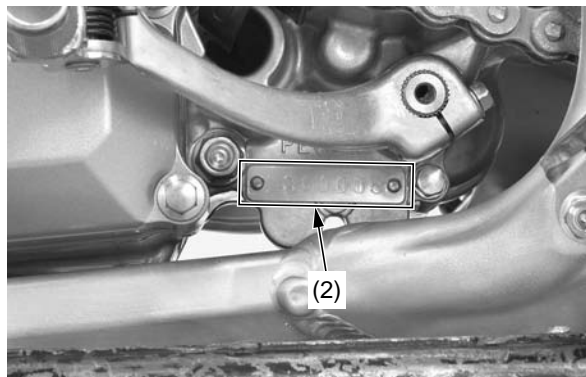

(2) engine number

Item	English	Metric
Dimension		
Overall length	86.3 in	2,191 mm
Overall width	32.6 in	827 mm
Overall height	50.1 in	1,273 mm
Wheelbase	58.7 in	1,491 mm
Seat height	37.6 in	954 mm
Footpeg height	16.7 in	424 mm
Ground clearance	13.1 in	332 mm
Frame		
Type	Twin tube	
F. suspension	Telescopic fork, travel 10.7 in (273 mm) stroke 12.2 in (310 mm)	
R. suspension	Pro-link, travel 12.6 in (320 mm)	
Tire size, front	80/100 – 21 51M	
	DUNLOP	D742FA
Tire size, rear	120/80 – 19 63M	
	DUNLOP	D756
Tire type	bias-ply, tube	
Tire pressure, front (cold)	15 psi (100 kPa, 1.0 kgf/cm ²)	
Tire pressure, rear (cold)	15 psi (100 kPa, 1.0 kgf/cm ²)	
F. brake, swept area	Single disc brake 51.8 in ² (334.5 cm ²)	
R. brake, swept area	Single disc brake 60.6 in ² (391.1 cm ²)	
Fuel	unleaded gasoline, pump octane number of 91 or higher	
Fuel tank capacity	1.5 US gal	5.7 ℓ
Caster angle	26°52'	
Trail length	4.5 in	114.2 mm
Fork oil capacity (except fork damper)	12.0 US oz	355 cm ³

Item	English	Metric
Engine		
Type	Liquid cooled, 4-stroke	
Cylinder arrangement	Single 6°30' inclined from vertical	
Bore and stroke	3.78 x 2.44 in	96.0 x 62.1 mm
Displacement	27.43 cu-in	449.7 cm ³
Compression ratio	12.0 : 1	
Valve clearance (cold)	Intake: 0.006 ± 0.001 in (0.16 ± 0.03 mm) Exhaust: 0.011 ± 0.001 in (0.28 ± 0.03 mm)	
Engine oil capacity after draining	0.61 US qt	0.58 ℓ
after draining and oil filter change	0.66 US qt	0.62 ℓ
after disassembly	0.81 US qt	0.77 ℓ
Transmission oil capacity after draining	0.62 US qt	0.59 ℓ
after disassembly	0.71 US qt	0.67 ℓ
Throttle body		
Identification number	GQD3A	
First idle speed	1,800 ± 100 rpm	
Cooling system		
Cooling capacity after draining	1.10 US qt	1.04 ℓ
after disassembly	1.12 US qt	1.06 ℓ

Item	English	Metric
Drive train		
Clutch type	Wet, multi-plate type	
Transmission	5-speed, constant mesh	
Primary reduction	2.739	
Gear ratio I	1.800	
Gear ratio II	1.470	
Gear ratio III	1.235	
Gear ratio IV	1.050	
Gear ratio V	0.909	
Final reduction	3.692	
Gear shift pattern	Left foot-operated return system 1-N-2-3-4-5	
Electrical		
Ignition	ECM	
Starting system	Kickstarter	
Spark plug : Standard	NGK SILMAR9A-9S	
For extended high speed riding	NGK SILMAR10A-9S	
Spark plug gap	0.031 – 0.035 in (0.8 – 0.9 mm)	

Torque Specifications

Nuts, Bolts, Fasteners

Check and tighten nuts, bolts, and fasteners before every outing.

LEFT SIDE

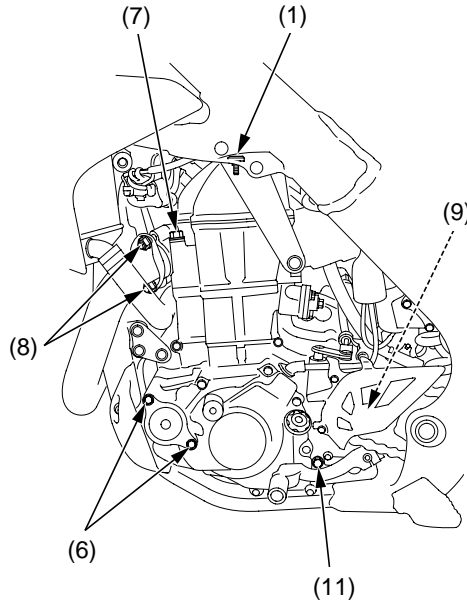

RIGHT SIDE

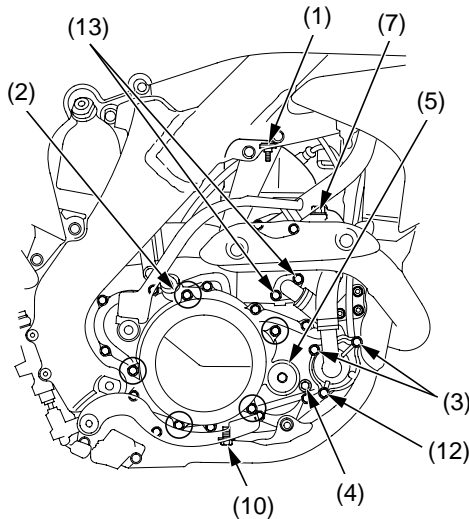

ENGINE

	Item	Torque			Remarks
		lbf•ft	N•m	kgf•m	
1	Cylinder head cover socket bolts	7	10	1.0	
2	Clutch cover bolts	7	10	1.0	
3	Water pump cover bolts	7	10	1.0	
4	Transmission oil check bolt	9	12	1.2	
5	Crankshaft hole cap	11	15	1.5	NOTE 1
6	Oil filter cover bolts	9	12	1.2	
7	Cylinder head bolts	38	51	5.2	NOTE 2
8	Exhaust pipe joint nuts	15	21	2.1	
9	Drive sprocket bolt	23	31	3.2	
10	Engine oil drain bolt	12	16	1.6	NOTE 2
11	Transmission oil drain bolt	12	16	1.6	NOTE 2
12	Coolant drain bolt	7	10	1.0	
13	Water hose joint bolts	7	10	1.0	

NOTE: 1. Apply grease to the threads.

2. Apply engine oil to the threads and seating surface

LEFT SIDE

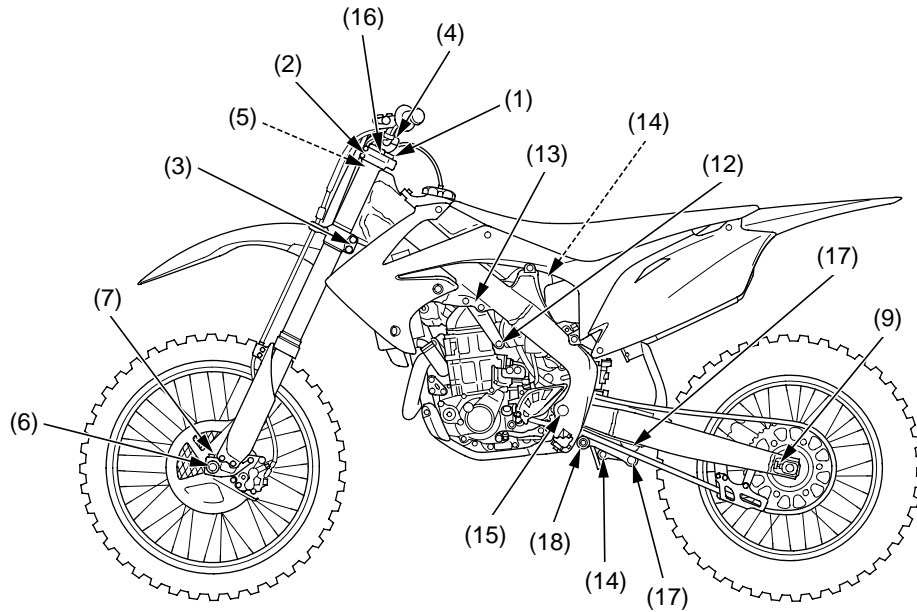

RIGHT SIDE

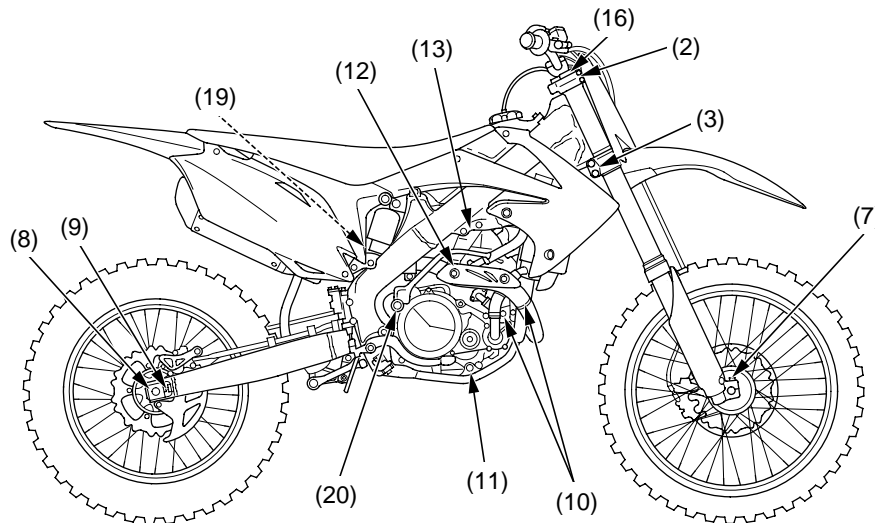

FRAME

Item	Torque			Remarks	
	lbf•ft	N•m	kgf•m		
1	Steering stem nut	80	108	11.0	
2	Fork bridge upper pinch bolts	16	22	2.2	
3	Fork bridge lower pinch bolts	15	20	2.0	
4	Handlebar upper holder bolts	16	22	2.2	
5	Handlebar lower holder nuts	32	44	4.5	
6	Front axle nut	65	88	9.0	
7	Axle pinch bolts	15	20	2.0	
8	Rear axle nut	94	128	13.1	NOTE 1
9	Chain adjuster lock nuts	20	27	2.8	NOTE 2
10	Front engine hanger nuts	40	54	5.5	
	Front engine hanger plate nuts	19	26	2.7	
11	Lower engine hanger nut	40	54	5.5	
12	Cylinder head hanger bolts	40	54	5.5	
13	Cylinder head hanger plate bolts	24	33	3.4	
14	Rear suspension (upper)	32	44	4.5	NOTE 1
	(lower)	32	44	4.5	NOTE 1
15	Swingarm pivot nut	65	88	9.0	NOTE 1
16	Fork (fork cap assembly)	21	28	2.9	
	(fork damper)	22	30	3.1	
17	Rear shock arm nuts				
	(swingarm side)	39	53	5.4	NOTE 1, 7
	(shock link side)	39	53	5.4	NOTE 1, 7
18	Rear shock link nuts				
	(Frame side)	39	53	5.4	NOTE 1, 7
19	Rear shock spring lock nut	21	28	2.9	
20	Kickstarter arm bolt	28	38	3.9	NOTE 6

- NOTES:
1. U-nut.
 2. UBS nut.
 3. Apply oil to the threads and flange surface.
 4. Apply locking agent to the threads.
 5. SH bolt
 6. A lock bolt: replace with a new one
 7. Apply molybdenum oil to the threads and flange surface

Torque Specifications

LEFT SIDE

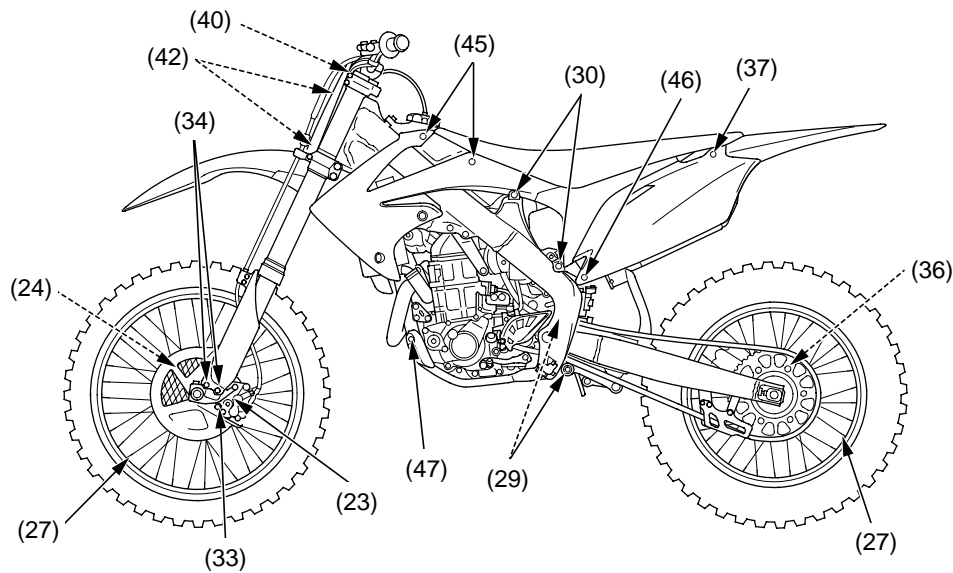

RIGHT SIDE

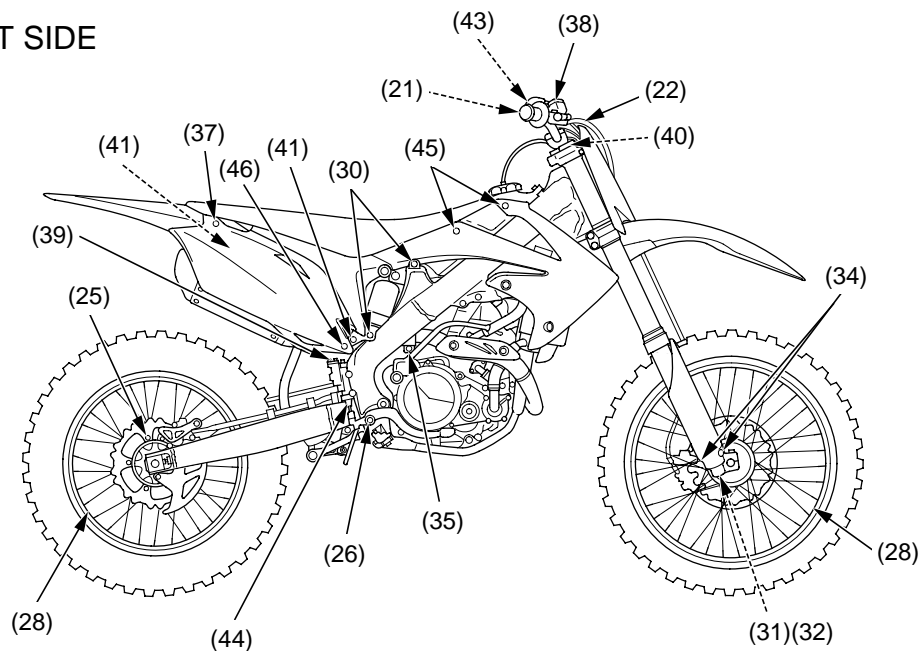

FRAME

Item	Torque			Remarks	
	lbf•ft	N•m	kgf•m		
21	Front brake master cylinder holder bolts	7.3	9.9	1.0	
22	Brake hose oil bolts	25	34	3.5	
23	Front brake caliper mounting bolts	22	30	3.1	NOTE 6
24	Front brake disc nuts	12	16	1.6	NOTE 1
25	Rear brake disc nuts	12	16	1.6	NOTE 1
26	Brake pedal pivot bolt	27	36	3.7	NOTE 6
27	Spokes (front)	2.7	3.7	0.4	
	(rear)	2.7	3.7	0.4	
28	Rim locks	9	12	1.2	
29	Drive chain roller (upper)	9	12	1.2	NOTE 5
	(lower)	9	12	1.2	NOTE 1
30	Subframe (upper) bolts	24	33	3.4	
	(Lower-left)	24	33	3.4	
	(Lower-right)	36	49	5.0	
31	Fork center bolt	41	55	5.6	NOTE 4
32	Fork center bolt lock nut	21	29	3.0	
33	Disc cover bolt	10	13	1.3	
34	Fork protector socket bolts	5.2	7	0.7	NOTE 6
35	Muffler clamp bolt	15	21	2.1	
36	Driven sprocket nuts	24	32	3.3	NOTE 1
37	Seat mounting bolts	19	26	2.7	
38	Front brake reservoir cap screws	0.7	1.0	0.1	
39	Rear brake reservoir cap bolts	0.7	1.0	0.1	
40	Fork air pressure release screw	0.9	1.2	0.1	
41	Muffler mounting Front side A, B bolts	19	26	2.7	
	Rear side	19	26	2.7	
42	Steering damper mounting bolts	15	20	2.0	NOTE 6
43	Throttle cable adjuster lock nuts	3.0	4	0.4	
44	Rear master cylinder push rod lock nut	4.4	5.9	0.6	
45	Shroud B bolts (upper)	3.7	5	0.5	
46	Side cover bolts	7	10	1.0	
47	Left engine guard/washer	7	10	1.0	

- NOTES:
1. U-nut.
 2. UBS nut.
 3. Apply oil to the threads and flange surface.
 4. Apply a locking agent to the threads.
 5. SH bolt
 6. Alock bolt: replace with a new one

Some conventional gasolines are being blended with alcohol or an ether compound. These gasolines are collectively referred to as oxygenated fuels. To meet clean air standards, some areas of the United States and Canada use oxygenated fuels to help reduce emissions. If you use an oxygenated fuel, be sure it is unleaded and meets the minimum octane rating requirement.

Before using an oxygenated fuel, try to confirm the fuel's contents. Some states/provinces require this information to be posted on the pump.

The following are the EPA-approved percentages of oxygenates:

ETHANOL (ethyl or grain alcohol) 10% by Volume

You may use gasoline containing up to 10% ethanol by volume. Gasoline containing ethanol may be marketed under the name "Gasohol".

MTBE (Methyl Tertiary Butyl Ether) 15% by Volume

You may use gasoline containing up to 15% MTBE by volume.

METHANOL (methyl or wood alcohol) 5% by Volume

You may use gasoline containing methanol containing up to 5% methanol by volume as long as it also contains cosolvents and corrosion inhibitors to protect the fuel system. Gasoline containing more than 5% methanol by volume may cause starting and/or performance problems. It may also damage metal, rubber, and plastic parts of your fuel system.

If you notice any undesirable operating symptoms, try another service station or switch to another brand of gasoline.

Fuel system damage or performance problems resulting from the use of an oxygenated fuel containing more than the percentages of oxygenates mentioned above are not covered under warranty.

Oxygenated fuels can damage paint and plastic. Be careful not to spill fuel when filling the fuel tank. Wipe up any spills immediately.

NOTICE

Oxygenated fuels can damage paint and plastic.

Competition Logbook

Any serious competition effort relies heavily on the knowledge gained and compiled from previous racing events. The best way to organize the many bits of information is to record them in a logbook.

Your logbook can include such information as suspension adjustments, steering damper adjustments, gearing, and tire selection. This detailed information, along with your comments, can prove valuable when you compete at the same track or on similar terrain.

Your logbook can also tell you when maintenance was performed and when it will be necessary again. Your logbook also lets you record any repairs and lets you keep track of the running time on the engine and suspension components.

If you choose to sell your CRF, the accurate maintenance records in your logbook might be the deciding deal-maker for a potential buyer.

Consider using different color pens or pencils to record important information on specific subjects. For example, record results in black, steering damper setting in red, suspension/chassis settings in blue, and gearing selections in green. Color codes will help you identify the information you want with a glance.

Tuning & Adjustment Records

Keep track of the settings and adjustments that worked best at a particular location. These items include:

- basic track conditions, altitude, and temperature
- suspension settings
- steering damper settings
- chassis adjustments tested and selected
- gearing
- tire selection
- air pressure

Competition Records

- your placings
- thoughts to improve performance next time: both yours and your CRF's
- strategy notes

Maintenance Records

- regular interval maintenance
- repairs
- running time on engine
- running time on suspension components

Timekeeping

This Manual lists maintenance intervals for every-so-many races or every-so-many hours of running.

Because all races are not the same, the most effective way to schedule maintenance is by the hours you have run your CRF.

An official “guesstimate” is close enough for our timekeeping purposes. You may choose to record your time the same way aircraft operators do (but without the benefit of an electrical hourmeter). All running time is broken down into hours and tenths of an hour (each six minutes represents one tenth of an hour).

Racing Records

Information worth recording for this section of your logbook may include:

- Your placing in each moto and overall finishing position.
- Thoughts on what you could do to improve your performance next time.
- Notes on any patterns noted in choice of starting gate positions or in riding portions of the course as the day progressed that may prove helpful in future events.
- Any places on the course where you chose the wrong line and were passed too easily.
- Notes on strategy used by your competition or by riders in another event that are worth remembering.

Maintenance Records

Regular maintenance items you'll want to record in your logbook should include:



- Dates and results of cylinder, piston and ring examinations
- Patterns for frequency of need for decarbonization with a particular oil
- When you last performed shock linkage and swingarm pivot bearing maintenance
- Engine, transmission, and suspension oil changes
- Chain, sprocket, chain guide and slider replacements
- Coolant changes and related component replacements
- Spark plug, brake pad and control cable replacements





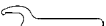

In addition, you should record any irregularities noted in component wear so you'll remember to keep a close eye on these areas in the future.

Optional Parts List

These parts and tools may be ordered from your authorized Honda dealer.

FRAME	Remarks
Driven sprocket Standard	< >: Drive chain links 48 Teeth, Aluminum. <116>
Optional	47 Teeth, Aluminum
	49 Teeth, Aluminum
Drive chain size/link	D.I.D 520DMA4/120RB RK520TXZ/120RJ
Handlebar lower holder	3 mm offset
Optional	no offset

TOOLS	Remarks
Pin spanner A 	To adjust spring preload. (two spanners required)
Workstand 	For maintenance
Air gauge	For checking tire air pressure

FRAME	Remarks
Shock spring Standard	308.3 lbf/in (54 N/mm) Pink paint (aftermarket parts) 
Optional Softer	296.9 lbf/in (52 N/mm) Yellow paint 
Stiffer	319.8 lbf/in (56 N/mm) White paint 
Fork spring Standard	26.27 lbf/in (4.6 N/mm) No mark (factory products) or 4 scribe marks (aftermarket parts)  
Optional Softer	25.12 lbf/in (4.4 N/mm) 2 scribe marks 
Stiffer	27.41 lbf/in (4.8 N/mm) 6 scribe marks 

The standard fork spring mounted on the motorcycle when it leaves the factory are not marked. Before replacing the springs, be sure to mark them so they can be distinguished from other optional springs.

There are numerous spare parts you can take to an event to help ensure you get in a full day of riding. In addition to the usual nuts and bolts, consider the following:

Spare Parts

spark plugs
air cleaner (clean & oiled, sealed in a plastic bag)
chain & masterlinks
chain guide slider
chain guide
chain rollers
tire tubes (front & rear)
fenders
footpegs
fuel feed hose and retainers
fuel pump
number plate & side covers
handlebar
grips
levers (brake & clutch)
clutch lever handlebar mount
clutch cable
throttle assembly
throttle cable
shift lever
brake pedal
spokes (front & rear, each side)
sprockets (larger & smaller than standard)
assorted nuts, bolts, washers, screws, cotter pins

Additional Spares

front brake master cylinder
rear brake assembly
wheels & tires (front & rear, mounted)
clutch discs and plates
engine & transmission oil
seat
ignition components
radiator hoses

radiator shrouds (L & R)
brake hoses (front & rear)

General Tools

sockets (3/8 in drive)
screwdrivers: blade & Phillips No. 1, 2, 3
wrench, large adjustable
wrenches: open end & box
wrenches: hex (Allen)
wrench, spoke
torque wrench (metric scale, click-stop style)
pliers: standard, needle-nose, channel-lock set
hammer, plastic head
syringe with adjustable stop
tire pressure gauge
tire irons
tire pump or air tank
feeler gauge set
Vernier caliper (metric)
pressure/vacuum testing equipment
Open end wrench 9/16 in (15 mm)

Honda Special Tools

Any special tools for your CRF purchased from your Honda dealer.

- Tensioner stopper 070MG-0010100
- Lock Nut Wrench 070MA-MEN0100
- Spoke Wrench 07JMA-MR60100
- Spoke Wrench 070MA-KZ30100
- Piston base 07958-2500001

You can purchase a PGM-FI Setting Tool for your CRF from your Honda dealer.

- PGM-FI Setting Tool 06380-N1C-770

Chemical Products

Pro Honda GN4 4-stroke Oil
(Engine and Transmission Oil)
KHL15-11 (KYB)
Pro Honda DOT 4 Brake Fluid
Pro Honda HP Chain Lube
Pro Honda Foam Filter Oil
Pro Honda Hondabrite
Pro Honda Dielectric Grease
Pro Honda Handgrip Cement
Pro Honda Hondalock
Molybdenum disulfide grease (containing more than 3% molybdenum disulfide additive)
Pro Honda White Lithium Grease
Multi-Purpose Grease
Rust-inhibiting oil
Cable lubricant
Pro Honda HP Coolant
Urea based multi-purpose grease designed for high temperature, high pressure performance (example: EXCELITE EP2 manufactured by KYODO YUSHI, Japan or Shell Stamina EP2 or equivalent)

Other Products

pliers-safety wire
safety wire
mechanic's wire
duct tape
plastic tie-wraps
hose clamps
drop light
electrical tape
Scotch-Brite Hand Pad #7447 (maroon)
Teflon tape

Wiring Diagram

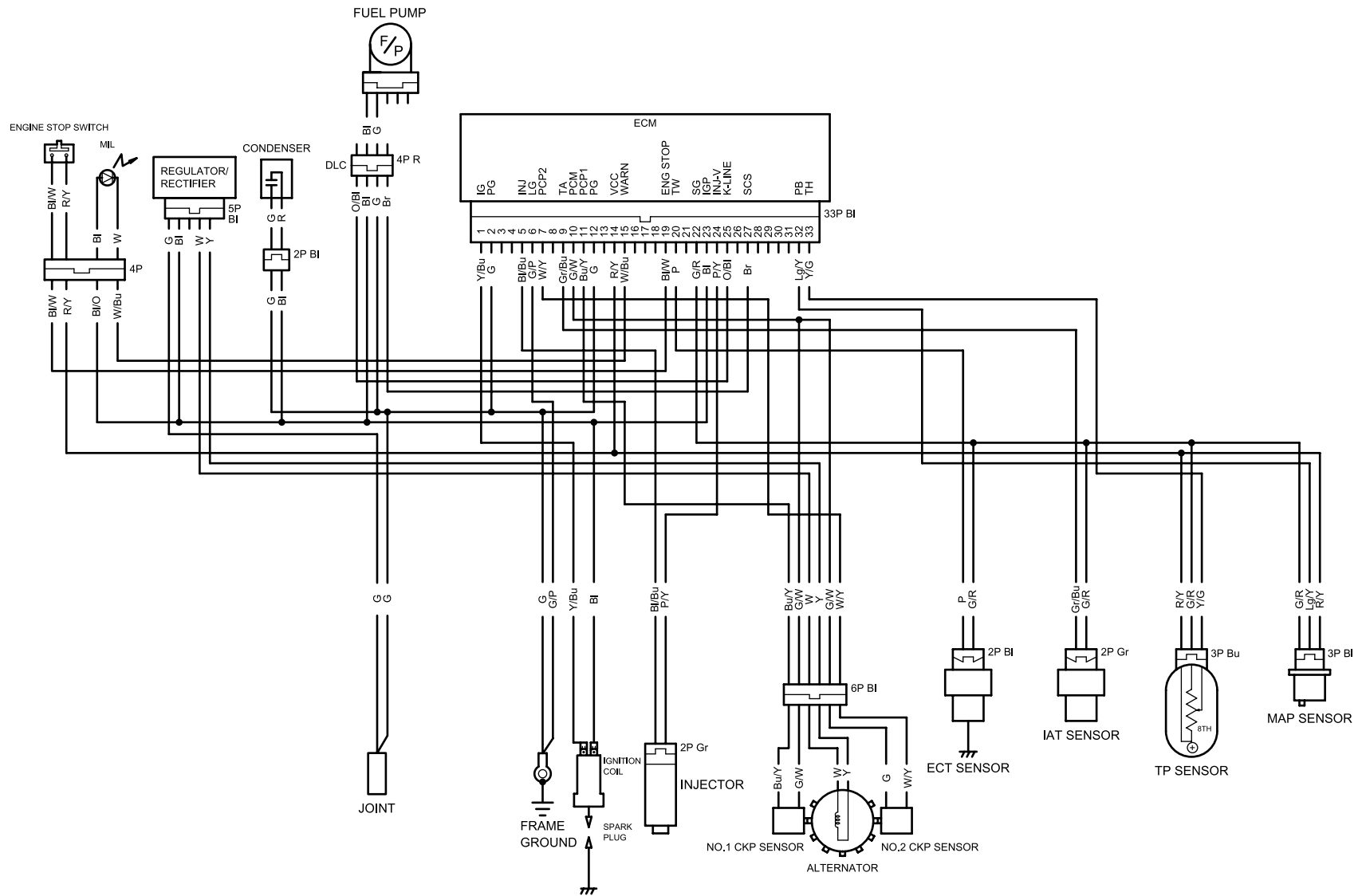

ENGINE STOP SWITCH		
	E	IG
FREE		
PUSH		
COLOR	BI/W	R/Y

BI	Black	Br	Brown
Y	Yellow	O	Orange
Bu	Blue	Lb	Light blue
G	Green	Lg	Light green
R	Red	P	Pink
W	White	Gr	Gray

This section contains information about contacting Honda and how to get an official Honda Service Manual.

Authorized Manuals	156
Contacting Honda.....	157
Your Honda Dealer.....	158
The Honda Rider's Club (USA only)	159

Authorized Manuals

The Service Manual used by your authorized Honda dealer is available from Helm, Inc (USA only, Canada: See your Honda dealer to order authorized manuals.)

Also available but not necessary to service your model is the Honda Common Service Manual which explains theory of operation and basic service information for various systems common to all Honda motorcycles, motor scooters and ATVs.

These Honda manuals are written for the professional technician, but most mechanically-capable owners should find them helpful if they have the proper tools and skills. Special Honda tools are necessary for some procedures.

Publication Item No.	Description	Price Each*
61MEN71	2010 CRF450R Service Manual	\$48.00
61CM002	Common Service Manual	\$48.00
31MEN660	2010 CRF450R Owner's Manual	\$16.00

*Prices are subject to change without notice and without incurring obligation.

Order On-Line: www.helminc.com

Order Toll Free: 1-888-CYCLE93 (1-888-292-5393)

(NOTE: For Credit Card Orders Only)
Monday - Friday 8:00 AM - 6:00 PM EST
OR

By completing this form you can order the materials desired. You can pay by check or money order, or charge to your credit card. Mail to Helm, Incorporated, at the address shown on this order form (USA only). Canada: See your Honda dealer to order authorized manuals.

Publication Item No.	Item Description	Qty.	Price Each*	Total Price
*Prices are subject to change without notice and without incurring obligation. Orders are mailed within 10 days. Please allow adequate time for delivery.		Sub Total		
		Purchaser's Sales Tax		
		Mich. add 6% Calif. add 8.25%		
		Handling Charge	\$3.75	
		Grand Total		

SHIP TO

NOTE: Dealers and Companies, please provide dealer or company name, and also the name of the person to whose attention the shipment should be sent. For purchases outside U.S.A., please write to the address shown below for a quotation.

Customer Name _____

Attention _____

Street address / P.O. BOX _____ Apt. # _____

City _____ State _____ Zip Code _____

Daytime Telephone Number () _____

PAYMENT

Check or money order enclosed payable to Helm, Inc. U.S. funds only. Do not send cash.

Master Card
 VISA
 Discover
 Check here if your billing address is different from the shipping address shown above.

Account Number

Expiration Date: Mo. Yr Security Code

-

Customer Signature _____ Date _____

These Publications cannot be returned for credit without receiving advance authorization within 14 days of delivery. For returns, a restocking fee may be applied against the original order.

HELM P.O. BOX 07280, DETROIT, MICHIGAN 48207

Your owner's manual was written to cover most of the questions you might ask about your CRF. Any questions not answered in the owner's manual can be answered by your Honda dealer. If your dealer doesn't have the answer right away, they will get it for you.

If you have a difference of opinion with your dealer, please remember that each dealership is independently owned and operated. That's why it's important to work to resolve any differences at the dealership level.

If you wish to comment on your experiences with your CRF or with your dealer, please send your comments to the following address (USA only):

Motorcycle Division, American Honda Motor Co., Inc., P.O. Box 2200, Torrance CA 90509-2200, Mailstop: 100-4C-7B,
Telephone: (866) 784-1870.

Canada: Refer to the warranty booklet that was supplied with your vehicle.

Please include the following information in your letter:

- name, address, and telephone number
- product model, year, and VIN
- date of purchase
- dealer name and address

We will likely ask your Honda dealer to respond, or possibly acknowledge your comments directly.

Your Honda Dealer

Once you purchase your new Honda, get familiar with the organization of your Honda dealer so you can utilize the full range of services available.

The service department is there to perform regular maintenance and unexpected repairs. It has the latest available service information from Honda.

The parts department offers Honda Genuine Parts, Pro Honda products, Honda Genuine Accessories (USA only), and Honda accessories and products (Canada only). The same quality that went into your Honda can be found in Honda Genuine replacement parts. You'll also find comparable quality in the accessories and products available from the parts department.

Your Honda dealer can inform you about competition events in your area. You'll also find that your dealer is a source of information the Honda Rider's Club of America (USA only).

We're sure you'll be as pleased with the service your Honda dealer continues to provide after the sale as you are with the quality and dependability of your Honda.

You may be eligible for a Honda Rider's Club of America (HRCA) membership with the purchase of your new Honda. You can log on to the HRCA Clubhouse website for details at www.hrca.honda.com.

Index

A

accessories	3
adjustments,	
chassis	133
control freerplay	55, 58, 87
for competition	107
gearing	134
personal fit	136
steering damper	131
suspension, front	108
suspension, rear	122
suspension, track conditions	126
tire selection	92
after competition maintenance	30
air cleaner	52
air pressure,	
front suspension	108
tires	92
apparel, protective	2
appearance care	105
authorized manuals	156

B

basic operation	15
before riding	11
between motos & practice maintenance	30
brakes,	
fluid level	88
lever, front adjustment	87
pad wear	90
pedal height	87
break-in guidelines	19

C

capacity, fuel	40
care, appearance	105
chain drive	94
chassis adjustments	133
cleaner, air	52
cleaning, appearance care	105
clutch system, adjustment	58
competition logbook	150
consumer information	155
contacting Honda	157
controls	5
coolant	50
customer service	158
cylinder system	75

D

damping adjustments,	
front	109
rear	123
steering damper	131
dealer, your Honda	158
diagram, wiring	154
drive chain	94

E

engine,	
flooded	17
idle speed	57
lacks power	141
number	144
oil	45
pinging	40
starting	17
stop button	18
stopping	18
won't start	141
environment, protecting	140

F

filter,	
air	52
oil	47
flooded engine, starting	17
fork,	
front suspension adjustment	108
front suspension inspection	83
oil recommendation	85
front brake lever adjustment	87
front suspension maintenance	108
fuel	40
fuel,	
line	40
line replacement	41
oxygenated	149
refueling	40
system	40
tank capacity	40

G

gap, spark plug63
 gasohol149
 gasoline.....40
 gearing.....134
 guidelines,
 steering damper132
 suspension adjustment127

H

handlebar inspection.....103
 Honda,
 contacting157
 Rider’s Club159
 service manual.....156
 your dealer.....158

I

identification, vehicle144
 idle knob, fast.....17,57
 idle speed, engine57
 indicator,
 circuit inspection8
 DTC index.....9
 MIL blink7
 inspection, pre-ride.....13
 instruments5

L

labels, safety4
 logbook, competition.....150

M

maintenance,
 after competition30
 before & after competition.....30
 between motos & practice.....30
 component locations32
 general competition.....26
 importance.....22
 safety23
 schedule.....24
 manual, service.....156
 modifications3

O

oil,
 engine45
 fork85
 transmission48
 operating instructions15
 operation component locations6
 optional,
 parts list152
 sprockets.....134
 oxygenated fuels.....149

P

pads, brake.....90
 parts, optional152
 personal fit adjustments136
 pinging, engine40
 plug, spark63
 pre-load, rear suspension.....122
 pre-ride inspection.....13
 protective apparel2

R

rear suspension maintenance.....122
 Rider’s Club Honda (USA only).....159
 riding,
 apparel2
 basic operation15
 before.....11
 important safety information.....2
 safety precautions.....2

S

safety,
 a few words aboutSafety Messages
 important information2
 important precautions.....2
 labels4
 maintenance.....23
 riding precautions.....16
 schedule, maintenance.....24
 seat33
 serial numbers144
 service,
 customer158
 manuals156
 spare parts.....153
 spark knock40
 spark plug,
 maintenance.....63
 reading.....130
 specifications.....145
 spring pre-load, rear suspension122
 starting,
 engine17
 troubleshooting.....141
 steering damper,
 adjustment.....131
 guidelines132
 operation inspection.....100
 steering stem inspection103

(cont’d)

Index

stopping engine	18
storage	139
subframe	36
suspension,	
front	83
rear.....	84
suspension adjustment,	
for track conditions	126
front	108
guidelines	127
rear.....	122

T

throttle,	
freeplay.....	55
inspection	56
tires,	
air pressure	92
flat	92
selection.....	93
tools	153
torque specifications	
engine	146
frame	147-148
transmission oil	48
transporting.....	138
troubleshooting.....	141
tubes, replacing	92
tuning tips.....	130

V

valve clearance	64
vehicle identification no. (VIN).....	144

W

washing your motorcycle.....	105
wheels.....	91
wiring diagram	154

Quick Reference

The following is a brief, but important collection of information you need to know about your CRF. You'll also find space to record important notes.

How To Avoid Costly Repairs

The engine of your CRF can be the most expensive component to repair. Proper maintenance, especially the use of the recommended fluids and filters, prevents premature wear and damage.

Frequent causes of costly engine repairs are:

- Transmission oil & engine oil: insufficient quantity, improper oil.
- Air cleaner: dirty, leaking because of improper installation (poor seal)

Record important information here:

VIN	
Engine No.	
Owner's:	
Name	
Address	
City/State	
Phone	
Dealer's:	
Name	
Address	
City/State	
Phone	
Service Mgr.	

Maintenance	The maintenance schedule (page 25) lists service frequencies for: each race or about 2.5 hours, every 3 races or about 7.5 hours, every 6 races or about 15.0 hours, every 9 races or about 22.5 hours and every 12 races or about 30.0 hours					
Pre-ride Inspection	Check the items listed on the Pre-ride Inspection checklist each time before you ride (page 13):					
Fuel/Tank Capacity	unleaded gasoline, pump octane number of 91 or higher tank: 1.5 US gal (5.7 l)					
Engine oil	Pro Honda GN4 4-stroke oil or an equivalent motorcycle oil.					
Transmission oil	Pro Honda GN4 4-stroke oil or an equivalent motorcycle oil.					
Tires	Front	80/100 – 21 51M		Rear	120/80 – 19 63M	
		DUNLOP	D742FA		DUNLOP	D756
	Type	bias-ply, tube				
Tire Pressure (cold)	Front: 15 psi (100 kPa, 1.0kgf/cm ²) Rear: 15 psi (100 kPa, 1.0kgf/cm ²)					
Spark Plug	standard: SILMAR9A-9S (NGK) optional: SILMAR10A-9S (NGK)					
Coolant	ethylene glycol antifreeze (silicate-free) for aluminum engines in 50/50 solution with Pro Honda HP Coolant or an equivalent distilled water.					
Drive Chain Size/Link	D.I.D 520DMA4/116RB					
	RK 520TXZ/116RJ					