

This manual should be considered a permanent part of the ATV and should remain with the ATV when it is resold.

This Owner's Manual covers the TRX450ER (electric starter) and TRX450R (kickstarter) models. You may find descriptions of equipment and features that are not on your particular model. All illustrations are based on the TRX450ER model.

This publication includes the latest production information available before printing. Honda Motor Co., Ltd. reserves the right to make changes at any time without notice and without incurring any obligation.

No part of this publication may be reproduced without written permission.

The vehicle pictured on the front cover may not match your vehicle.

© Honda Motor Co., Ltd. 2007

2008

Honda TRX450ER (electric starter)

Honda TRX450R (kickstarter)

SPORTRAX 450R

OWNER'S MANUAL

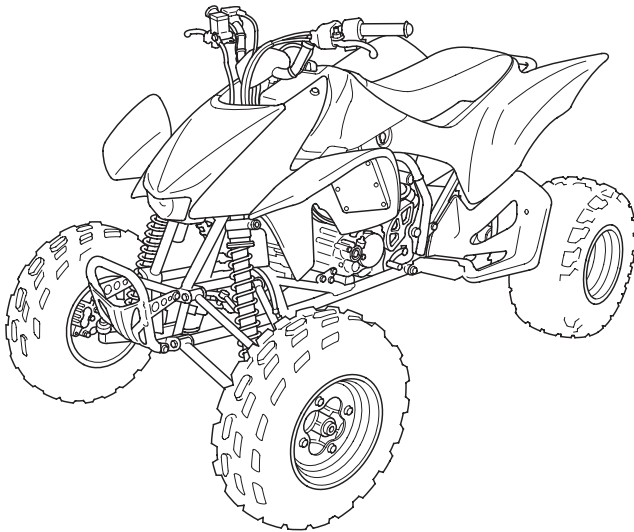

FOR OFF-ROAD USE ONLY

This vehicle is designed and manufactured for off-road use only.
USA only:

It conforms to US EPA Noise Emission regulations, but does not conform to Federal Motor Vehicle Safety Standards or US EPA On Highway Exhaust Emission regulations, and operation on public streets, roads, or highways is illegal. The vehicle is equipped with a USDA qualified spark arrester. Obey local laws and regulations.

It conforms to US EPA, California, and Environment Canada exhaust emission regulations for ATVs.

Introduction

Congratulations on choosing your Honda ATV.

When you own a Honda, you're part of a worldwide family of satisfied customers — people who appreciate Honda's reputation for building quality into every product.

Your Honda was designed as a recreational ATV for off-road use by one rider only.

Before riding, take time to get acquainted with your ATV and how it works. To protect your investment, we urge you to take responsibility for keeping your ATV well maintained. Scheduled service is a must, of course. But it's just as important to observe the break-in guidelines, and perform all pre-ride and other periodic checks detailed in this manual.

We also recommend that you read this owner's manual before you ride. It's full of facts, instructions, safety information, and helpful tips. To make it easy to use, the manual contains a detailed list of topics at the beginning of each section, and both an in-depth table of contents and an index at the back of the book.

As you read this manual, you will find information that is preceded by a **NOTICE** symbol. This information is intended to help you avoid damage to your Honda, other property, or the environment.

Read the Warranties Booklet (page 217) thoroughly so you understand the coverages that protect your new Honda and are aware of your rights and responsibilities.

Whenever you ride, tread lightly. By staying on established trails and riding only in approved areas, you help protect the environment and keep off-road riding areas open for the future.

Introduction

If you have any questions, or if you ever need special service or repairs, remember that your Honda dealer knows your ATV best and is dedicated to your complete satisfaction.

Please report any change of address or ownership to your Honda dealer so we will be able to contact you concerning important production information.

You may also want to visit our website at www.honda.com.

Happy riding!

California Proposition 65 Warning

WARNING: This product contains or emits chemicals known to the State of California to cause cancer and birth defects or other reproductive harm.

A Few Words About Safety

Your safety, and the safety of others, is very important. And operating this ATV safely is an important responsibility.

To help you make informed decisions about safety, we have provided operating procedures and other information on labels and in this manual. This information alerts you to potential hazards that could hurt you or others.

Of course, it is not practical or possible to warn you about all hazards associated with operating or maintaining an ATV. You must use your own good judgment.

You will find important safety information in a variety of forms, including:

Safety Labels — on the ATV.

Safety Messages — preceded by a safety alert symbol  and one of three signal words: **DANGER**, **WARNING**, or **CAUTION**.

A Few Words About Safety

These signal words mean:

 **DANGER**

You **WILL** be **KILLED** or **SERIOUSLY HURT** if you don't follow instructions.

 **WARNING**

You **CAN** be **KILLED** or **SERIOUSLY HURT** if you don't follow instructions.

 **CAUTION**

You **CAN** be **HURT** if you don't follow instructions.

Safety Headings — such as Important Safety Reminders or Important Safety Precautions.

Safety Section — such as ATV Safety.

Instructions — how to use this ATV correctly and safely.

This entire manual is filled with important safety information — please read it carefully.

Contents

These pages give an overview of the contents of your owner's manual. The first page of each section lists the topics covered in that section.

ATV Safety	1
Important safety information you should know, plus a look at the safety-related labels on your ATV.	
Indicators & Controls	9
The location and function of indicators and controls on your ATV and operating instructions for various controls and features.	
Before Riding.....	27
The importance of wearing a helmet and other protective gear, how to make sure you and your ATV are ready to ride, and important information about loading.	
Basic Operation & Riding	41
How to start and stop the engine, shift gears, and brake. Also, riding precautions.	

Contents

Servicing Your Honda	73
Why your ATV needs regular maintenance, what you need to know before servicing your Honda, an owner maintenance schedule, and instructions for specific maintenance and adjustment items.	
Tips	169
How to store and transport your ATV and how to be an environmentally-responsible rider.	
Taking Care of the Unexpected	179
What to do if you have a flat tire, your engine won't start, etc.	
Technical Information	197
ID numbers, technical specifications, and other technical facts.	
Consumer Information	213
Information on warranties, emission controls, how to get Honda service manuals.	
Table of Contents	222
Sequential listing of topics in this owner's manual.	
Index	228
Quick Reference	
Handy facts about fuel, engine oil, tire sizes, and air pressures.	

ATV Safety

This section presents some of the most important information and recommendations to help you ride your ATV safely. Please take a few moments to read these pages. This section also includes information about the location of safety labels on your ATV.

Important Safety Information	2
Safety Labels.....	5

Important Safety Information

Your ATV can provide many years of service and pleasure — if you take responsibility for your own safety and understand the challenges you can meet while riding.

There is much that you can do to protect yourself when you ride. You'll find many helpful recommendations throughout this manual. The following are a few that we consider most important.

Follow the Age Recommendation

The minimum recommended age for this ATV model is 16. Children under age 16 should never operate this vehicle.

Always Wear a Helmet

It's a proven fact: helmets significantly reduce the number and severity of head injuries. So always wear an approved motorcycle helmet. We also recommend that you wear eye protection, sturdy boots, gloves, and other protective gear (page 28).

Never Carry a Passenger

Your ATV is designed for one person only. There are no handholds, footrests, or seat for a second person — so never carry a passenger. A passenger could interfere with your ability to move around to maintain your balance and control of the ATV.

Important Safety Information

Ride Off-Road Only

Your ATV is designed and manufactured for off-road use only. The tires are not made for pavement, and the ATV does not have turn signals and other features required for use on public roads. If you need to cross a paved or public road, get off and walk your ATV across.

Take Time to Learn & Practice

Even if you have ridden other ATVs, take time to become familiar with how this ATV works and handles. Practice in a safe area until you build your skills and get accustomed to the ATV's size and weight.

Because many accidents involve inexperienced or untrained riders, we urge all riders to take a training course approved by the ATV Safety Institute (ASI). See page 30 .

Contact an authorized ATV dealer or call 1-800-887-2887 (USA only) to find out about the training courses nearest you.

Be Alert for Off-Road Hazards

The terrain can present a variety of challenges when you ride off-road. Continually “read” the terrain for unexpected turns, drop-offs, rocks, ruts, and other hazards. Always keep your speed low enough to allow time to see and react to hazards.

Important Safety Information

Ride within Your Limits

Pushing limits is another major cause of ATV accidents. Never ride beyond your personal abilities or faster than conditions warrant. Remember that alcohol, drugs, fatigue, and inattention can significantly reduce your ability to make good judgments and ride safely.

Don't Drink and Ride

Alcohol and riding don't mix. Even one drink can reduce your ability to respond to changing conditions, and your reaction time gets worse with every additional drink. So don't drink and ride, and don't let your friends drink and ride either.

Keep Your Honda in Safe Condition

It's important to keep your ATV properly maintained and in safe riding condition. Having a breakdown can be difficult, especially if you are stranded off-road far from your base. To help avoid problems, inspect your ATV before every ride and perform all recommended maintenance.

Safety Labels

Your ATV comes with a hang tag and several labels containing important safety information. Anyone who rides the vehicle should read and understand this information before riding.

The labels should be considered permanent parts of the vehicle. If a label comes off or becomes hard to read, contact your Honda dealer for replacements.

Safety Labels

USA only

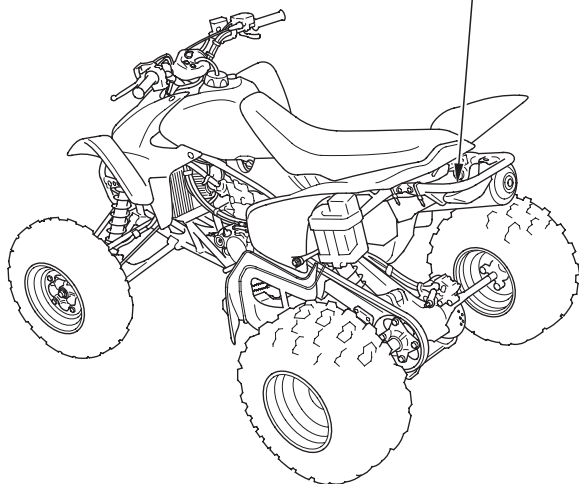
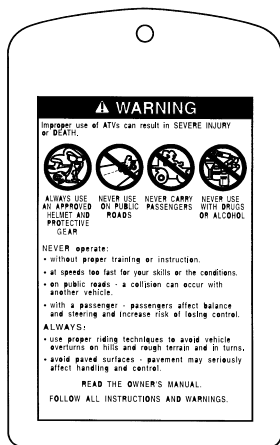

Safety Labels

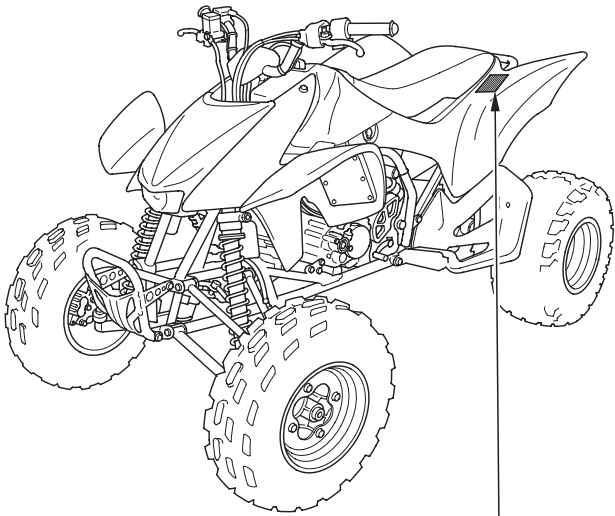

WARNING

Improper tire pressure or overloading can cause loss of control.

Loss of control can result in severe injury or death.

• Cold tire pressure :

Front : 27,5kPa 0,275kgf / cm² 4,0psi

Rear : 32,5kPa 0,325kgf / cm² 4,7psi

• Maximum weight capacity : 110kg (243lbs)

Safety Labels

WARNING

Improper use of ATVs can result in SEVERE INJURY or DEATH



ALWAYS USE HELMET AND PROTECTIVE GEAR. NEVER USE ON PUBLIC ROADS. NEVER CARRY PASSENGERS WITH DRUGS OR ALCOHOL. NEVER USE ATVs WITH DRUGS OR ALCOHOL.

NEVER operate:

- without proper training or instruction.
- at speeds too fast for your skills or the conditions.
- on public roads - a collision can occur with another vehicle.
- with a passenger - passengers affect balance and steering and increase risk of losing control.

ALWAYS:

- use proper riding techniques to avoid vehicle overturns on hills and rough terrain and in turns.
- avoid paved surfaces - pavement may seriously affect handling and control.

READ THE OWNER'S MANUAL.

FOLLOW ALL INSTRUCTIONS AND WARNINGS.

DANGER WARNING
危険

▶ NEVER OPEN WHEN HOT.
Hot coolant will scald you.
▶ N'OUVREZ PAS QUAND CHAUD.
N'EST PAS HEISSER MOTOR OFFEN.
▶ 熱湯がこぼれかきやがた。
冷却液 湯物打す

1.1

WARNING

UNDER 16

Operating this ATV if you are under the age of 16 increases your chance of severe injury or death.

NEVER operate this ATV if you are under age 16.

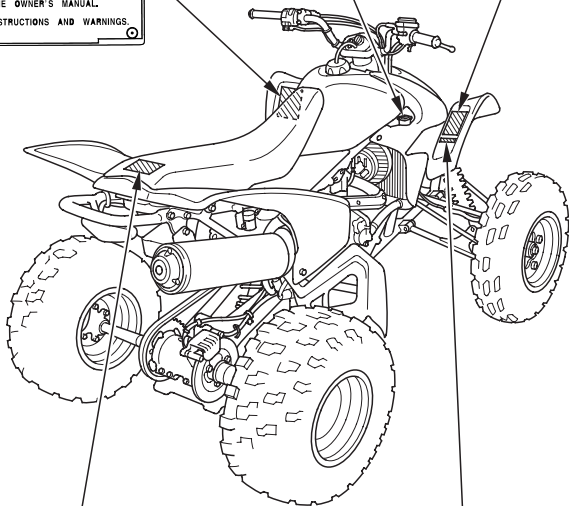

WARNING



NEVER ride as a passenger. Passengers can cause a loss of control, resulting in SEVERE INJURY or DEATH.

(For Canada)

THIS VEHICLE IS AN ALL-TERRAIN VEHICLE AND IS NOT INTENDED FOR USE ON PUBLIC HIGHWAYS.
CE VÉHICULE EST UN VÉHICULE TOUT TERRAIN ET DONT L'USAGE N'EST PAS DESTINÉ AUX VOIES PUBLIQUES.

Indicators & Controls

This section shows the location of all indicators and controls you would normally use before or while riding your ATV.

The items listed on this page are described in this section. Instructions for other components are presented in other sections of this manual where they will be most useful.

Operation Component Locations	10
Indicators.....	13
High Coolant Temperature Indicator	13
Neutral Indicator (TRX450ER only).....	14
Controls & Features	15
Fuel Valve	15
Choke Knob	16
Hot Start Lever (TRX450R only).....	17
Ignition Switch	18
Start Button (TRX450ER only).....	19
Kickstarter (TRX450R only).....	20
Engine Stop Switch.....	21
Headlight Switch.....	22
Headlight Dimmer Switch.....	22
Throttle Lever	23
Clutch Lever/Parking Brake Lever	23
Front Brake Lever	24
Rear Brake Pedal.....	24
Parking Brake.....	25
Flag Pole Bracket	26

Operation Component Locations

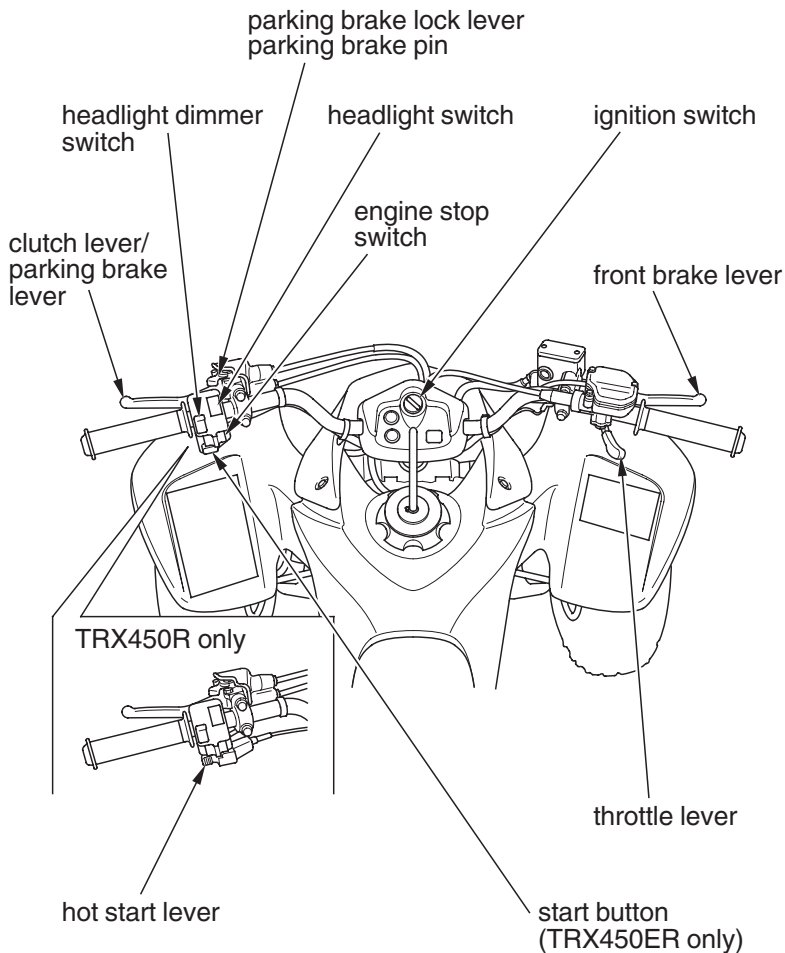

Operation Component Locations

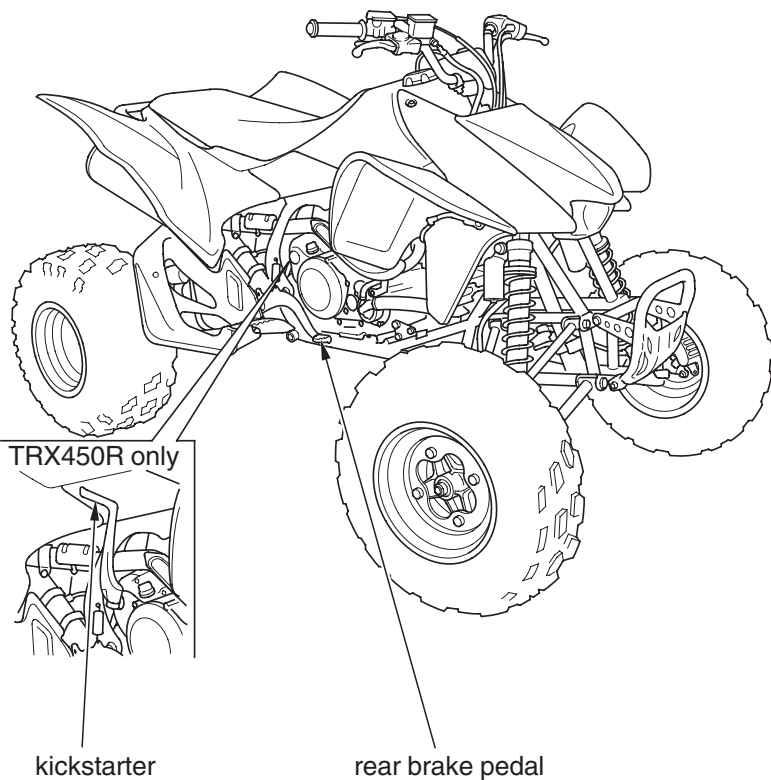

Operation Component Locations

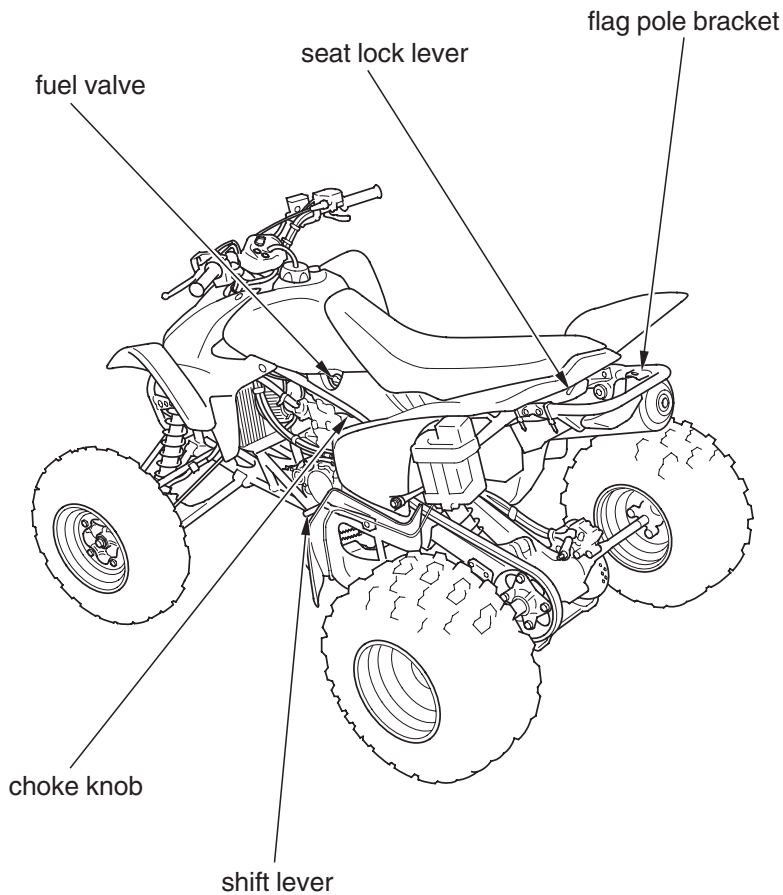

Indicators

High Coolant Temperature Indicator

CENTER OF HANDLEBAR

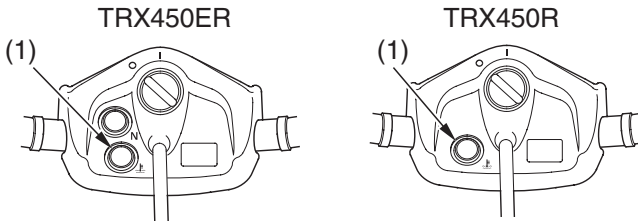

(1) high coolant temperature indicator

Lights when the engine coolant temperature is high enough to adversely affect the service life of the engine.

If the high coolant temperature indicator (1) comes on while you are riding, immediately bring the vehicle to a stop, turn the engine off and let it cool. See page 189.

Lamp Check (TRX450ER)

The high coolant temperature indicator comes on for a few seconds and then goes off when you turn the ignition switch to ON (I).

(TRX450R)

The engine is started when you operate the kickstarter, you can see the indicator comes on at the same time. If the engine is running, the indicator will go off after a few seconds. If the engine is stopping, the indicator will go off at the same time.

If the indicator does not come on when it should, have your Honda dealer check for a burned-out bulb or other problems.

Indicators

Neutral Indicator (TRX450ER only)

CENTER OF HANDLEBAR

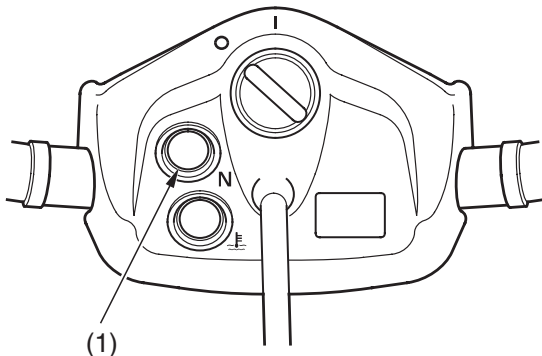

(1) neutral indicator

The neutral indicator (1) will light when the transmission is in neutral and the ignition switch is ON (I).

If the indicator does not come on when it should, have your Honda dealer check for a burned-out bulb or other problems.

Controls & Features

Fuel Valve

LEFT SIDE

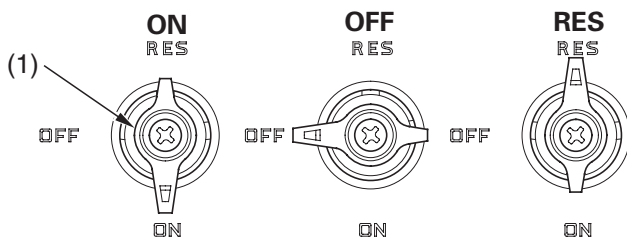

(1) fuel valve

The manual fuel valve (1) is located on the left side under the fuel tank.

The three-way fuel valve is used to control the flow of fuel from the fuel tank to the carburetor.

ON – normal position for riding.

OFF – for parking, storing, or transportation.

RES – for extra fuel to get to a gas supply for refueling.

Reserve Fuel

Remember to check that the fuel valve is in the ON position each time you refuel. If the fuel valve is left in the RES position, you may run out of fuel with no reserve.

For complete information about fueling your ATV, see page 89 .

Controls & Features

Choke Knob



LEFT SIDE

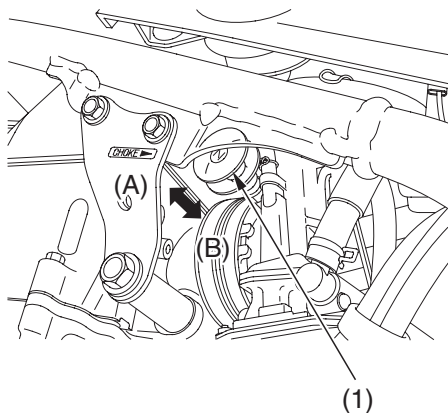

(1) choke knob

(A) fully ON

(B) fully OFF

The choke knob (1) may be used when starting the engine. See page 50 .

Controls & Features

Hot Start Lever (TRX450R only)

LEFT HANDLEBAR

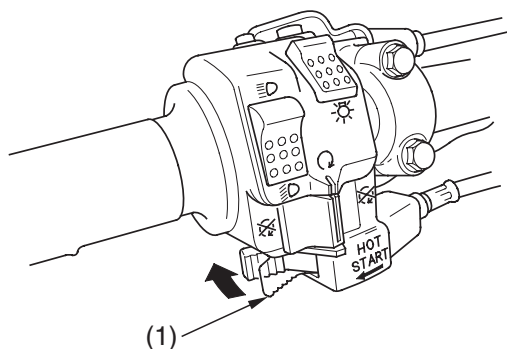

(1) hot start lever

The hot start lever (1) may be used when starting a warm engine. See page 53 .

Controls & Features

Ignition Switch

The ignition switch (1) is used for starting and stopping the engine (page 47). Insert the key and turn it to the right for the ON (|) position.

Key Position	Function
ON ()	Electrical circuits on.
OFF (○)	No electrical circuits function.

CENTER OF HANDLEBAR

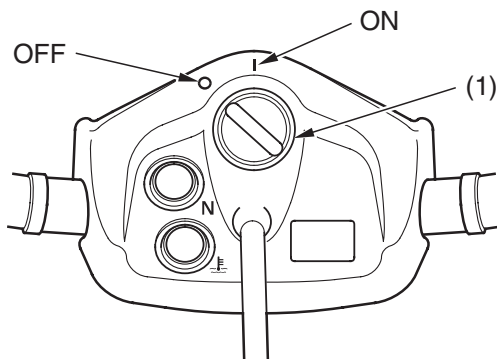

(1) ignition switch

| ON
○ OFF

Controls & Features

Start Button (TRX450ER only)



LEFT HANDLEBAR

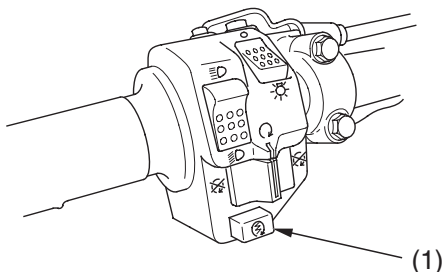

(1) start button

 START

The start button (1) is used for starting the engine. Pushing the button starts the engine. See *Starting Procedure*, page 50.

When the start button is pushed, the starter motor will crank the engine. The starter motor will operate even if the engine stop switch is in the OFF () position when the start button is pushed.

Controls & Features

Kickstarter (TRX450R only)

RIGHT SIDE

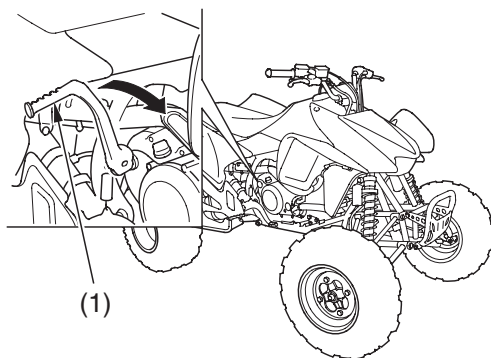

(1) kickstarter

The kickstarter (1) is used to start the engine. To operate, swing the kickstarter out from its stored position and depress it through its entire stroke. See Starting Procedure, page 51 .

Controls & Features

Engine Stop Switch



LEFT HANDLEBAR

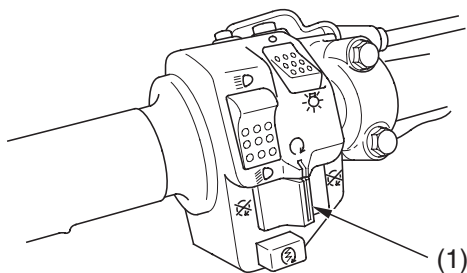

(1) engine stop switch

○ RUN
⊗ OFF

The engine stop switch (1) is used to stop the engine in an emergency. To operate, slide the switch to the OFF (⊗) position. The switch must be in the RUN (○) position to start the engine, and it should normally remain in the RUN (○) position even when the engine is OFF.

(TRX450ER only)

If your ATV is stopped with the ignition switch ON (I) and the engine stop switch OFF (⊗), the battery will discharge. Turn the ignition switch OFF (○) to prevent battery discharge.

Controls & Features

Headlight Switch



LEFT HANDLEBAR

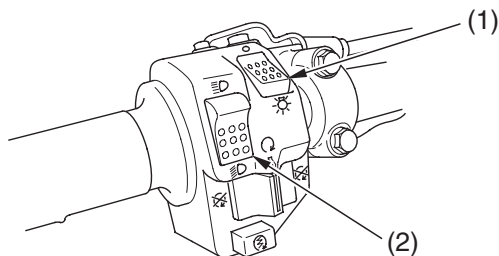

(1) headlight switch

(2) headlight dimmer switch

- OFF
- ☀ ON
- ≡D HI
- ≡D LO

The headlight switch (1) is used to turn the headlight ON (☀) or OFF (●). To operate, turn the switch to ON (☀) or OFF (●).

Headlight Dimmer Switch



The headlight dimmer switch (2) is used to change between the high and low beams of the headlight. To operate, turn the switch to HI (≡D) for high beam, LO (≡D) for low beam.

Controls & Features

Throttle Lever

RIGHT HANDLEBAR

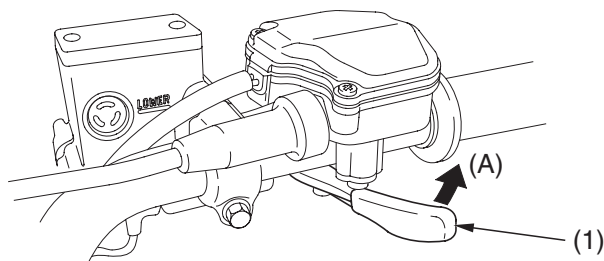

(1) throttle lever

(A) to open the throttle

The throttle controls engine rpm (speed). To increase engine rpm, press the throttle lever (1) with your thumb. To reduce engine rpm, release pressure on the throttle lever. The throttle will automatically return to the closed position (engine idle) when you remove your thumb.

Clutch Lever/Parking Brake Lever

The clutch lever/parking brake lever is used to disengage the clutch whenever you shift gears. To operate, pull the clutch lever/parking brake lever in all the way before shifting, then slowly release it after shifting. See *Clutch System*, page 116.

Controls & Features

Front Brake Lever

The front brake lever is used to slow or stop your ATV. To operate, pull the lever. For information on braking techniques, see page 58 .

Rear Brake Pedal

The rear brake pedal is used to slow or stop your ATV. To operate, depress the pedal. For information on braking techniques, see page 58 .

Controls & Features

Parking Brake

LEFT HANDLEBAR

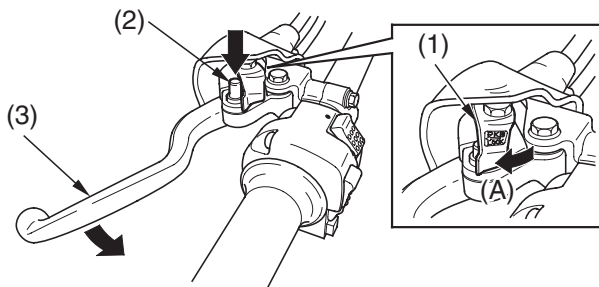

(1) lock lever

(2) parking brake pin

(3) clutch lever/parking brake lever

(A) to lock

The lock lever (1) and parking brake pin (2) on the clutch lever/parking brake lever (3) allows it to be used as a parking brake. To operate, push down and hold the parking brake pin, squeeze the clutch lever/parking brake lever and then lock it with the lock lever. See *Parking* page 72 .

To release the parking brake, squeeze the clutch lever/parking brake lever.

Controls & Features

Flag Pole Bracket

RIGHT REAR

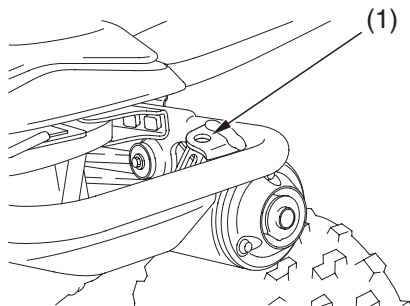

(1) flag pole bracket

Flag poles are optional equipment available from your Honda dealer. To mount a pole in the bracket (1), follow the instructions that come with the flag pole kit.

Flag poles are required in some riding areas. Check local regulations before riding.

Before Riding

Before each ride, you need to make sure you and your Honda are both ready to ride. To help get you prepared, this section discusses how to evaluate your riding readiness, what items you should check on your ATV, and adjustments to make for your comfort, convenience, or safety. This section also includes important information about loading.

Are You Ready to Ride?	28
Protective Apparel.....	28
Rider Training	30
Age Recommendation	31
No Passengers	31
No Alcohol or Drugs.....	32
Is Your ATV Ready to Ride?.....	33
Pre-ride Inspection	33
Load Limits & Guidelines.....	36
Loading	36
Load Limits	37
Loading Guidelines	38
Accessories & Modifications	39
Accessories.....	39
Modifications	40

Are You Ready to Ride?

Before you ride your ATV for the first time, we urge you to:

- Read this owner's manual and the labels on your ATV carefully.
- Make sure you understand all the safety messages.
- Know how to operate all the controls.

Before each ride, be sure:

- You feel well and are in good physical and mental condition.
- You are wearing an approved motorcycle helmet (with chin strap tightened securely), eye protection, and other protective clothing.
- You don't have any alcohol or drugs in your system.

Protective Apparel

For your safety, we strongly recommend that you always wear an approved motorcycle helmet, eye protection, boots, gloves, long pants, and a long-sleeved shirt or jacket whenever you ride.

Although complete protection is not possible, wearing proper gear can reduce the chance of injury when you ride.

Following are suggestions to help you choose the proper gear.

Helmets and Eye Protection

Your helmet is your most important piece of riding gear because it offers the best protection against head injuries. A helmet should fit your head comfortably and securely.

Are You Ready to Ride?

An open-face helmet offers some protection, but a full-face helmet offers more. Regardless of the style, look for a DOT (Department of Transportation) sticker on any helmet you buy (USA only). Always wear a face shield or goggles to protect your eyes and help your vision.

WARNING

Operating this ATV without wearing an approved motorcycle helmet, eye protection, and protective clothing could increase your chances of severe injury or death in the event of an accident.

Always wear an approved motorcycle helmet that fits properly and wear eye protection (goggles or face shield), gloves, boots, long-sleeved shirt or jacket and long pants.

Additional Riding Gear

In addition to a helmet and eye protection, we also recommend:

- Sturdy off-road motorcycle boots to help protect your feet, ankles, and lower legs.
- Off-road motorcycle gloves to help protect your hands.
- Riding pants with knee and hip pads, a riding jersey with padded elbows, and a chest/shoulder protector.

Are You Ready to Ride?

Rider Training

Developing your riding skills is an on-going process. Even if you have ridden other ATVs, take time to become familiar with how this ATV works and handles. Practice riding the ATV in a safe area to build your skills. Do not ride in rough terrain until you get accustomed to the ATV's controls, and feel comfortable with its size and weight.

We urge all riders to take a certified course approved by the ATV Safety Institute (ASI). For information about the ASI training course nearest you, call the national toll-free number; (800) 887-2887 (USA only).

Other riding tips can be found in the *Tips & Practice Guide for the ATV Rider* booklet that came with your ATV (USA only).

WARNING

Operating this ATV without proper instruction could increase your risk of an accident which could lead to serious injury or death.

Beginning and inexperienced operators should complete the certified training course offered by Honda. They should then regularly practice the skills learned in the course and the operating techniques described in the owner's manual.

Are You Ready to Ride?

Age Recommendation

The minimum recommended age for this ATV model is 16. For safety, never let children under 16 years old operate this vehicle.

WARNING

A child using an ATV that is not recommended for their age could lose vehicle control while riding, resulting in severe injury or death.

A child under 16 should never operate an ATV with engine size greater than 90cc.

No Passengers

This ATV is designed as an operator-only vehicle. The long seat is designed to allow the rider to change body position, not for carrying a passenger. Never let a passenger ride on the seat.

WARNING

Carrying a passenger on this ATV greatly reduces your ability to balance and control this ATV and could cause a crash and you or your passenger could be injured or killed.

Never carry a passenger on this ATV.

Are You Ready to Ride?

No Alcohol or Drugs

Alcohol, drugs and ATVs don't mix. Even a small amount of alcohol can impair your ability to operate an ATV safely. Likewise, drugs — even if prescribed by a physician — can be dangerous while operating an ATV. Consult your doctor to be sure it is safe to operate a vehicle after taking medication.

WARNING

Operating this ATV after consuming alcohol or drugs can seriously affect your judgement, cause you to react more slowly, affect your balance and perception, and result in serious injury or death.

Never consume alcohol or drugs before or while operating this ATV.

Is Your ATV Ready to Ride?

Before each ride, it's important to inspect your ATV and make sure any problem you find is corrected. A pre-ride inspection is a must, not only for safety, but because having a breakdown, or even a flat tire, can be a major inconvenience.

If your ATV has overturned or been involved in a collision, do not ride the vehicle until it has been inspected by your Honda dealer. There may be damage or other problems you cannot see.

WARNING

Improperly maintaining this ATV or failing to correct a problem before riding can cause a crash in which you can be seriously hurt or killed.

Always perform a pre-ride inspection before every ride and correct any problems.

Pre-ride Inspection

Check the following items before you get on the ATV:

<i>Engine Oil</i>	Check the level and add oil if needed (page 95). Check for leaks.
<i>Transmission Oil</i>	Check the level and add oil if needed (page 101). Check for leaks.
<i>Radiator Coolant</i>	Check the coolant level and add coolant if needed (page 105). Check for leaks.

Is Your ATV Ready to Ride?

<i>Fuel</i>	Check the level and add fuel (page 90) if needed. Also make sure the fuel fill cap is securely fastened. Check for leaks.
<i>Tires</i>	Use a gauge to check the air pressure. Adjust if needed. Also look for signs of damage or excessive wear (page 143).
<i>Drive Chain</i>	Check the condition and slack. Adjust and lubricate if needed. Also check the chain slider and chain roller for wear and replace if needed (page 151).
<i>Nuts & Bolts</i>	Check the wheels to see that the axle nuts are tightened. Use a wrench to make sure all accessible nuts, bolts, and fasteners are tight.
<i>Underbody & Exhaust System</i>	Check for, and remove, any dirt, vegetation or other debris that could be a fire hazard or interfere with the proper operation of the vehicle.
<i>Leaks, Loose Parts</i>	Walk around your ATV and look for anything that appears unusual, such as a leak or loose cable.
<i>Cable</i>	Check the cable housings for wear. Check the fittings for looseness. Replace or tighten as needed.
<i>Lights</i>	Make sure the headlight, brakelight and taillight are working properly.

Is Your ATV Ready to Ride?

Check these items after you get on the ATV:

Throttle Check the freeplay and adjust if needed. Press the throttle to make sure it moves smoothly without sticking, and snaps shut automatically when it is released, in all steering positions (page 114).

Brakes Squeeze the front brake lever and step on the rear brake pedal to check that the controls operate normally. Make sure there is no brake fluid leakage (page 134).

*Clutch Lever/
Parking Brake
Lever* Check for smooth operation and adjust if needed (page 116).

*Headlight and
Headlight Dimmer
Switch* Check for proper function (page 22).

Engine Stop Switch Check for proper function (page 21).

Steering Check that the wheels turn properly as you steer the handlebar. Move the handlebar right and left and check that there is no excessive backlash.

Remember, be sure to take care of any problem you find, or have your Honda dealer correct it before you ride.

Load Limits & Guidelines

Your Honda was designed as a rider-only ATV. It was not designed to carry a passenger or cargo. A passenger or cargo could interfere with your ability to move around to maintain your balance and control of the ATV.

In addition, exceeding the weight limits or carrying an unbalanced load can seriously affect your ATV's handling, braking and stability. Adding accessories or making modifications that change this ATV's design and performance can also make it unsafe. Also, the weight of any accessories will reduce the maximum load the ATV can carry.

More specific information on load limits, accessories, and modifications follows.

Loading

How much weight you put on your ATV, and how you load it, are important to your safety. If you decide to carry cargo, you should be aware of the following information.

WARNING

Overloading, improper loading, or carrying a passenger can cause a crash and you can be seriously hurt or killed.

Follow all load limits and other loading guidelines in this manual.

Load Limits & Guidelines

Load Limits

Following are the load limits for your ATV:

There is a limit to how much weight can be carried on your ATV.

The following load limit applies to standard equipment only. Modifying your ATV, using non-standard equipment, or riding on terrain that is not flat and smooth could further reduce these limits.

maximum weight capacity 243 lbs (110 kg)
(includes the weight of the rider, all cargo, and accessories.)

The weight of added accessories will reduce the maximum cargo weight you can carry.

Load Limits & Guidelines

Loading Guidelines

As discussed on page 36 , we recommend that you do not carry any cargo on this ATV. However, if you decide to carry cargo, ride at reduced speeds and follow these common-sense guidelines.

Carrying cargo or pulling a trailer will affect how your ATV handles and greatly reduce its ability in accelerating, braking and making turns and other maneuvers.

Be sure to observe the weight limit and follow these guidelines:

- Check that the tires are properly inflated.
- Never ride with a passenger. The ATV is not designed to carry a passenger.
- Do not tow another vehicle.
- Make sure all cargo is secured before riding.
- Never exceed the maximum weight limit.
- Allow extra room for starting, stopping and turning whenever you carry cargo or pull a trailer.
- Avoid riding on steep slopes when carrying cargo or pulling a trailer.
- Never cross a slope when towing a trailer.

Accessories & Modifications

Modifying your ATV or using non-Honda accessories can make your ATV unsafe.

Before you consider making any modifications or adding an accessory, be sure to read the following information.

WARNING

Improper accessories or modifications can cause a crash in which you can be seriously hurt or killed.

Follow all instructions in this owner's manual regarding accessories and modifications.

Accessories

We strongly recommend that you use only Honda Genuine Accessories that have been specifically designed and tested for your ATV. Because Honda cannot test all other accessories, you must be personally responsible for proper selection, installation, and use of non-Honda accessories.

Check with your Honda dealer for assistance and always follow these guidelines:

- Make sure the accessory does not obscure any lights, reduce ground clearance, limit suspension travel or steering travel, or interfere with operating any controls.
- Make sure the accessory does not interfere with your ability to shift body position on the seat or operate hand and foot controls.

(cont'd)

Accessories & Modifications

(TRX450ER)

- Do not add any electrical equipment that will exceed the vehicle's electrical system capacity (page 204). A blown fuse can cause a loss of lights or engine power (page 191).

Modifications

We strongly advise you not to remove any original equipment or modify your ATV in any way that would change its design or operation. Such changes could seriously impair your ATV's handling, stability, and braking, making it unsafe to ride.

We also advise you not to make any modifications or remove any equipment (such as the USDA qualified spark arrester or emission control system components) that would make your ATV illegal in your area.

Removing or modifying your lights, exhaust system, emission control system, or other equipment can also make your ATV illegal.

Basic Operation & Riding

This section gives basic riding instructions, including how to start and stop your engine, how to use the throttle and brakes, and what to do when you're through riding.

To protect your new engine and enjoy optimum performance and service life, refer to Break-in Guidelines (page 205).

For information about carburetor adjustment for riding at high altitude, see page 206.

Safe Riding Precautions	42
Off-Road Use Only	42
Keep Hands and Feet on Controls	43
Control Speed	44
Use Care on Unfamiliar or Rough Terrain	45
Do Not Perform Stunts	46
Starting & Stopping the Engine	47
Preparation	48
Starting Procedure	50
Flooded Engine	54
How to Stop the Engine	55
Shifting Gears	56
Braking	58
Riding Your ATV	60
Making Turns	60
Skidding or Sliding	62
Riding Up Hills	63
Riding Down Hills	67
Crossing or Turning on Hills or Slopes	68
Riding Over Obstacles	70
Riding Through Water	71
Parking	72

Safe Riding Precautions

Before riding your ATV for the first time, please review the *ATV Safety* section beginning on page 1, and the *Before Riding* section beginning on page 27.

Even if you have ridden other ATVs, take time to become familiar with how this ATV works and handles. Practice in a safe area until you build your skills and get accustomed to the ATV's size and weight.

Off-Road Use Only

Your ATV and its tires are designed and manufactured for off-road use only, not for pavement. Riding on pavement can affect handling and control. You should not ride your ATV on pavement.

WARNING

Operating this ATV on paved surfaces may seriously affect handling and control of the ATV, and may cause the vehicle to go out of control.

Never operate the ATV on any paved surfaces, including sidewalks, driveways, parking lots and streets.

When riding off-road, also remember to always obey local off-road riding laws and regulations. Obtain permission to ride on private property. Avoid posted areas and obey “no trespassing” signs.

Safe Riding Precautions

You should never ride your ATV on public streets, roads or highways, even if they are not paved. Drivers of street vehicles may have difficulty seeing and avoiding you, which could lead to a collision. In many states it is illegal to operate ATVs on public streets, roads and highways.

WARNING

Operating this ATV on public streets, roads or highways could cause you to collide with another vehicle.

Never operate this ATV on any public street, road or highway, even a dirt or gravel one.

Keep Hands and Feet on Controls

Always keep both hands on the handlebars and both feet on the footpegs when riding your ATV. This is important to maintain your balance and to control the vehicle. Removing even one hand from the handlebars or one foot from the footpegs can reduce your ability to control the ATV or could cause you to lose your balance and fall off the ATV.

WARNING

Removing hands from handlebars or feet from footpegs during operation can reduce your ability to control the ATV or could cause you to lose your balance and fall off of the ATV.

Always keep both hands on the handlebars and both feet on the footpegs of your ATV during operation.

Safe Riding Precautions

Control Speed

Riding at excessive speed increases the chance of an accident. In choosing a proper speed, you need to consider the capability of your vehicle, the terrain, visibility and other operating conditions, plus your own skills and experience.

WARNING

Operating this ATV at excessive speeds increases your chances of losing control of the ATV, which can result in an accident.

Always go at a speed that is proper for your vehicle, the terrain, visibility and other operating conditions, and your experience.

Safe Riding Precautions

Use Care on Unfamiliar or Rough Terrain

Before riding in a new area, always check the terrain thoroughly. Don't ride fast on unfamiliar terrain or when visibility is limited. (It's sometimes difficult to see obstructions like hidden rocks, bumps, or holes in time to react.)

WARNING

Failure to use extra care when operating this ATV on unfamiliar terrain could result in the ATV overturning or going out of control.

Go slowly and be extra careful when operating on unfamiliar terrain. Always be alert to changing terrain conditions when operating the ATV.

Safe Riding Precautions

Never ride past the limit of visibility. Maintain a safe distance between your ATV and other off-road vehicles. Always exercise caution, and use extra care on rough, slippery and loose terrain.

WARNING

Failure to use extra care when operating on excessively rough, slippery or loose terrain could cause loss of traction or vehicle control, which could result in an accident, including an overturn.

Do not operate on excessively rough, slippery or loose terrain until you have learned and practiced the skills necessary to control the ATV on such terrain. Always be especially cautious on these kinds of terrain.

Do Not Perform Stunts

You should always operate your ATV in a safe and reasonable manner. When riding, always keep all four wheels on the ground.

WARNING

Attempting wheelies, jumps, and other stunts increases the chance of an accident, including an overturn.

Never attempt stunts, such as wheelies or jumps. Don't try to show off.

Starting & Stopping the Engine

Always follow the proper starting procedure described below.

For your safety, avoid starting or operating the engine in an enclosed area such as a garage. Your ATV's exhaust contains poisonous carbon monoxide gas which can collect rapidly in an enclosed area and cause illness or death.

(TRX450ER only)

Your ATV is equipped with a gear position starter cut-off system. The engine cannot be started if the transmission is in gear — unless the clutch lever is pulled in.

Starting & Stopping the Engine

Preparation

(TRX450ER)

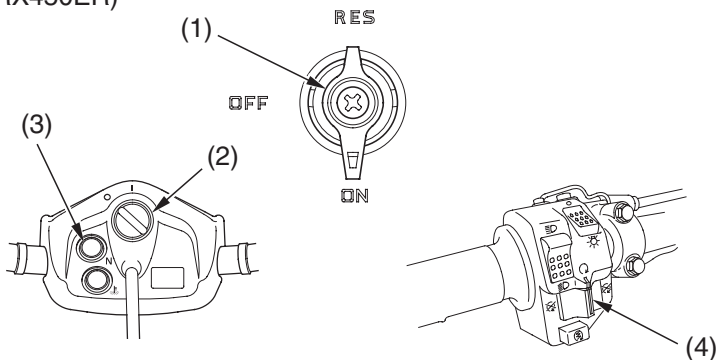

(1) fuel valve

(2) ignition switch

(3) neutral indicator

(4) engine stop switch

1. Before starting, select a level surface and lock the parking brake (page 25).
2. Turn the fuel valve (1) and ignition switch (2) to ON (I).

Confirm the following:

- The transmission is in neutral (neutral indicator (3) ON).
- The engine stop switch (4) is set to RUN (O).

The high coolant temperature indicator should go off a few seconds after the ignition switch to ON (I).

Starting & Stopping the Engine

(TRX450R)

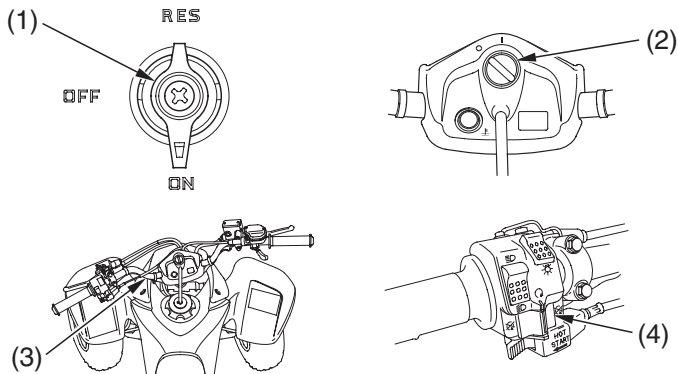

(1) fuel valve

(2) ignition switch

(3) handlebar

(4) engine stop switch

1. Before starting, select a level surface and lock the parking brake (page 25).
2. Turn the fuel valve (1) and ignition switch (2) to ON (I).
3. Turn the handlebar (3) all the way to left.

Confirm the following:

- The transmission is in neutral (the tires roll freely).
- The engine stop switch (4) is set to RUN (O).

The high coolant temperature indicator should go off a few seconds after the engine starts.

Starting & Stopping the Engine

Starting Procedure

The carburetor is equipped with an accelerator pump. Do not open the throttle when starting the engine. This will flood the engine with excess fuel, resulting in hard starting.

NOTICE

Opening the throttle, even slightly, while starting the engine, may cause engine kick-back and engine damage.

To restart a warm engine, follow the procedure for “High Air Temperature.”

(TRX450ER only)

The starter motor will operate when the transmission is in neutral or pull in the clutch lever.

Normal Air Temperature 10° – 35°C (50° – 95°F)

(TRX450ER)

LEFT SIDE

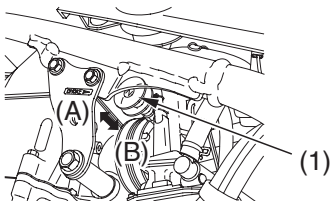

- (1) choke knob
- (2) start button

LEFT HANDLEBAR

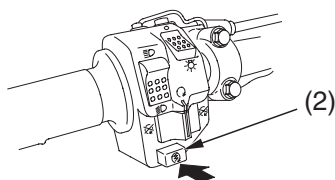

- (A) fully ON
- (B) fully OFF

1. Pull the choke knob (1) left all the way to fully ON (A) position, if the engine is cold.

Starting & Stopping the Engine

2. With the throttle closed, press the start button (2).
- Pressing the electric start button for more than 5 seconds at a time may cause the starter to overheat and damage the starter. Release the start button for approximately 10 seconds before pressing it again.
3. Immediately after the engine starts, operate the choke knob to keep fast idle.
4. About a half minute after the engine starts, push the choke knob right all the way to fully OFF (B).
5. If idling is unstable, open the throttle slightly.

Normal Air Temperature 10° – 35°C (50° – 95°F)

(TRX450R)

LEFT SIDE

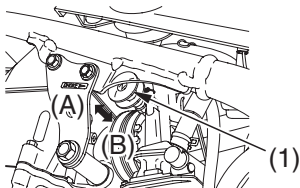

- (1) choke knob
- (2) kickstarter

RIGHT SIDE

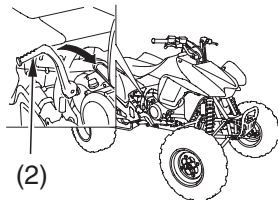

- (A) fully ON
- (B) fully OFF

1. Pull the choke knob (1) left all the way to fully ON (A) position, if the engine is cold.
2. Lightly depress the kickstarter (2) until resistance is felt. Then let kickstarter return to the top of its stroke. With the throttle closed, operate the kickstarter.
3. Immediately after the engine starts, operate the choke knob to keep fast idle.
4. About a half minute after the engine starts, push the choke knob right all the way to fully OFF (B).
5. If idling is unstable, open the throttle slightly.

Starting & Stopping the Engine

High Air Temperature 35°C (95°F) or above
(TRX450ER)

1. Do not use the choke.
2. With the throttle closed, press the start button.

(TRX450R)

1. Do not use the choke.
2. Lightly depress the kickstarter until resistance is felt. Then let kickstarter return to the top of its stroke. With the throttle closed, operate the kickstarter. Kick from the top of the stroke through to the bottom with a rapid, continuous motion. Allowing the kickstarter to snap back freely against the pedal stop can damage the engine case.

Low Air Temperature 10°C (50°F) or below
(TRX450ER & TRX450R)

1. Follow steps 1 – 2 under “*Normal Air Temperature.*”
2. When engine speed begins to pick up, operate the choke knob to keep fast idle.
3. Continue warming up the engine until it runs smoothly and responds to the throttle when the choke knob is fully OFF.

When air temperature is below -15°C (5°F), push the throttle lever eight times to discharge fuel from the accelerator pump into the intake port.

NOTICE

Extended use of the choke may impair piston and cylinder wall lubrication and shorten the life of the engine.

Starting & Stopping the Engine

Warm Engine Starting: (TRX450R only)

LEFT HANDLEBAR

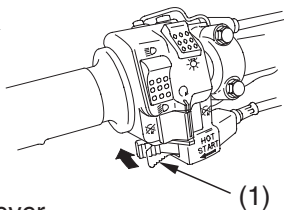

(1) hot start lever

1. Turn the fuel valve ON.
2. Shift the transmission into neutral.
3. Push the hot start lever (1) and kick-start the engine. (Do not open the throttle.)
4. As soon as the engine starts, release the hot start lever.

Starting the engine after a stall during riding or after a fall: (TRX450R only)

1. Shift the transmission into neutral.
2. Push the hot start lever and kick-start the engine (Do not open the throttle).
3. As soon as the engine starts, release the hot start lever.

Starting the engine excessively charged with fuel by throttle blipping or other reasons: (TRX450R only)

1. Shift the transmission into neutral.
2. With the throttle fully opened, repeat kickstarter operation approximately 10 times very slowly to discharge excessive fuel from the engine.
3. Push the hot start lever and kick-start the engine. (Do not open the throttle.)
4. As soon as the engine starts, release the hot start lever.

Starting & Stopping the Engine

Flooded Engine

If the engine fails to start after repeated attempts, it may be flooded with excess fuel. To clear a flooded engine:

(TRX450ER)

1. Move the engine stop switch to OFF (⌘).
2. Push the choke knob right all the way to fully OFF.
3. Open the throttle fully.
4. Press the start button for 5 seconds.
5. Wait 10 seconds, then turn the engine stop switch to RUN (○).
6. Repeat the “*Normal Air Temperature*” starting procedure, but don’t use the choke.

(TRX450R)

1. Push the choke knob right all the way to fully OFF.
2. With the throttle fully opened, repeat kickstarter operation approximately 10 times very slowly to discharge excessive fuel from the engine.
3. Push the hot start lever and kick-start the engine. (Do not open the throttle.)
4. As soon as the engine starts, release the hot start lever.

If the engine still won’t start, refer to *If Your Engine Quits or Won’t Start*, page 183 , 184 .

Starting & Stopping the Engine

How to Stop the Engine

Normal Engine Stop (TRX450ER)

To stop the engine, make sure the transmission is in neutral by checking that the neutral indicator lights, and turn the ignition switch OFF (○).

If your ATV is stopped with the engine stop switch OFF (⌘) and the ignition switch ON (|), the battery will discharge.

(TRX450R)

To stop the engine, make sure the transmission is in neutral, and turn the ignition switch OFF (○).

The engine stop switch should normally remain in the RUN (○) position even when the engine is OFF.

Emergency Engine Stop

To stop the engine in an emergency, use the engine stop switch. To operate, slide the switch to the OFF (⌘) position.

Shifting Gears

GEAR SHIFTING SEQUENCE

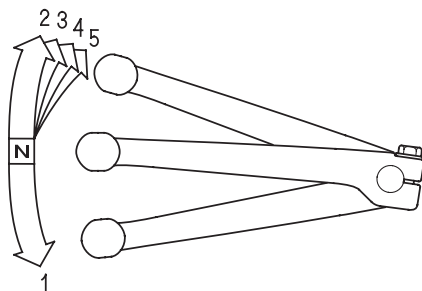

The shift lever is located near the left footpeg. One full stroke of the shift lever shifts the transmission to the next higher or lower gear in the shifting sequence. The shift lever automatically returns to the horizontal position when released.

Your ATV has five forward gears (1, 2, 3, 4 and 5). To shift the transmission, pull in the clutch lever, then operate the shift lever as follows.

To upshift to a higher gear, put the toe of your boot under the shift lever and raise it one full stroke. To downshift, step on the shift lever and depress it one full stroke.

After starting the engine and letting it warm up, follow these procedures:

1. With the transmission in neutral, depress and hold down the rear brake pedal. Release the parking brake (page 25).

Shifting Gears

2. With the throttle closed while the engine is idling, pull in the clutch lever and depress the shift lever to shift into 1st gear.
3. Release the rear brake pedal, gradually release the clutch lever, and increase engine speed by gradually opening the throttle.
4. When the speed increases, close the throttle, pull in the clutch lever, shift to 2nd gear by raising the shift lever, and gradually release the clutch lever while gradually opening the throttle.
5. Repeat this sequence to progressively upshift to 3rd, 4th and 5th (top) gear.
6. To downshift, reverse this sequence. Remember to close the throttle each time you shift to the next lower gear.

Learning when to shift gears comes with experience. Keep the following tips in mind:

- As a general rule, shift while moving in a straight line.
- Close the throttle and pull the clutch lever in completely before shifting. Improper shifting may damage the engine, transmission, and drive train.
- Upshift to a higher gear or reduce throttle before engine rpm (speed) gets too high. Learn the relationship between engine sound and the normal shifting points.
- Downshift to a lower gear before you feel the engine laboring (lugging) at low rpm.
- Avoid downshifting to help slow your ATV when engine rpm is high. Downshifting when engine speed is near its allowable maximum may over-rev the engine and cause possible damage.
- To prevent transmission damage, do not coast or tow the ATV for long distances with the engine off.

Recommended Shift Points

Ride in the highest gear that lets the engine run and accelerate smoothly. This will give you good fuel economy and effective emissions control.

Braking

Your ATV is equipped with disc braking systems which are hydraulically activated. Depressing the brake pedal applies the rear disc brake. Operating the brake lever applies the two front disc brakes.

As a general rule, the front braking system provides about 70 percent of total stopping power.

For full braking effectiveness, use both the pedal and lever simultaneously. Using both braking systems will stop your ATV faster with greater stability.

To slow or stop, apply the brake lever and brake pedal smoothly, while downshifting to match your speed.

Gradually increase braking as you feel the brakes slowing your speed. The increase in engine compression from downshifting will help slow your ATV.

For maximum braking, close the throttle and firmly apply the brake lever and pedal controls.

Applying the brakes too hard may cause the wheels to lock and slide, reducing control of your ATV. If this happens, release the brake controls, steer straight ahead until you regain control, then reapply the brakes more gently.

When possible, reduce your speed or complete braking before entering a turn. Avoid braking or closing the throttle quickly while turning. Either action may cause one or more wheels to slip and reduce your control of your ATV.

Braking

Your ability to brake in a turn and to brake hard in an emergency situation are important riding skills.

When descending a long, steep grade, use engine compression braking by downshifting, with intermittent use of both brakes. Continuous brake application can overheat the brakes and reduce their effectiveness.

To prevent stalling the engine, pull the clutch lever/parking brake lever in before coming to a complete stop.

Riding with your foot resting on the brake pedal or your hand on the brake lever may overheat the brakes, reducing effectiveness.

For information on how to apply the brakes in various riding situations, see the following section, *Riding Your ATV*.

Riding Your ATV

Making Turns

Learn how to turn your ATV properly. Practice the techniques outlined in this section on level ground and at low speeds until you are confident in making turns.

WARNING

Turning improperly can make the ATV go out of control, causing a collision or overturn.

- Always follow proper procedures for turning as described in this owner's manual.
- Practice turning at low speeds before attempting to turn at faster speeds.
- Do not turn at excessive speeds.

Riding Your ATV

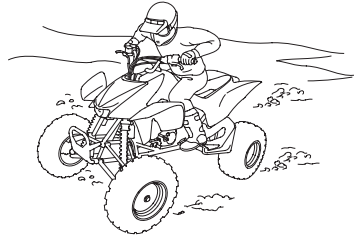
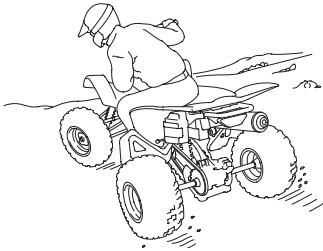

Lean your body to the inside of a turn and forward.

To make a turn on level ground: Steer the handlebar and lean your body toward the inside of the turn. Leaning helps balance the vehicle, and it feels more comfortable. Leaning into a turn is an important technique to master in riding an ATV.

To make a sharp turn at low speed: It helps to shift your body slightly forward on the seat, and lean inside, as you steer the handlebar. Shifting weight forward allows the rear wheels to turn easier, and it also improves front-wheel steering.

To make a turn from a full stop: Apply the throttle gradually when you turn and start up at the same time. Remember to shift your body forward to make sharp low-speed turns and whenever you turn while accelerating from a full stop.

Riding Your ATV

Skidding or Sliding

The terrain surface can be a major factor affecting turns. Skidding during a turn is more likely to occur on slippery surfaces, such as snow, ice, mud and loose gravel. If you skid on ice, you may lose all directional control. To avoid skidding on slippery terrain, keep your speed low and ride with caution.

WARNING

Skidding or sliding improperly may cause you to lose control of this ATV. You may also regain traction unexpectedly, which may cause the ATV to overturn.

Learn to safely control skidding by practicing at low speeds and on level, smooth terrain.

If your ATV skids sideways during a turn, steer in the direction of the skid. Avoid hard braking or accelerating until you have regained directional control.

Riding Your ATV

Riding Up Hills

The ATV's ability to safely climb hills largely depends on the rider's skill and judgment. Begin by practicing on smooth, gentle slopes. As you gain experience, you'll learn the hazards and your own limitations. You may then proceed to ride on more difficult terrain. However, you must be able to decide which hills or hazards might cause the ATV to overturn. Avoid excessively steep hills.

WARNING

Operating on excessively steep hills can cause the vehicle to overturn more easily than operating on level surfaces or small hills.

Never operate the ATV on hills too steep for the ATV or for your abilities.

When climbing hills, you must shift weight toward the front wheels to help keep them on the ground. To do this, shift your body slightly forward on the seat and lean forward. For greater weight shift, move your body farther forward and lean forward.

WARNING

Climbing hills improperly could cause loss of control or cause the ATV to overturn.

Always follow proper procedures for climbing hills as described in this owner's manual.

Riding Your ATV



Shift weight forward when climbing hills.

- Always check the terrain carefully before you start up any hill.
- Never climb hills with excessively slippery or loose surfaces.
- To climb a hill, take a running start in an appropriate gear and speed for the conditions. Maintain a steady speed as you ascend the hill.
- Never open the throttle suddenly or make sudden gear changes. The ATV could flip over backward.
- Never go over the top of any hill at high speed. An obstacle, a sharp drop, or another vehicle or person could be on the other side of the hill.

Riding Your ATV

Stalling the ATV and/or Rolling Backwards:

If you incorrectly estimate climbing capability or terrain conditions, the ATV may not have enough power or traction to continue uphill. If this happens, the ATV can stall and/or roll backwards.

⚠ WARNING

Stalling, rolling backwards or improperly dismounting while climbing a hill could result in the ATV overturning.

Always follow proper procedures for climbing a hill as described in this owner's manual.

What to do if the ATV stalls or rolls backwards when climbing a hill:

If you are about to lose all forward speed:

1. Using the front and rear brakes together, bring the ATV to a stop with the vehicle pointed straight uphill.
2. Get off the ATV while you continue holding the brakes.
3. Shift into neutral, set the parking brake and turn the engine off.
4. Then assess the situation.

If the ATV starts rolling backwards before you begin braking:

1. Keep your weight uphill.
2. Carefully apply the front brakes first, then carefully apply the rear brake. Do not apply either brake abruptly if you are rolling backwards, or the vehicle may overturn.

If the ATV continues sliding backwards:

After you've applied the brakes, get off and away from the vehicle.

Riding Your ATV

What to do after the ATV has stalled or rolled backwards:

If the hill is too steep or too slippery, or if you have any doubt whether you can safely walk the ATV back down the hill, leave the vehicle where it is and get help. If possible, block the wheels so the vehicle doesn't roll backwards.

If the hill is not too steep and you have good footing, you may be able to walk the ATV back down the hill. Make sure your intended path is clear in case you lose control of the ATV.

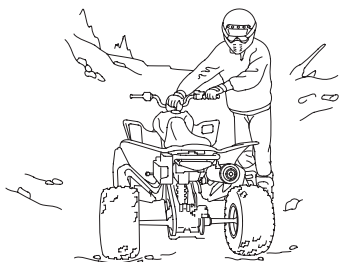

Be sure your legs are clear of the wheels.

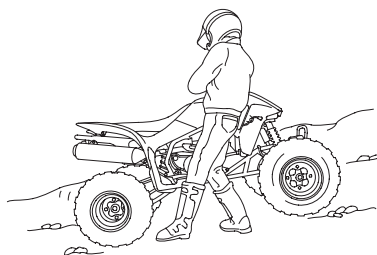

Body position for backing down a hill.

1. Stand with your body facing downhill, beside the vehicle so you can reach the front brake lever with your left hand.
2. Be sure your legs are clear of the wheels.
Check your footing.
3. Slowly and carefully back the ATV down the hill using the front brake lever to control speed.
4. If you lose control of the ATV, for your safety, get away from the vehicle.

Riding Your ATV

Riding Down Hills

It's usually advisable to descend hills with the ATV pointed straight downhill. Avoid angles that would cause the vehicle to lean sharply to one side.

⚠ WARNING

Going down a hill improperly could cause loss of control or cause the ATV to overturn.

Always follow proper procedures for going down hills as described in this owner's manual.

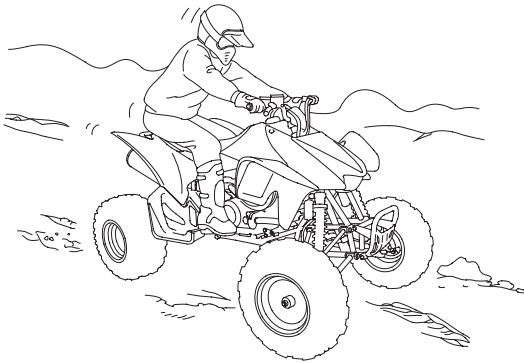

On downhills, shift your weight back.

As you approach a downhill, stop and survey the terrain below. Never ride past the limit of your visibility. Never go down a hill at high speed.

Riding Your ATV

When you've selected a safe downhill path, shift into a lower gear, shift your weight back with your arms extended and braced against the handlebar, then go down slowly with the throttle closed.

Use mainly the rear brake to control speed. Avoid using either the front brake or rear brake hard or abruptly when riding down hills.

Remember, braking effectiveness is reduced on any hill with a loose surface.

Crossing or Turning on Hills or Slopes

Riding on hills or slopes is different from riding on level terrain. Be careful when riding on any hill. Make sure that you practice on gentle, smooth slopes before attempting to ride on steeper or more difficult terrain.

WARNING

Improperly crossing hills or turning on hills could cause loss of control or cause the ATV to overturn.

Always follow proper procedures for crossing or turning on slopes as described in this owner's manual. Avoid crossing steep hills if possible.

Riding Your ATV

Crossing Hills or Slopes

- To maintain balance and stability when riding across a slope, you need to shift weight toward the uphill side of the vehicle. To do this, move your body off the center of the seat and lean toward the uphill side.
- On a slippery or loose surface, you may also need to steer slightly uphill to maintain a straight course across the slope.
- Avoid crossing hills that are excessively steep, slippery or rough.



Shift weight uphill when crossing slopes.

Making Turns on Slopes

- Compared to riding on level ground, you may need to shift more weight and lean more when making turns on slopes.
- Do not make turns on any slopes until you have first mastered the techniques for making turns on level terrain.

Riding Your ATV

Riding Over Obstacles

Before operating in a new area, check for obstacles. Watch out for bumps, rain ruts, potholes and other obstacles in the terrain. When you approach any obstacle, reduce your speed and be prepared to stop. Never try to ride over large obstacles, such as large rocks or fallen logs.

WARNING

Improperly operating over obstacles could cause loss of control or a collision and could cause the ATV to overturn.

When you go over obstacles, always follow proper procedures as described in this owner's manual.

Riding Your ATV

Riding Through Water

Your ATV is designed to travel through water up to approximately 10 inches (254 mm) deep. Before crossing a stream, make sure the water is not too deep or flowing too fast.

WARNING

The ATV tires have some ability to float. Operating this ATV through deep or fast-flowing water may cause a loss of traction and loss of control, which could lead to an accident.

Never operate this ATV in fast-flowing water or in water deeper than that specified in this owner's manual.

1. Choose a path where both banks have gradual slopes.
2. Proceed through the water at a slow, steady speed.
3. Watch out for submerged obstacles and slippery rocks.
4. Avoid getting the spark plug or air cleaner wet, as this would cause the engine to stop.
5. After leaving the water, always test both the front and rear brakes.
 - Riding through water can make the brakes less effective than normal, and may reduce stopping ability.
 - If necessary, apply the brakes repeatedly until they dry out and operate normally.

Parking

1. Look for level parking area. Make sure the ground surface is firm.
2. After bringing your ATV to a stop, hold the brakes while you shift into neutral.
3. Set the parking brake.
4. Turn the ignition switch OFF (\bigcirc).
5. If you're finished riding for the day, turn the fuel valve OFF.

If it is necessary to start the engine when your ATV is stopped on a grade in gear, rock the vehicle back and forth to allow shifting the transmission into neutral.

Parking on a Steep Incline or a Loose or Slippery Surface

If you must park your ATV on a steep incline or loose or slippery surface, use the following procedure:

1. While holding the brakes, set the parking brake.
2. Turn the ignition switch OFF (\bigcirc) and release the brakes.
3. If the ATV begins to move, either while sitting on it or after you dismount, find a better parking location.
4. If rocks or other objects are available, you can block the wheels as shown for additional security.

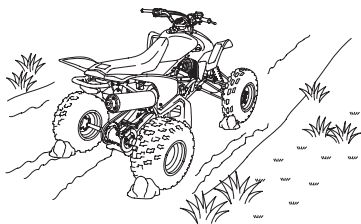
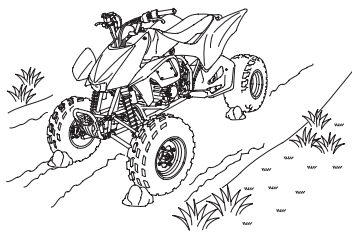

Servicing Your Honda

To help keep your ATV in good shape, this section includes a Maintenance Schedule for required service and step-by-step instructions for specific maintenance tasks. You'll also find important safety precautions, information on fuels and oils, and tips for keeping your Honda looking good.

(TRX450ER only)

For information about replacing the fuse, see page 191 .

For information about the exhaust emission and noise requirements of the U.S. Environmental Protection Agency (EPA), the California Air Resources Board (CARB), and Environment Canada (EC), see page 207 .

USA Only

Maintenance, replacement or repair of the emission control devices and systems may be performed by any ATV repair establishment or individual using parts that are “certified” to EPA standards.

Before You Service Your Honda

The Importance of Maintenance	75
Maintenance Safety	76
Important Safety Precautions	77
Maintenance Schedule	78
Maintenance Record.....	82

Service Preparations

Maintenance Component Locations.....	83
Tool Kit.....	86
Owner's Manual Storage.....	87
Seat Removal	88

(cont'd)

Servicing Your Honda

Service Procedures

Fluids & Filters

Fuel	89
Engine Oil & Filter.....	92
Transmission Oil	99
Coolant.....	104
Air Cleaner.....	110

Engine

Throttle.....	114
Clutch System	116
Engine Idle Speed	120
Spark Plug	121
Valves.....	124
Spark Arrester	125

Chassis

Suspension	127
Brakes.....	133
Tires	143
Engine Guard & Skid Plates.....	150
Drive Chain.....	151

Electrical

Battery (TRX450ER only).....	158
Appearance Care	163

The Importance of Maintenance

A well-maintained ATV is essential for safe, economical, and trouble-free riding. It will also help reduce air pollution. Careful pre-ride inspections and good maintenance are especially important because your ATV is designed to be ridden over rough off-road terrain.

To help you properly care for your ATV, this section of the manual provides a Maintenance Schedule. The service intervals in this schedule are based on average riding conditions.

More frequent service is needed if you subject your ATV to severe use or ride in unusually wet or dusty areas.

WARNING

Improperly maintaining this ATV or failing to correct a problem before you ride can cause a crash in which you can be seriously hurt or killed.

Always follow the inspection and maintenance recommendations and schedules in this owner's manual.

Frequent servicing of the air cleaner is especially important to help you avoid a possible costly engine repair.

If your ATV overturns or is involved in a crash, be sure your Honda dealer inspects all major parts, even if you are able to make some repairs.

Maintenance Safety

This section includes instructions on how to perform some important maintenance tasks. If you have basic mechanical skills, you can perform many of these tasks with the tools provided with your ATV.

Other tasks that are more difficult and require special tools are best performed by professionals. Removing the wheels should normally be handled only by a Honda technician or other qualified mechanic. Instructions are included in this manual only to assist in emergency service.

Some of the most important safety precautions follow. However, we cannot warn you of every conceivable hazard that can arise in performing maintenance. Only you can decide whether or not you should perform a given task.

WARNING

Failure to properly follow maintenance instructions and precautions can cause you to be seriously hurt or killed.

Always follow the procedures and precautions in this owner's manual.

Maintenance Safety

Important Safety Precautions

- Make sure the engine is off before you begin any maintenance or repairs. This will help eliminate several potential hazards:
 - Carbon monoxide poisoning from engine exhaust.** Be sure there is adequate ventilation whenever you operate the engine.
 - Burns from hot ATV parts.** Let the engine and exhaust system cool before touching.
 - Injury from moving parts.** Do not run the engine unless instructed to do so.
- Read the instructions before you begin, and make sure you have the tools and skills required.
- To reduce the possibility of a fire or explosion, be careful when working around gasoline. Use only non-flammable solvent, not gasoline, to clean parts. Keep cigarettes, sparks, and flames away from all fuel-related parts.

Remember that your Honda dealer knows your ATV best and is fully equipped to maintain and repair it. To ensure the best quality and reliability, use only new Honda Genuine Parts or other equivalents for repair and replacement. If you have the tools and skills required for additional maintenance jobs, you can purchase an official Honda Service Manual (page 214).

Maintenance Schedule

The required Maintenance Schedule that follows specifies how often you should have your ATV serviced, and what things need attention. It is essential to have your ATV serviced as scheduled to maintain safe, dependable performance and proper emission control.

The service intervals in this Maintenance Schedule are based on average riding conditions. Some items will need more frequent service if you ride in unusually wet or dusty areas or at full throttle. Consult your Honda dealer for recommendations applicable to your individual needs and use.

Some items in the Maintenance Schedule can be performed with basic mechanical skills and hand tools. Procedures for these items are provided in this manual. Other items involve more extensive procedures and may require special training, tools, and equipment. We recommend that you have your Honda dealer perform these tasks unless you have advanced mechanical skills and the required tools and equipment. Procedures for such items in this schedule are provided in an official Honda Service Manual available for purchase (page 214).

If you do not feel capable of performing a given task or need assistance, remember that your Honda dealer knows your ATV best and is fully equipped to maintain and repair it. If you decide to do your own maintenance, use only Honda Genuine Parts or their equivalents for repair or replacement to ensure the best quality and reliability.

Maintenance Schedule

Perform the pre-ride inspection (page 33) and owner maintenance on this section at each scheduled maintenance period.

Each item on the maintenance schedule requires some mechanical knowledge. Certain items (particularly those marked * and **) may require more technical information and tools. Consult your Honda dealer.

- * Should be serviced by your Honda dealer, unless you have the proper tools and service data and are mechanically qualified. Refer to the official Honda Service Manual (page 214).
- ** In the interest of safety, we recommend these items be serviced only by your Honda dealer.

Summary of Maintenance Schedule Notes & Procedures:

NOTES:

1. Service more frequently when riding in dusty areas, sand or snow.
2. Service more frequently after riding in very wet or muddy conditions.
3. Replace every 2 years. Replacement requires mechanical skill.

Maintenance Schedule

Maintenance Procedures:

I: inspect and clean, adjust, lubricate, or replace, if necessary

C: clean

A: adjust

L: lubricate

R: replace

ITEMS	FREQUENCY	WHICHEVER COMES FIRST ⇔ NOTE	INITIAL MAINT.		REGULAR MAINT. INTERVAL		Refer to page
			mi	100	600	1200	
			km	150	1000	2000	
* FUEL LINE					I		—
* THROTTLE OPERATION					I		114
AIR CLEANER		NOTE 1			C	C	110
SPARK PLUG						I	121
* VALVE CLEARANCE/ DECOMPRESSOR SYSTEM			I	I	I		124
ENGINE OIL			INITIAL= 100 mi (150 km), 20 operating hours or 1 month: R REGULAR= Every 600 mi (1,000 km), 100 operating hours or 12 months: R				92
ENGINE OIL FILTER			R	R	R		96
* TRANSMISSION OIL				R	R		99
* ENGINE IDLE SPEED			I	I	I		120
RADIATOR COOLANT		NOTE 3			I	I	104
* COOLING SYSTEM		NOTE 2			I	I	105

* Should be serviced by your Honda dealer, unless you have the proper tools and service data and are mechanically qualified. Refer to the official Honda Service Manual (page 214).

Maintenance Schedule

ITEMS	FREQUENCY	WHICHEVER COMES FIRST	INITIAL MAINT.	REGULAR MAINT. INTERVAL		Refer to page	
		⇔	mi	600	1200		
			km	150	1000		2000
		NOTE	HOURS	20	100		200
	DRIVE CHAIN	NOTE 1,2		I, L	I, L EVERY 300 mi (500 km) or 50 operating hours		151
	DRIVE CHAIN SLIDER			I	I	153	
*	BRAKE FLUID	NOTE 3		I	I	133	
*	BRAKE PADS WEAR	NOTE 1,2			I	137	
*	BRAKELIGHT SWITCH			I	I	140	
	BRAKE SYSTEM			I	I	133	
	SKID PLATES, ENGINE GUARD			I	I	150	
*	CLUTCH SYSTEM			I	I	116	
*	SUSPENSION			I	I	127	
*	SPARK ARRESTER			C	C	125	
*	NUTS, BOLTS, FASTENERS			I	I	—	
**	WHEELS/TIRES			I	I	—	
**	TIE-ROD AND JOINT BOOTS			I	I	—	
**	STEERING SHAFT HOLDER BEARINGS				I	—	
**	STEERING SYSTEM				I	—	

* Should be serviced by your Honda dealer, unless you have the proper tools and service data and are mechanically qualified. Refer to the official Honda Service Manual (page 214).

** In the interest of safety, we recommend these items be serviced only by your Honda dealer.

Maintenance Record

Keeping an accurate maintenance record will help ensure that your ATV is properly maintained. Retain detailed receipts to verify the maintenance was performed. If the ATV is sold, these receipts should be transferred with the ATV to the new owner. Make sure whoever performs the maintenance completes this record. All scheduled maintenance, including the 100 mile (150 km) or 20 hours initial maintenance, is considered a normal owner operating cost and will be charged for by your dealer. Use the space under Notes to record anything you want to remind yourself about or mention to your dealer.

Miles (km) or hours	Date	Performed By:	Notes
100 (150) or 20			
600 (1,000) or 100			
1,200 (2,000) or 200			
1,800 (3,000) or 300			
2,400 (4,000) or 400			
3,000 (5,000) or 500			
3,600 (6,000) or 600			
4,200 (7,000) or 700			
4,800 (8,000) or 800			

Maintenance Component Locations

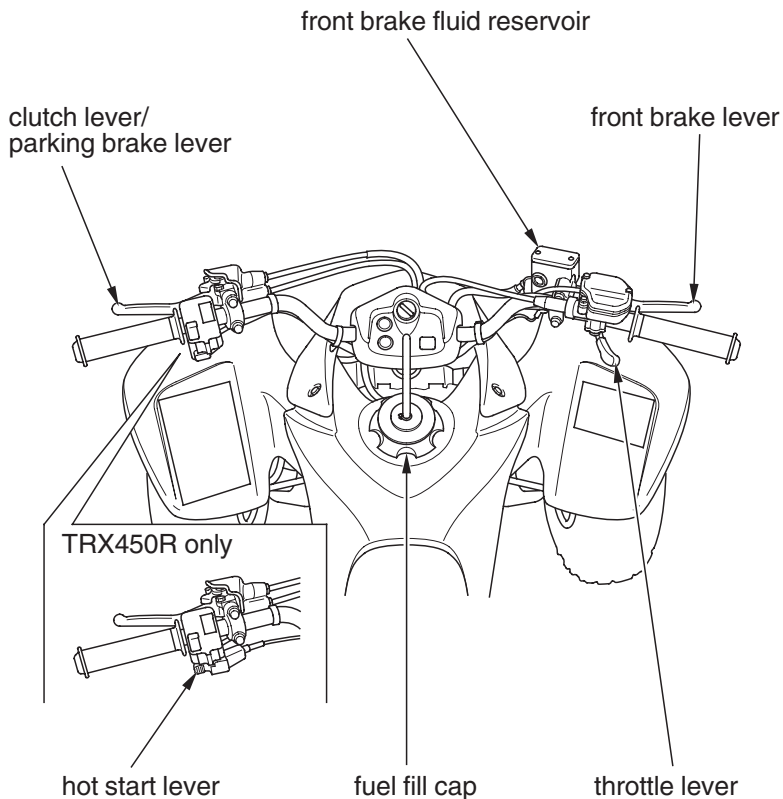

Maintenance Component Locations

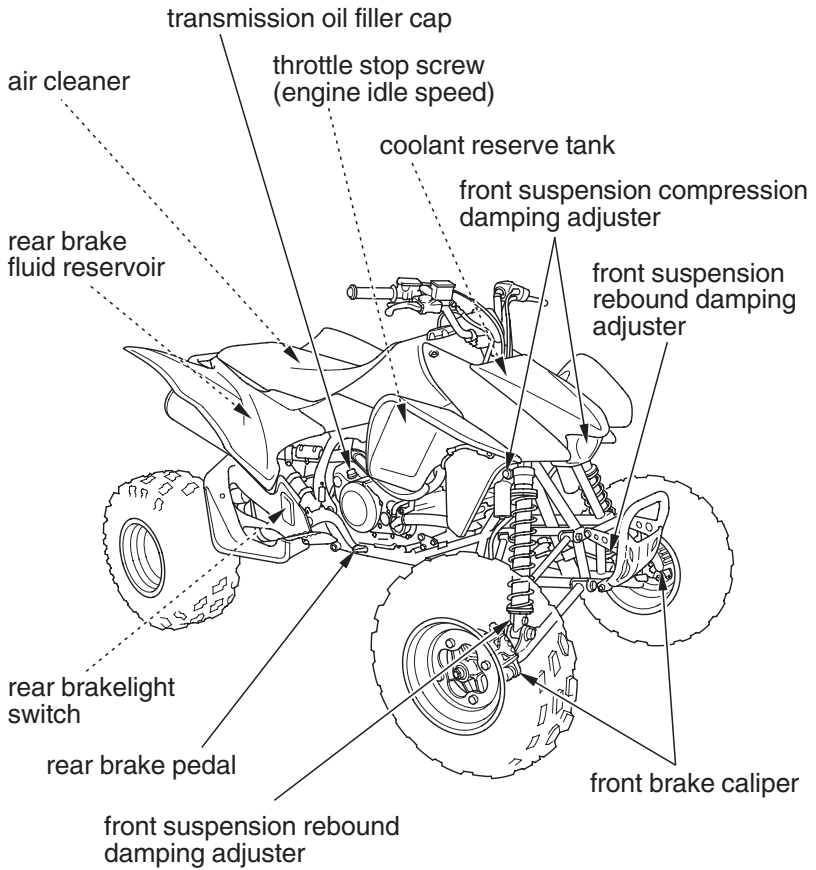

Maintenance Component Locations

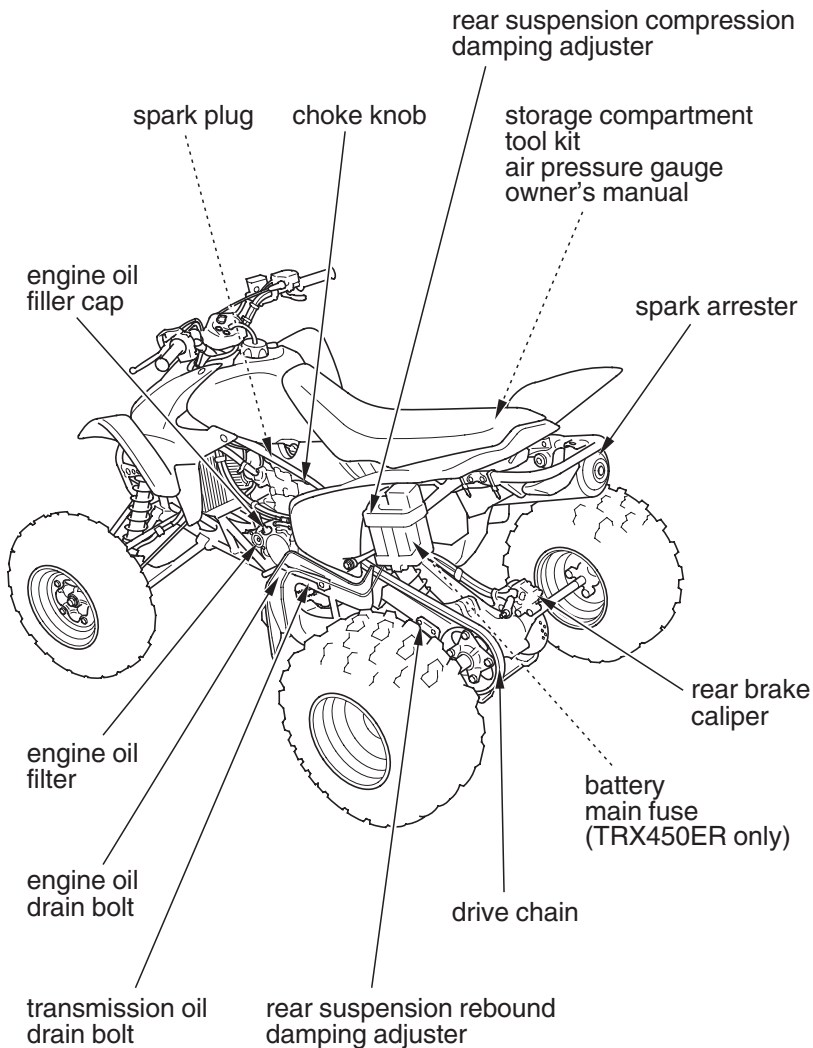

Tool Kit

The tool kit (1) is stored in the storage compartment (2) under the seat. After using the tools, be sure to use the rubber band (3) to fasten the tool kit securely.

To access the tool kit, remove the seat (see page 88), and then remove the rubber band.

An optional, larger tool kit may be available. Check with your Honda dealer's parts department.

UNDER SEAT

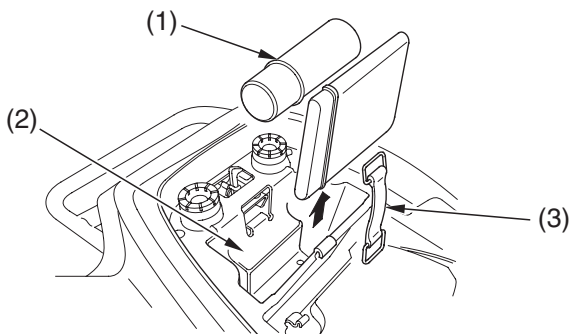

(1) tool kit
(2) storage compartment

(3) rubber band

Owner's Manual Storage

Your ATV provides storage for the owner's manual so you'll have it with you for easy reference. Store your owner's manual (1) in the storage compartment (2) under the seat.

To access the owner's manual, remove the seat (see page 88), then remove the rubber band (3), and open the plastic cover (4).

Make sure the owner's manual and tool kit are fastened securely with the rubber band.

Be careful not to flood this area when washing your ATV.

REAR

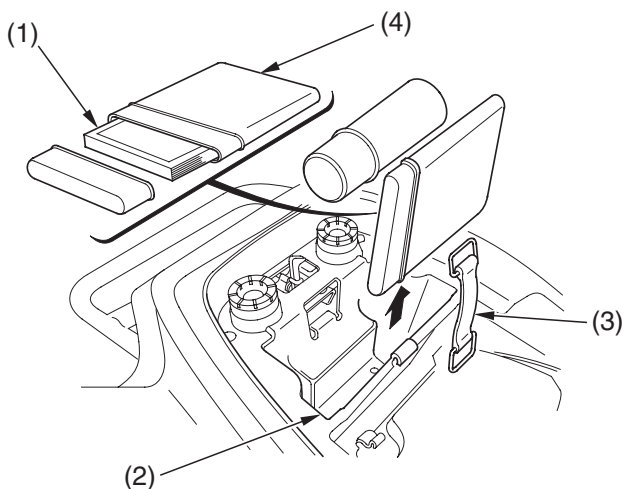

- (1) owner's manual
- (2) storage compartment

- (3) rubber band
- (4) plastic cover

Seat Removal

Refer to *Safety Precautions* on page 77 .

The seat must be removed for the air cleaner maintenance, and access to the tool kit and owner's manual.

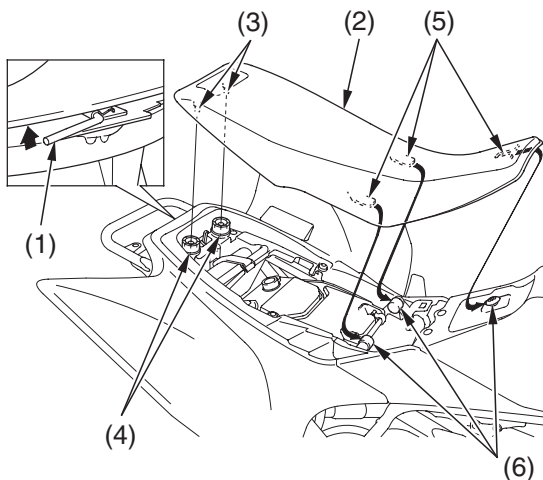

- (1) seat lock lever
- (2) seat
- (3) studs

- (4) grommets
- (5) front prongs
- (6) hooks

Removal

1. Pull the seat lock lever (1) up below the rear end of the seat.
2. Pull the seat (2) up from the rear to remove the studs (3) from the grommets (4).
3. Slide the seat back and up.

Installation

1. Insert the front prongs (5) into the hooks (6) on the frame and press the studs into the grommets.
2. Press down on the seat until it locks.

Refer to *Safety Precautions* on page 77 .

Fuel Recommendation

type	premium unleaded
pump octane number	91 (or higher)

We recommend that you use premium unleaded fuel because it produces fewer engine deposits and extends the life of exhaust system components.

Your engine is designed to use any premium gasoline that has a pump octane number of 91 or higher. Gasoline pumps at service stations normally display the pump octane number. For information on the use of oxygenated fuels, see page 211 .

Use of lower octane gasoline can cause persistent “pinging” or “spark knock” (a loud rapping noise) which, if severe, can lead to engine damage. Light pinging experienced while operating under a heavy load, such as climbing a hill, is no cause for concern.

If pinging or spark knock occurs at a steady engine speed under normal load, change brands of gasoline. If pinging or spark knock persists, consult your Honda dealer.

Never use stale or contaminated gasoline or an oil/gasoline mixture. Avoid getting dirt, dust, or water in the fuel tank.

Fuel

Fuel Capacity

Fuel tank capacity, including reserve:

2.72 US gal (10.3 ℓ)

Reserve capacity:

0.79 US gal (3.0 ℓ)

The tank should be refilled as soon as possible after switching to reserve, and the fuel valve should be returned to the ON position after refueling to avoid running out of fuel with no reserve.

Refueling Procedure

Refer to *Safety Precautions* on page 77 .

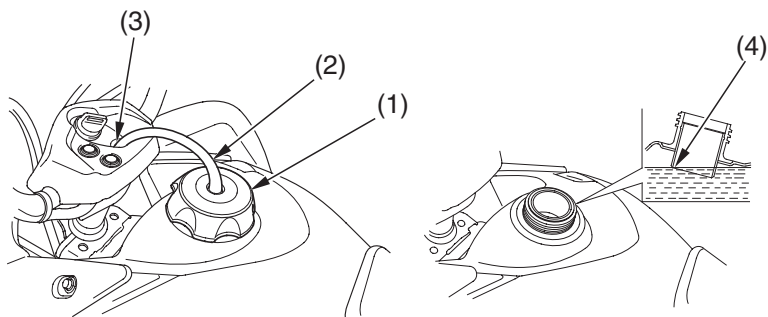

- (1) fuel fill cap
- (2) breather tube

- (3) handlebar cover hole
- (4) filler neck

1. To open the fuel fill cap (1), turn it counterclockwise.
2. Pull the breather tube (2) out of the handlebar cover hole (3).
3. Add fuel until the level reaches the bottom of the filler neck (4).

Avoid over filling the tank. There should be no fuel in the filler neck.

WARNING

Gasoline is highly flammable and explosive. You can be burned or seriously injured when handling fuel.

- Stop the engine and keep heat, sparks and flame away.
- Handle fuel only outdoors.
- Wipe up spills immediately.

4. After refueling, turn the fuel fill cap clockwise.
5. Insert the breather tube into the handlebar cover hole.
6. If the fuel valve was set to RES, turn the fuel valve ON.

If you replace the fuel fill cap, use only a Honda Genuine replacement part.

Engine Oil & Filter

Engine oil quality is a major factor that affects both the performance and the service life of the engine.

Using the proper oil (page 93) and filter, and regularly checking, adding, and changing oil will help extend your engine's life. Even the best oil wears out. Changing oil helps get rid of dirt and deposits in the engine. Operating the engine with old or dirty oil can damage your engine. Running the engine with insufficient oil can cause serious damage to the engine and transmission.

Change the engine oil as specified in the maintenance schedule on page 80 . When running in very dusty conditions, oil changes should be performed more frequently than specified in the maintenance schedule.

Engine Oil & Filter

Engine Oil Recommendation

API classification	SG or higher except oils labeled as energy conserving on the circular API service label
viscosity (weight)	SAE 10W-30
JASO T 903 standard	MA
suggested oil*	Pro Honda GN4 4-stroke oil (USA & Canada), or Honda 4-stroke oil (Canada only), or an equivalent motorcycle oil.

* Suggested oils are equal in performance to SJ oils that are not labeled as energy conserving on the circular API service label.

- Your ATV does not need oil additives. Use the recommended oil.
- Do not use API SH or higher oils displaying a circular API “energy conserving” service label on the container. They may affect lubrication.



NOT RECOMMENDED



OK

- Do not use non-detergent, vegetable, or castor based racing oils.

Engine Oil & Filter

Other viscosities shown in the following chart may be used when the average temperature in your riding area is within the indicated range.

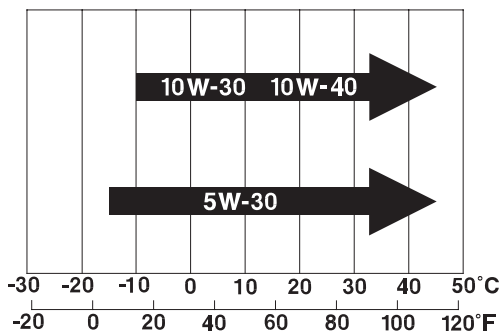

JASO T 903 standard

The JASO T 903 standard is an index for engine oils for 4-stroke motorcycle engines.

There are two classes: MA and MB.

Oil conforming to the standard is labeled on the oil container. For example, the following label shows the MA classification.

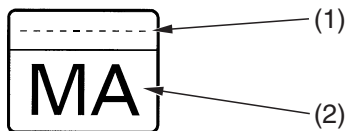

PRODUCT MEETING JASO T 903
COMPANY GUARANTEEING THIS MA PERFORMANCE:

- (1) code number of the sales company of the oil
- (2) oil classification

Engine Oil & Filter

Checking & Adding Engine Oil

Refer to *Safety Precautions* on page 77.

Check the engine oil level each day before operating your ATV and add if needed.

Before riding your ATV, check the engine oil level.

1. Park your ATV on a firm, level surface.
2. Start the engine in a well-ventilated area and let it idle for 3–5 minutes. Stop the engine and wait 2–3 minutes.
3. Check that the engine oil level is between the upper (1) and lower (2) level marks in the inspection window (3) located on the left side of the crankcase cover.
4. If required, remove the engine oil filler cap (4) from the left side of the crankcase and add the specified oil into the filler cap hole, up to the upper level mark in the inspection window. Do not overfill.
5. Reinstall the engine oil filler cap. Check for oil leaks.

NOTICE

Running the engine with an improper oil level can cause serious engine damage.

LEFT SIDE

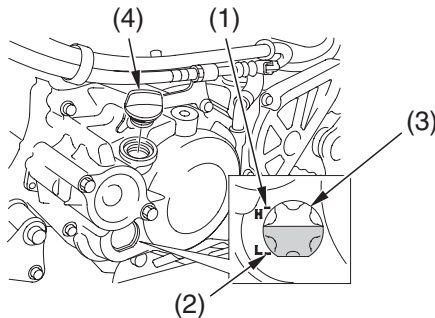

(1) upper level mark (H)

(2) lower level mark (L)

(3) inspection window

(4) engine oil filler cap

Engine Oil & Filter

Changing Engine Oil & Filter

Refer to *Safety Precautions* on page 77.

Your ATV's oil filter has very specific performance requirements. Use a new Honda Genuine oil filter specified for your model or a filter of equal quality.

NOTICE

Using the wrong oil filter may result in leaks or premature engine damage.

This procedure requires mechanical skill and professional tools such as a torque wrench, as well as a means for disposing of the drained fluid (page 178). If you do not have the skills or the tools, see your Honda dealer.

Drain the Engine Oil:

1. Start the engine in a well-ventilated area and let it idle for 3–5 minutes. Stop the engine and wait 2–3 minutes.
2. With the ATV on level ground, remove the engine oil filler cap from the left side of the crankcase cover.
3. Place an oil drain pan under the crankcase and remove the engine oil drain plug (1) and sealing washer (2).

UNDER ENGINE

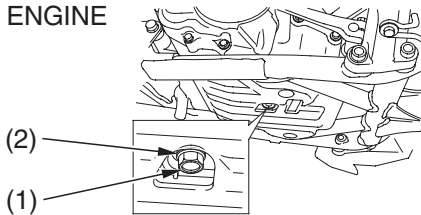

(1) engine oil drain plug

(2) sealing washer

Engine Oil & Filter

Install a New Engine Oil Filter:

1. Remove the oil filter cover (1) by removing the bolts (2). Let the remaining oil drain out. Discard the oil filter (3) in an approved manner (page 178).
2. Check that the oil filter cover O-ring (4) is in good condition and then install a new oil filter. Use only the Honda Genuine oil filter or a filter of equivalent quality specified for your model. Using the wrong Honda filter or a non-Honda filter which is not of equivalent quality may cause engine damage.
3. Reposition the spring (5) to the engine crankcase and install a new oil filter with the rubber seal (6) facing out, away from the engine. You will see the “OUTSIDE (TOWARDS FILTER COVER)” mark (7) on the filter body, near the seal.

NOTICE

Proper installation of the oil filter can cause serious engine damage.

LEFT SIDE

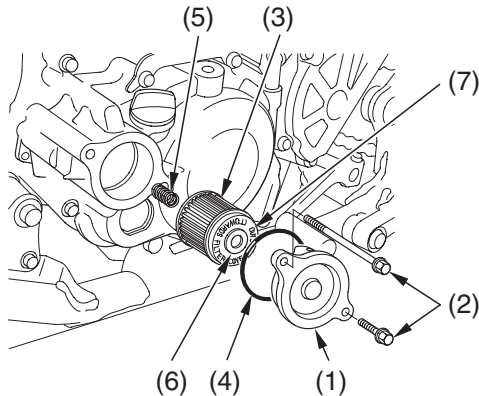

- (1) oil filter cover
- (2) bolts
- (3) oil filter
- (4) O-ring

- (5) spring
- (6) rubber seal
- (7) OUTSIDE mark

(cont'd)

Engine Oil & Filter

4. Reinstall the oil filter cover, making sure the bolts are tightened to the specified torque:
9 lbf·ft (12 N·m , 1.2 kgf·m)
5. Pour the drained oil into a suitable container and dispose of it in an approved manner (page 178).

NOTICE

Improper disposal of drained fluids is harmful to the environment.

Add Engine Oil:

1. Check that the drain plug sealing washer is in good condition. If necessary, replace the sealing washer.
2. Reinstall the engine oil drain plug and tighten it to the specified torque:
18 lbf·ft (25 N·m , 2.5 kgf·m)
3. Fill the crankcase with the recommended grade oil approximately:
0.73 US qt (0.69 ℓ)
4. Reinstall the engine oil filler cap.
5. Start the engine and let it idle for 3 – 5 minutes.
6. Stop the engine, wait 2 – 3 minutes and check the engine oil level. Make sure the engine oil level is at the upper level mark in the inspection window with the ATV upright on firm, level ground. If necessary, add more oil but do not overfill.
7. Check that there are no oil leaks.

If a torque wrench is not used for installation, see your Honda dealer as soon as possible to verify proper assembly.

Transmission Oil

Transmission Oil Recommendation

API classification	SG or higher except oils labeled as energy conserving on the circular API service label
viscosity (weight)	SAE 10W-30
JASO T 903 standard	MA
suggested oil*	Pro Honda HP Trans Oil, Pro Honda GN4 4-stroke oil or an equivalent.

* Suggested oils are equal in performance to SJ oils that are not labeled as energy conserving on the circular API service label.

- Your ATV does not need oil additives. Use the recommended oil.
- Do not use oils with graphite or molybdenum additives. They may adversely affect clutch operation.
- Do not use API SH or higher oils displaying a circular API “energy conserving” service label on the container. They may affect lubrication and clutch performance.



NOT RECOMMENDED



OK

- Do not use non-detergent, vegetable, or castor based racing oils.

Transmission Oil

Other viscosities shown in the following chart may be used when the average temperature in your riding area is within the indicated range.

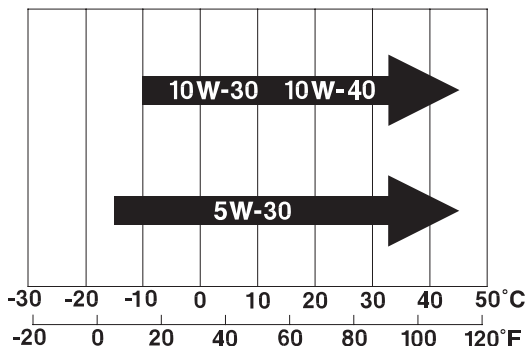

JASO T 903 standard

The JASO T 903 standard is an index for engine oils for 4-stroke motorcycle engines.

There are two classes: MA and MB.

Oil conforming to the standard is labeled on the oil container. For example, the following label shows the MA classification.

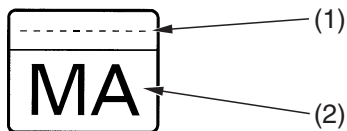

PRODUCT MEETING JASO T 903
COMPANY GUARANTEEING THIS MA PERFORMANCE:

- (1) code number of the sales company of the oil
- (2) oil classification

Transmission Oil

Checking & Adding Transmission Oil

Refer to *Safety Precautions* on page 77.

Check the transmission oil level each day before operating your ATV and add if needed.

1. Park your ATV on a firm, level surface.
2. Start the engine in a well-ventilated area and let it idle for 3–5 minutes. Stop the engine and wait 2–3 minutes to allow the oil to properly distribute itself in the clutch and transmission.
3. Remove the transmission oil filler cap (1) and oil check bolt (2) from the right crankcase cover.

A small amount of oil should flow out of the oil check bolt hole. If no oil flows out of the oil check bolt hole, add transmission oil slowly through the transmission oil filler hole until oil starts to flow out of the oil check bolt hole. Install the oil check bolt and transmission oil filler cap.

4. After inspecting the transmission oil level or adding oil, tighten the oil check bolt and tighten it to the specified torque:

9 lbf·ft (12 N·m , 1.2 kgf·m)

5. Install the transmission oil filler cap.

NOTICE

Running the engine with an improper oil level can cause serious engine damage.

RIGHT SIDE

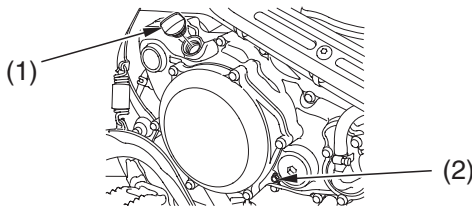

(1) transmission oil filler cap

(2) oil check bolt

Transmission Oil

Changing Transmission Oil

Refer to *Safety Precautions* on page 77.

Drain the Transmission Oil:

1. Start the engine in a well-ventilated area and let it idle for 3–5 minutes. Stop the engine and wait 2–3 minutes.
2. With the ATV on level ground, remove the transmission oil filler cap from the right crankcase cover.
3. Place an oil drain pan under the crankcase and remove the transmission oil drain plug (1) and sealing washer (2).
4. Pour the drained oil into a suitable container and dispose of it in an approved manner (page 178).

NOTICE

Improper disposal of drained fluids is harmful to the environment.

LEFT SIDE CRANKCASE

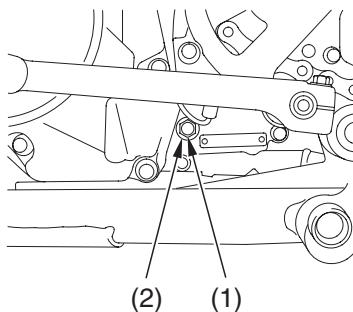

(1) transmission oil drain plug (2) sealing washer

Transmission Oil

Add Transmission Oil:

5. Check that the transmission oil drain plug sealing washer is in good condition. If necessary, replace the sealing washer.
6. Reinstall the transmission oil drain plug and tighten it to the specified torque:
16 lbf·ft (22 N·m , 2.2 kgf·m)
7. Fill the crankcase with the recommended grade oil approximately:
0.72 US qt (0.68 ℓ)
8. Reinstall the transmission oil filler cap.
9. Start the engine and let it idle for 3—5 minutes. Stop the engine, wait 2—3 minutes to allow the oil to properly distribute itself in the clutch and transmission. Check the transmission oil level by following the steps in *Checking & Adding Transmission Oil* (see page101).
10. Check that there are no oil leaks.

If a torque wrench is not used for installation, see your Honda dealer as soon as possible to verify proper assembly.

Coolant

Your ATV's liquid cooling system dissipates engine heat through the coolant jacket that surrounds the cylinder and cylinder head.

Maintaining the coolant will allow the cooling system to work properly and prevent freezing, overheating, and corrosion.

Coolant Recommendation

Use Pro Honda HP coolant or an equivalent high quality ethylene glycol antifreeze containing corrosion protection inhibitors specifically recommended for use in aluminum engines. Check the antifreeze container label.

Use only distilled water as a part of the coolant solution. Water that is high in mineral content or salt may be harmful to the aluminum engine.

NOTICE

Using coolant with silicate inhibitors may cause premature wear of water pump seals or blockage of radiator passages. Using tap water may cause engine damage.

The factory provides a 50/50 solution of antifreeze and water in this ATV. This coolant solution is recommended for most operating temperatures and provides good corrosion protection.

Decreasing the concentration of antifreeze to less than 40% will not provide proper corrosion protection.

Coolant

Increasing the concentration of antifreeze is not recommended because it decreases cooling system performance. Higher concentrations of antifreeze (up to 60%) should only be used to provide additional protection against freezing. Check the cooling system frequently during freezing weather.

Checking & Adding Coolant

Refer to *Safety Precautions* on page 77.

Check the engine coolant level each day before operating your ATV and add if needed.

RIGHT FRONT

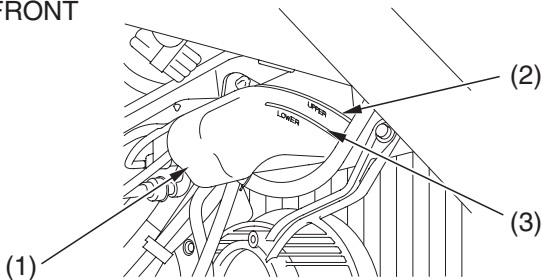

(1) reserve tank
(2) UPPER level mark

(3) LOWER level mark

1. Make sure the vehicle is on level ground.
2. With the engine at normal operating temperature, check the coolant level in the reserve tank (1). It should be between the UPPER (2) and LOWER (3) level marks.

If the reserve tank is empty, or if coolant loss is excessive, check for leaks and see your Honda dealer for repair.

(cont'd)

Coolant

3. Remove the steering cover (4) and reserve tank cap (5).
Always add coolant to the reserve tank. Do not attempt to add coolant by removing the radiator cap.
4. Add coolant to the reserve tank as required to bring the coolant level to the UPPER level mark.

FRONT

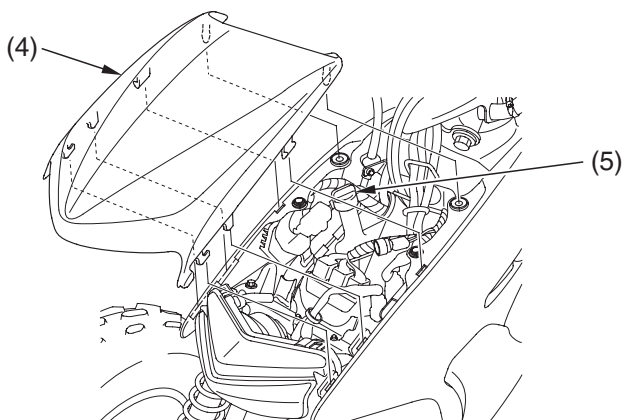

(4) steering cover

(5) reserve tank cap

5. After adding coolant, install the reserve tank cap and steering cover.

Coolant Replacement

Refer to *Safety Precautions* on page 77 .

Coolant should be replaced by your Honda dealer, unless you have the proper tools and service data and are mechanically qualified. Refer to the official Honda Service Manual (page 214).

WARNING

Removing the radiator cap while the engine is hot can cause the coolant to spray out, seriously scalding you.

Always let the engine and radiator cool down before removing the radiator cap.

To properly dispose of drained coolant, refer to *You & the Environment*, page 178 .

NOTICE

Improper disposal of drained fluids is harmful to the environment.

Coolant

Radiator Core

Refer to *Safety Precautions* on page 77 .

Check the air passages for clogging or damage. Remove insects, mud, or any obstruction with low water pressure. Have the radiator checked by your Honda dealer if the air flow is restricted over more than 20% of the radiator surface.

Clean the radiator core after riding the ATV in mud.

To clean the radiator core and radiator grill:

1. Remove the steering cover (page 106).
2. Remove the shroud (1) by removing the bolts A (2) and B (3), the clip (4), and the grommets (5) from the prongs.
3. The right and left shrouds can be removed in the same manner.

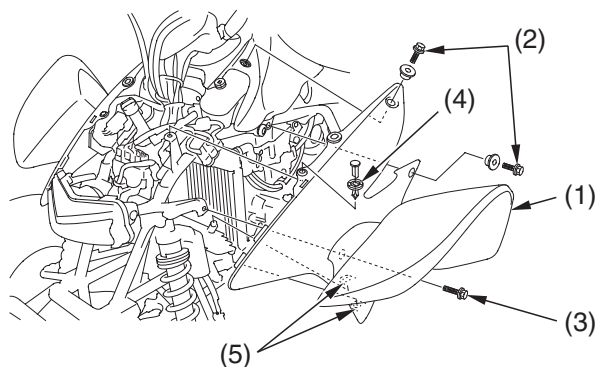

(1) shroud

(2) bolts A

(3) bolt B

(4) clip

(5) grommets

Coolant

4. Remove the radiator grill (6) from the frame.
5. Wash the radiator grill and radiator core (7).

NOTICE

High pressure water (or air) can damage the radiator core.

LEFT SIDE

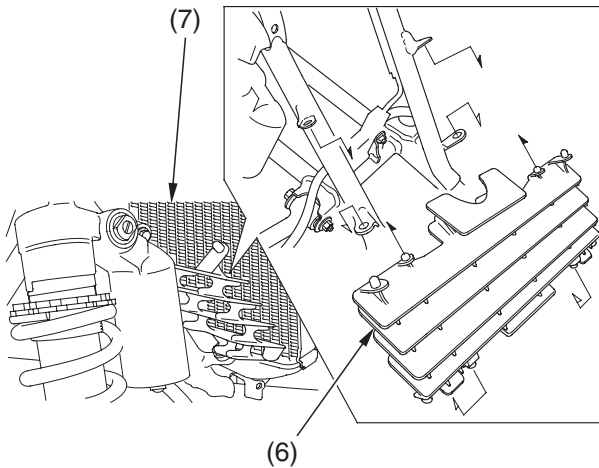

(6) radiator grill

(7) radiator core

6. Install the radiator grill, right and left shrouds and steering cover in the reverse order of removal.

Air Cleaner

Refer to *Safety Precautions* on page 77 .

Proper air cleaner maintenance is very important for off-road vehicles. A dirty, water-soaked, worn-out, or defective air cleaner will allow dirt, dust, mud, and other impurities to pass into the engine.

Service the air cleaner more frequently if you ride in unusually wet or dusty areas. Your Honda dealer can help you determine the correct service interval for your riding conditions.

Your ATV's air cleaner has very specific performance requirements. Use a new Honda Genuine air cleaner specified for your model or an air cleaner of equal quality.

NOTICE

Using the wrong air cleaner may result in premature engine damage.

Proper air cleaner maintenance can prevent premature engine wear or damage, expensive repairs, low engine power, poor gas mileage, and spark plug fouling.

NOTICE

Improper or lack of proper air cleaner maintenance can cause poor performance and premature engine wear.

Air Cleaner

Cleaning

UNDER SEAT

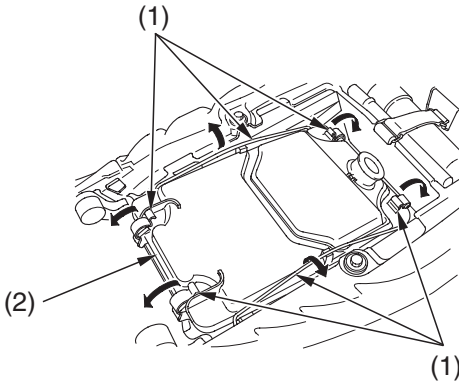

(1) retainer clips

(2) air cleaner housing cover

1. Remove the seat (page 88).
2. Unlatch the retainer clips (1).
3. Remove the air cleaner housing cover (2).

(cont'd)

Air Cleaner

4. Remove the screw A (3) and stay (4).
5. Loosen the screw B (5) and remove the air cleaner assembly (6) from the air cleaner housing.
6. Unscrew the clamp (7).
7. Remove the air cleaner (8) from the air cleaner body (9).
8. Gently wash the air cleaner in clean, non-flammable (high flash point) solvent such as kerosene — not gasoline. After cleaning, gently squeeze out the remaining solvent. Avoid twisting or wringing the air cleaner. This can tear the foam.
9. Inspect for tears or cracks in the foam or seams of the air cleaner. Replace the air cleaner if it is damaged.
10. Allow the air cleaner to dry thoroughly before applying oil. A wet air cleaner will not fully absorb the oil.
11. Pour clean Pro Honda Foam Filter Oil or an equivalent (Canada: Honda Foam Filter Oil or an equivalent) over the entire surface of the air cleaner. Use both hands to evenly spread the oil into the air cleaner. Gently squeeze out any excess oil. (To keep your hands dry, place the air cleaner in a clean plastic bag before spreading the oil into the air cleaner.)

UNDER SEAT

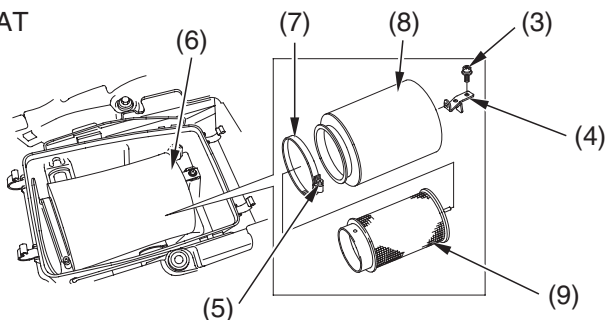

- (3) screw A
- (4) stay
- (5) screw B
- (6) air cleaner assembly

- (7) clamp
- (8) air cleaner
- (9) air cleaner body

Air Cleaner

12. Install the air cleaner on the air cleaner body.
13. Apply a thin coat of grease to the sealing surface of the air cleaner assembly.
14. Install the clamp.
15. Insert the air cleaner assembly into the air cleaner housing.
16. Fasten the screw B.
17. Install the stay and fasten the screw A.
18. Install the air cleaner housing cover and latch the retainer clips.

Throttle

Throttle Freeplay

Refer to *Safety Precautions* on page 77 .

RIGHT HANDLEBAR

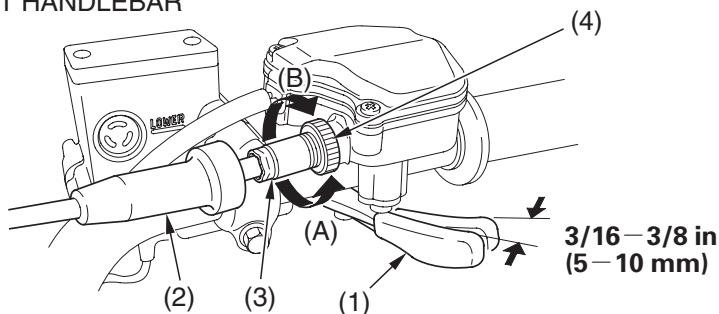

- | | |
|-----------------------------|-----------------------|
| (1) throttle lever | (4) lock nut |
| (2) rubber sleeve | (A) decrease freeplay |
| (3) throttle cable adjuster | (B) increase freeplay |

Inspection

Check freeplay at the throttle lever (1).

Freeplay:

$3/16 - 3/8$ in (5–10 mm)

Adjustment

1. Slide the rubber sleeve (2) back to expose the throttle cable adjuster (3).
2. Loosen the lock nut (4).
3. Turn the adjuster to obtain the correct freeplay.
4. Tighten the lock nut and reinstall the sleeve.
5. After adjustment, check for smooth operation of the throttle lever from fully closed to fully open in all steering positions.
6. Make sure the engine starts. If the engine does not start or engine stall, see your Honda dealer.

Throttle Inspection

Refer to *Safety Precautions* on page 77 .

1. Check that the throttle assembly is positioned properly and the securing bolts are tight.
2. Check for smooth operation of the throttle lever from fully open to fully closed in all steering positions. If there is a problem, see your Honda dealer.
3. Inspect the condition of the throttle cables from the throttle lever down to the carburetor. If the cable is kinked or chafed, have it replaced.
4. Check the cables for tension or stress in all steering positions.
5. Lubricate the cables with a commercially-available cable lubricant to prevent premature wear and corrosion.

Clutch System

Clutch Adjustment

Refer to *Safety Precautions* on page 77 .

LEFT HANDLEBAR

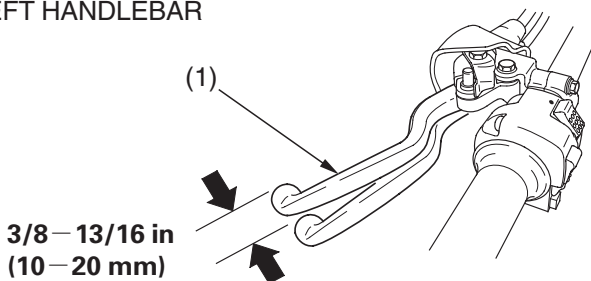

(1) clutch lever/parking brake lever

Clutch adjustment may be required if the ATV stalls when shifting into gear, if it tends to creep, or if the clutch slips, causing acceleration to lag behind engine speed.

Inspection

Check freeplay.

Freeplay:

3/8 – 13/16 in (10 – 20 mm)

If necessary, adjust to the specified range.

Improper freeplay adjustment can cause premature clutch wear.

Clutch System

Upper Adjustment

Minor adjustments are generally made with the upper clutch cable adjuster.

LEFT HANDLEBAR

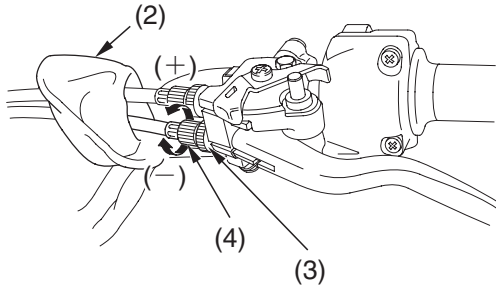

(2) dust cover

(3) upper lock nut

(4) upper clutch cable
adjuster

(+) increase freeplay

(-) decrease freeplay

1. Pull back the dust cover (2).
2. Loosen the upper lock nut (3).
3. Turn the upper clutch cable adjuster (4) to obtain the specified freeplay.
4. Tighten the lock nut and check the freeplay again.
5. Pull on the dust cover.

If proper adjustment cannot be obtained or the clutch does not work correctly, the cable or clutch friction discs may be worn. See your Honda dealer.

Clutch System

Lower Adjustment

The lower clutch cable adjuster is used if the upper clutch cable adjuster is threaded out near its limit—or the correct freeplay cannot be obtained.

LEFT SIDE

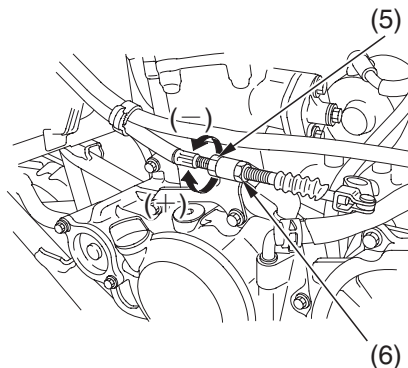

(5) lower adjusting nut

(6) lower lock nut

(+) increase freeplay

(-) decrease freeplay

1. Loosen the upper lock nut (3) and turn the upper clutch cable adjuster (4) all the way in (to provide maximum freeplay).
2. Tighten the upper lock nut and pull the dust cover (2) back to its normal position.
3. Hold the lower adjusting nut (5) and loosen the lower lock nut (6) at the lower end of the cable.
4. Turn the lower adjusting nut to obtain the specified freeplay.
5. Hold the lower adjusting nut and tighten the lower lock nut. Check the adjustment.

Clutch System

6. Start the engine, pull the clutch lever/parking brake lever in, and shift into gear. Make sure the engine does not stall and the ATV does not creep. Gradually release the clutch lever/parking brake lever and open the throttle. Your ATV should move smoothly and accelerate gradually.

Check the clutch lever/parking brake lever and clutch cable for loose connections or other damage. If the clutch cable is worn or kinked, have it replaced by your Honda dealer.

Other Inspections & Lubrication

- Check that the clutch lever/parking brake lever assembly is positioned properly and the securing bolts are tight.
- Check the clutch cable for kinks or signs of wear. If necessary, have it replaced.
- Lubricate the clutch cable with a commercially-available cable lubricant to prevent premature wear and corrosion.

Engine Idle Speed

The best way to assure proper carburetion is to see your Honda dealer for regularly scheduled servicing, including carburetor adjustment.

Remember, idle speed adjustment is not a “cure-all” for other problems in your engine’s fuel-delivery system. Adjusting the idle will not compensate for a fault elsewhere.

The engine must be at normal operating temperature for accurate idle speed adjustment.

For information about high altitude carburetor adjustment, see page 206 .

Idle Speed Adjustment

Refer to *Safety Precautions* on page 77 .

RIGHT SIDE

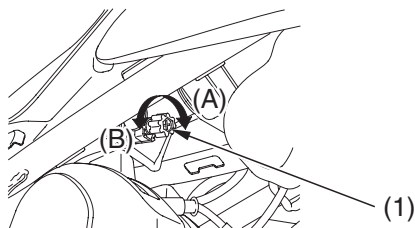

(1) throttle stop screw

(A) increase

(B) decrease

1. If the engine is cold, start it and warm it up with ten minutes of stop-and-go riding. Stop the engine.
2. Park your ATV on a firm, level surface.
3. Connect a tachometer to the engine.
4. Shift into neutral. Start the engine.
5. Adjust idle speed by turning the throttle stop screw (1).

Idle speed (in neutral):

$1,700 \pm 100$ rpm

Spark Plug

Spark Plug Recommendation

standard spark plug	IFR7L11 (NGK) or VK22PRZ11 (DENSO)
for extended high speed riding	IFR8H11 (NGK) or VK24PRZ11 (DENSO)

Use only the recommended type of spark plug in the recommended heat range.

NOTICE

Using spark plug with an improper heat range can cause engine damage.

This ATV uses spark plug that have an iridium coated center electrode. Be sure to observe the following when servicing the spark plug.

- Do not clean the spark plug. If an electrode is contaminated with accumulated objects or dirt, replace the spark plug with a new one.
- To check the spark plug gap, use only a “wire-type feeler gauge.” To prevent damaging the iridium coating of the center electrode, never use a “leaf-type feeler gauge.”
- Do not adjust the spark plug gap. If the gap is out of specification, replace the spark plug with a new one.

Spark Plug

Spark Plug Inspection & Replacement

Refer to *Safety Precautions* on page 77 .

1. Clean any dirt from around the spark plug base.
2. Disconnect the spark plug cap (1). Take care to avoid damaging the spark plug wire when disconnecting the cap.
3. Using a spark plug wrench provided in the tool kit, remove the spark plug.
4. Inspect the electrode and center porcelain for deposits, corrosion, or carbon fouling. If the corrosion or deposits are heavy, replace the plug.
5. Make sure that a 1.2 mm wire-type feeler gauge cannot be inserted between the spark plug gap (2). If the gauge fits in the gap, replace the plug with a new one.

RIGHT SIDE

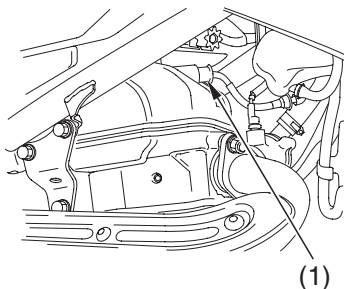

(1) spark plug cap

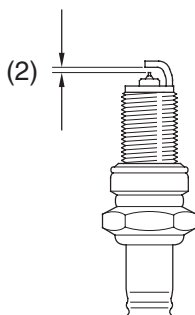

(2) spark plug gap

Spark Plug

6. With the plug washer attached, thread the spark plug in by hand to prevent cross-threading.
7. Tighten the spark plug:
 - If the old plug is good:
 - 1/8 turn after it seats.
 - If installing a new plug, tighten it twice to prevent loosening:
 - a) First, tighten the plug:
 - NGK: 3/4 turn after it seats.
 - DENSO: 1/2 turn after it seats.
 - b) Then loosen the plug.
 - c) Next, tighten the plug again:
 - 1/8 turn after it seats.

NOTICE

An improperly tightened spark plug can damage the engine. If a plug is too loose, a piston may be damaged. If a plug is too tight, the threads may be damaged.

8. Reinstall the spark plug cap. Take care to avoid pinching any cables or wires.

Valves

Valve Inspection

Refer to *Safety Precautions* on page 77 .

Valve clearance should be:

intake: 0.006 in (0.16 mm)

exhaust: 0.011 in (0.28 mm)

Excessive clearance will cause noise. Insufficient clearance will cause loss of power and possibly damage the valves.

For those who are mechanically proficient and have the proper tools, instructions on adjusting valve clearances are given in the official Honda Service Manual. All others should have valves adjusted by your Honda dealer.

Spark Arrester

Refer to *Safety Precautions* on page 77 .

The spark arrester must be serviced every 100 operating hours to maintain its efficiency.

Regular servicing prevents carbon build up (which can diminish engine performance) and also complies with USDA regulations for regular maintenance to assure proper function. The spark arrester prevents random sparks from the combustion process in your engine from reaching the environment.

1. Allow the engine and muffler to cool.
2. Remove the bolts (1), the muffler tail cover (2), the spark arrester (3), and the gasket (4) from the muffler (5).

REAR

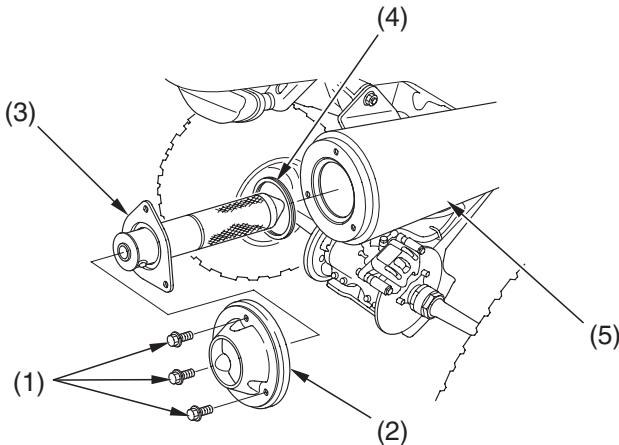

- (1) bolts
- (2) muffler tail cover
- (3) spark arrester

- (4) gasket
- (5) muffler

(cont'd)

Spark Arrester

3. Use a brush to remove carbon deposits from the spark arrester screen (6). Be careful to avoid damaging the spark arrester screen. The spark arrester must be free of breaks and holes. Replace, if necessary. Check the gasket. Replace, if necessary.

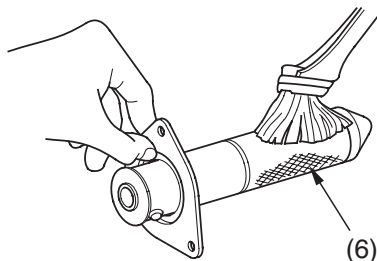

(6) spark arrester screen

4. Install the gasket to the muffler, the spark arrester, and the muffler tail cover and tighten the bolts securely.

Suspension

Your front and rear suspension systems use springs and hydraulic damping devices that suspend your weight and most of the weight of your ATV.

The oil damper systems hydraulically control the natural compression and rebound of the suspension springs so that traction and comfort are maintained as the wheels ride over road surfaces.

The way you ride your ATV and the type of ride you want to experience can also influence your suspension needs.

You may adjust the rebound and compression damping of the front and rear suspension systems.

Suspension

Suspension Adjustment

The suspension can be adjusted for rider weight and riding conditions by changing the rebound and compression damping.

The shock absorber assemblies include a damper unit that contains high pressure nitrogen gas. Do not attempt to disassemble, service, or dispose of the damper; see your Honda dealer. The instructions found in this owner's manual are limited to adjustments of the shock assemblies.

Suspension

Front Suspension Damping

Refer to *Safety Precautions* on page 77 .

Rebound Damping RIGHT FRONT

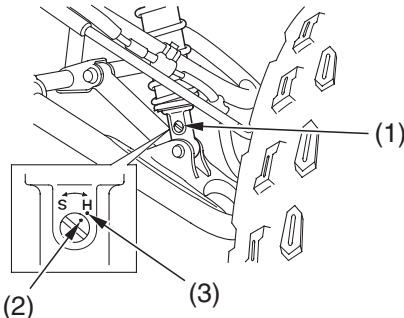

- (1) rebound damping adjuster (3) reference punch mark
(2) punch mark

To adjust to the standard position:

1. Turn the rebound damping adjuster (1) clockwise until it will no longer turn (lightly seats). This is the full hard setting.
2. Turn the adjuster counterclockwise approximately 1 turns so that the punch mark (2) on the adjuster aligns with the reference punch mark (3). This is the standard position.
3. Make sure that both shock absorbers are adjusted to the same position.

To Reduce Rebound Damping (SOFT):

For a light load and smooth road conditions, turn the adjuster counterclockwise toward SOFT (S).

To Increase Rebound Damping (HARD):

For a firmer ride and rough road conditions, turn the adjuster clockwise toward HARD (H).

Suspension

Compression Damping LEFT FRONT

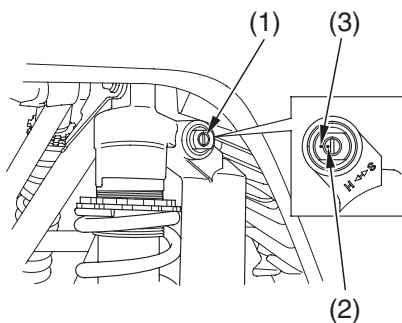

- (1) compression damping adjuster (3) reference punch mark
(2) punch mark

To adjust to the standard position:

1. Turn the compression damping adjuster (1) clockwise until it will no longer turn (lightly seats). This is the full hard setting.
2. Turn the adjuster counterclockwise approximately $1 \frac{7}{8}$ turns so that the punch mark (2) on the adjuster aligns with the reference punch mark (3). This is the standard position.
3. Make sure that both shock absorbers are adjusted to the same position.

To Reduce Compression Damping (SOFT):

For a light load and smooth road conditions, turn the adjuster counterclockwise toward SOFT (S).

To Increase Compression Damping (HARD):

For a firmer ride and rough road conditions, turn the adjuster clockwise toward HARD (H).

Suspension

Rear Suspension Damping

Refer to *Safety Precautions* on page 77 .

Rebound Damping

LEFT REAR

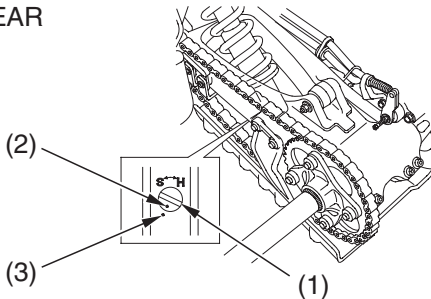

- (1) rebound damping adjuster (3) reference punch mark
(2) punch mark

To adjust to the standard position:

1. Turn the rebound damping adjuster (1) clockwise until it will no longer turn (lightly seats). This is the full hard setting.
2. Turn the adjuster counterclockwise approximately $1 \frac{6}{8}$ turns so that the punch mark (2) on the adjuster aligns with the reference punch mark (3). This is the standard position.

To Reduce Rebound Damping (SOFT):

For a light load and smooth road conditions, turn the adjuster counterclockwise toward SOFT (S).

To Increase Rebound Damping (HARD):

For a firmer ride and rough road conditions, turn the adjuster clockwise toward HARD (H).

Suspension

Compression Damping

LEFT SIDE

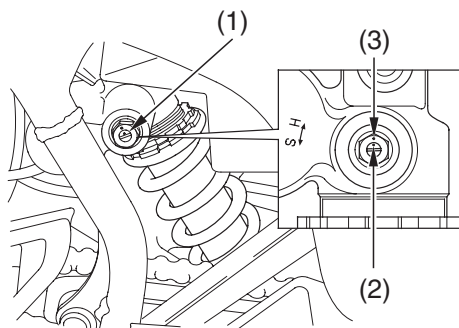

- (1) compression damping adjuster (3) reference punch mark
(2) punch mark

To adjust to the standard position:

1. Turn the compression damping adjuster (1) clockwise until it will no longer turn (lightly seats). This is the full hard setting.
2. Turn the adjuster counterclockwise 26 clicks so that the punch mark (2) on the adjuster aligns with the reference punch mark (3). This is the standard position.

To Reduce Compression Damping (SOFT):

For a light load and smooth road conditions, turn the adjuster counterclockwise toward SOFT (S).

To Increase Compression Damping (HARD):

For a firmer ride and rough road conditions, turn the adjuster clockwise toward HARD (H).

Brakes

The hydraulic disc braking systems on your ATV dissipate the heat generated by the friction of the brake pads on the brake discs as the wheels are slowed.

As the brake pads wear, the brake fluid level will drop. A leak in the system will also cause the level to drop.

There are no adjustments to perform, but fluid level and pad wear must be inspected periodically. The system must be inspected frequently to ensure there are no fluid leaks.

If the brake lever or brake pedal freeplay does not feel within the normal range while riding, check the brake pads for wear (page 137). Worn pads should be replaced. If the pads are not worn beyond the recommended limit, there is probably air in the brake system. See your Honda dealer to have the air bled from the system.

Brake Fluid Recommendation

brake fluid	Honda DOT 4 Brake Fluid
-------------	-------------------------

The recommended brake fluid is Honda DOT 4 Brake Fluid, or any brake fluid of equal quality and performance. Use fresh brake fluid from a sealed container. Be sure to read the label before opening the sealed container. An opened container may be contaminated or may have absorbed moisture from the air.

Brakes

Fluid Level Inspection

Refer to *Safety Precautions* on page 77 .

If your inspection indicates a low fluid level, have your Honda dealer add the recommended fluid.

Do not add or replace brake fluid, except in an emergency. If you do add fluid, have your Honda dealer check the system as soon as possible.

NOTICE

Brake fluid can damage plastic and painted surfaces. Handle with care.

Wipe up spills immediately. Avoid contact with skin or eyes. In case of contact, wash thoroughly and call a doctor immediately if it contacts your eyes.

Front Brake Fluid Level

RIGHT HANDLEBAR

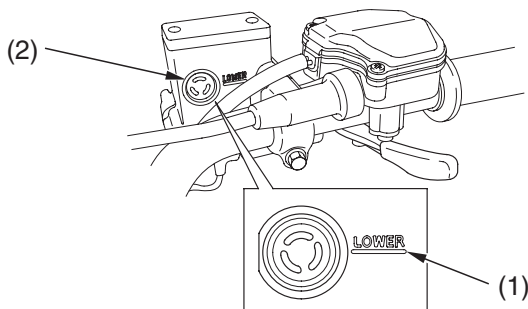

(1) LOWER level mark

(2) inspection window

Brakes

With the ATV in an upright position, check the fluid level. It should be above the LOWER level mark (1). If the level is at or below the LOWER level mark, check the brake pads for wear (page 137).

Worn brake pads should be replaced. If the pads are not worn, have your brake system inspected for leaks.

Rear Brake Fluid Level

RIGHT SIDE

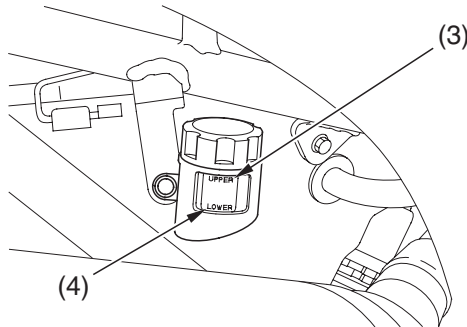

(3) UPPER level mark

(4) LOWER level mark

With the ATV in an upright position, check the fluid level. It should be between the UPPER (3) and LOWER (4) level mark. If the level is at or below the LOWER level mark, check the brake pads for wear (page 137).

Worn brake pads should be replaced. If the pads are not worn, have your brake system inspected for leaks.

Brakes

Other Inspections

- Make sure there are no fluid leaks.
- Check for deterioration or cracks in the hoses and fittings. If the hoses are worn or cracked, have them replaced by your Honda dealer.

Brake Pad Wear

Refer to *Safety Precautions* on page 77.

Brake pad wear will depend upon the severity of usage and riding conditions. The pads will wear faster in wet or muddy conditions. Inspect the pads visually during all regular service intervals to determine the pad wear.

RIGHT FRONT
(Left side similar)

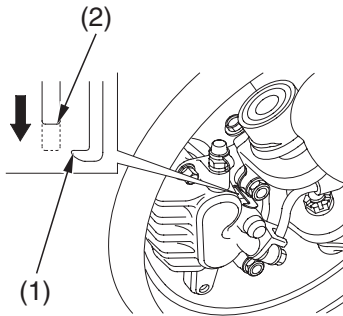

(1) wear indicator

REAR

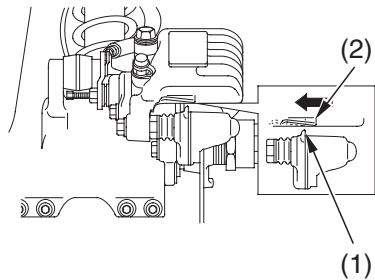

(2) edge of reference mark

Check the wear indicator (1). If the wear indicator aligns with the edge of the reference mark (2), both pads must be replaced, see your Honda dealer for this replacement.

Always inspect each pad of the right and left front brake calipers.

Brakes

Front Brake Lever Adjuster

Refer to *Safety Precautions* on page 77.

The distance between the tip of the front brake lever and the grip can be adjusted.

RIGHT HANDLEBAR

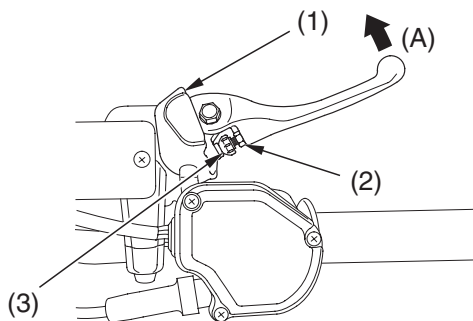

(1) brake lever cover

(3) adjust bolt

(2) lock nut

1. Pull back the brake lever cover (1).
2. Loosen the lock nut (2), push the front brake lever forward (A), and turn the adjust bolt (3).
3. Apply the brake, release it, then spin the wheel and check that it rotates freely. Repeat this procedure several times.
4. Fasten the lock nut.

Right Side Mudguard Removal

Refer to *Safety Precautions* on page 77 .

The right side mudguard must be removed to adjust the rear brakelight switch.

RIGHT SIDE

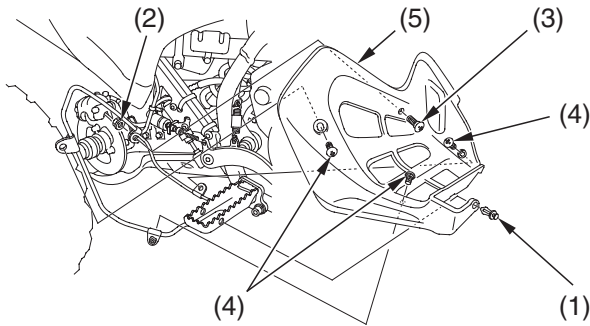

(1) clip
(2) nut

(3) screw A
(4) screws B

(5) right side mudguard

Removal

1. Remove the clip (1), the nut (2), and screw A (3).
2. Remove the screws B (4) and right side mudguard (5).

Installation

Install the right side mudguard in the reverse order of removal.

Brakes

Brakelight Switch Adjustment

Refer to *Safety Precautions* on page 77 .

Rear Brake Only:

Check the operation of the rear brakelight switch (1) at the right side behind the engine from time to time. The brakelight should turn on at 0.6 in (15 mm) of pedal stroke. Remove the right side mudguard (see page 139). Adjustment is done by turning the adjusting nut (2). Turn the nut in direction (A) if the switch operates too late and in direction (B) if the switch operates too soon.

RIGHT SIDE

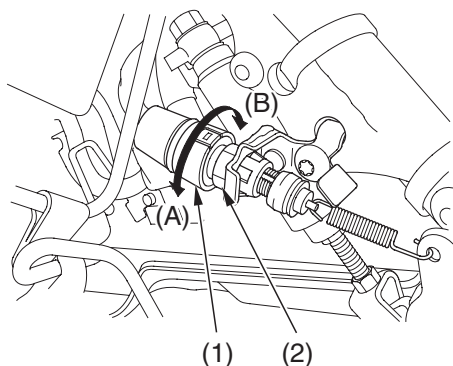

(1) brakelight switch

(2) adjusting nut

Parking Brake Adjustment

Refer to *Safety Precautions* on page 77.

Parking brake adjustment may be required if the parking brake does not hold properly.

LEFT HANDLEBAR

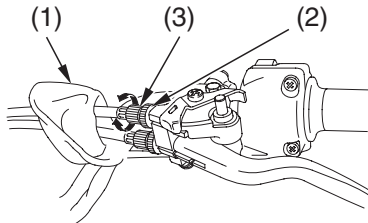

- (1) dust cover
- (2) lock nut
- (3) adjuster

REAR

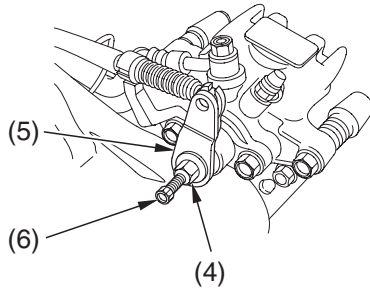

- (4) lock nut
- (5) parking brake arm
- (6) adjusting bolt

Adjustment

1. Temporarily adjust the clutch lever/parking brake lever freeplay to more than 1 3/16 in (30 mm) (page 116).
2. Pull back the dust cover (1).
3. Loosen the lock nut (2) on the parking brake cable, and screw in the adjuster (3) completely.
4. Loosen the lock nut (4) on the parking brake arm (5) and turn the adjusting bolt (6) clockwise until you feel resistance.
5. Then turn the adjusting bolt (6) 1/8 counterclockwise, and tighten the lock nut (4).

(cont'd)

Brakes

6. Push down the parking brake pin (7) and then squeeze the clutch lever/parking brake lever (8) until firm resistance is felt. Measure the distance the clutch lever/parking brake lever has moved; the distance should be:
1 – 1 3/16 in (25 – 30 mm)
7. If necessary, adjust the clutch lever/parking brake lever freeplay (page 116).

LEFT HANDLEBAR

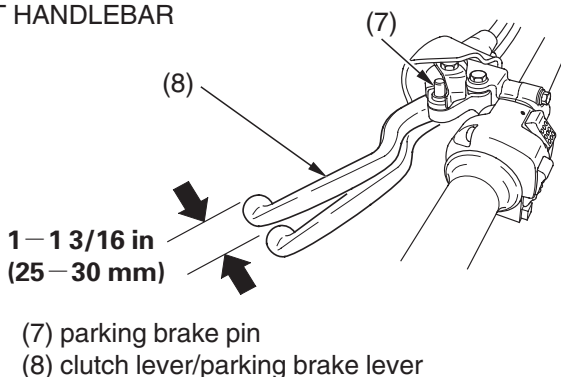

Check the clutch lever/parking brake lever and parking brake cable for loose connections or other damages. If the parking brake cable is worn or kinked, have it replaced by your Honda dealer.

Other Inspections & Lubrication

- Check that the clutch lever/parking brake lever assembly is positioned properly and the securing bolts are tight.
- Check the parking brake cable for kinks or signs of wear. If necessary, have it replaced.
- Lubricate the parking brake cable with a commercially-available cable lubricant to prevent premature wear and corrosion.

To safely operate your ATV, your tires must be the proper type and size, in good condition with adequate tread, and correctly inflated.

⚠ WARNING

Using tires that are excessively worn or improperly inflated can cause a crash in which you can be seriously hurt or killed.

Follow all instructions in this owner's manual regarding tire inflation and maintenance.

This ATV is equipped with low pressure tubeless tires. Although the tires are designed specifically for off-road use, they are not immune to punctures. Always select your riding area with care.

The following pages give detailed information on how and when to check your air pressure, how to inspect your tires for wear and damage, and our recommendations for tire repair and replacement.

Tires

Air Pressure

Refer to *Safety Precautions* on page 77 .

Properly inflated tires provide the best combination of handling, tread life, and riding comfort. Generally, underinflated tires wear unevenly, adversely affect handling, and are more likely to fail from being overheated. Overinflated tires make your ATV ride harshly, are more prone to damage from surface hazards, and wear unevenly.

Make sure the air valve caps are secure. If necessary, install new caps.

Tires

Always check air pressure when your tires are “cold.” If you check air pressure when your tires are “warm” — even if your ATV has only been ridden for a few miles — the readings will be higher. If you let air out of warm tires to match the recommended cold tire pressures, the tires will be underinflated. Be sure to check tire pressure at the riding site, since changes in altitude can affect air pressure.

The recommended “cold” tire pressures are:

	FRONT	REAR
RECOMMENDED PRESSURE	4.0 psi (27.5 kPa , 0.275 kgf/cm ²)	4.7 psi (32.5 kPa , 0.325 kgf/cm ²)

Tires

A manually operated tire pump should be used rather than the high pressure system found in service stations. This will minimize the possibility of tire damage from overinflation. If you use a high pressure system at a service station, add air in small amounts and check the pressure increase frequently to prevent possible tire damage from overinflation.

WARNING

Operating this ATV with improper tires, or with uneven tire pressure may cause loss of control, and you could be seriously injured or killed.

- Always use the size and type tires specified in this owner's manual for this vehicle.
- Always maintain proper tire pressure as described in this owner's manual.

Inspection

Refer to *Safety Precautions* on page 77 .

Whenever you check the tire pressures, you should also look for:

- Bumps or bulges in the side of the tire or the tread. Replace any tire that has a bump or bulge.
- Cuts, slits, or cracks in the tires. Replace the tire if you can see fabric or cord.
- Nails or other foreign objects embedded in the side of the tire or tread.
- Excessive tread wear.

Tires

Also, if you hit a pothole or other hard object while riding, stop as soon as you safely can and carefully inspect the tires for damage.

Tread Wear

FRONT

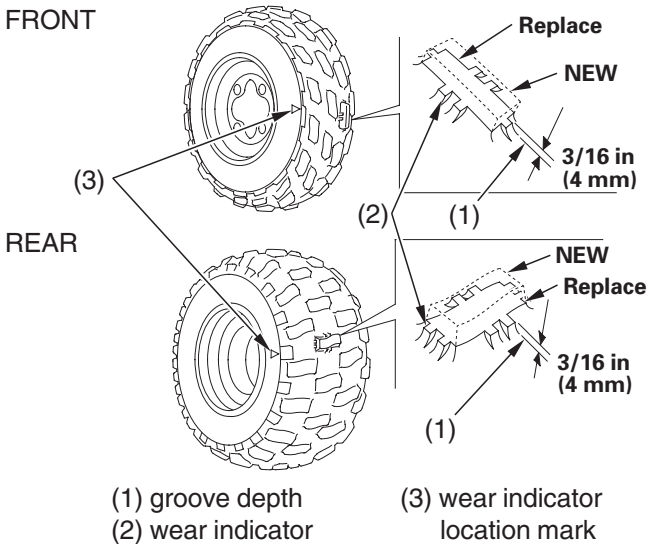

(1) groove depth
(2) wear indicator

(3) wear indicator
location mark

To check the condition of a tire tread, measure the groove depth (1) in the center of the tire, or check the wear indicator (2).

For best performance, you should replace a tire before the tread depth at the center reaches the following limits:

front	3/16 in (4 mm)
rear	3/16 in (4 mm)

Tires

Tire Repair

Refer to *Safety Precautions* on page 77 .

A tire that is repaired, either temporarily or permanently, will have lower speed and performance limits than a new or undamaged tire.

A temporary repair can sometimes be made in an emergency situation. However, since a temporary repair may not hold, you must ride very slowly and have the tire replaced or permanently repaired as soon as possible. (For more information on temporary repairs, see *If You Have a Flat Tire*, page 186 .)

A permanent repair, such as an internal plug patch, can be made if a tire has only a small puncture in the tread area. However you may not be able to safely carry as much weight. If you choose to have a tire repaired, be sure the repair work is performed by a professional.

If you have a tire professionally repaired at a non-Honda facility, we recommend that you have the work checked by your Honda dealer.

Tire Replacement

Refer to *Safety Precautions* on page 77 .

The tires that came on your ATV were designed to match the performance capabilities of your ATV and provide the best combination of handling, braking, and comfort.

It is best to replace all four tires, however if that is not possible, you must replace the tires in pairs (front or rear) with tires of the same size and type as the originals. Never replace just one tire.

WARNING

Installing improper tires on your ATV can affect handling and stability. This can cause a crash in which you can be seriously hurt or killed.

Always use the size and type of tires recommended in this owner's manual.

The recommended tires for your ATV are:

front	AT21 × 7R10 ★★ DUNLOP KT331H
rear	AT20 × 10R9 ★★ DUNLOP KT355H

When you replace a tire, remember:

Have the tire replaced by your Honda dealer if possible.

If you have a tire professionally replaced at a non-Honda facility, we recommend that you have the work checked by your Honda dealer.

Engine Guard & Skid Plates

Refer to *Safety Precautions* on page 77.

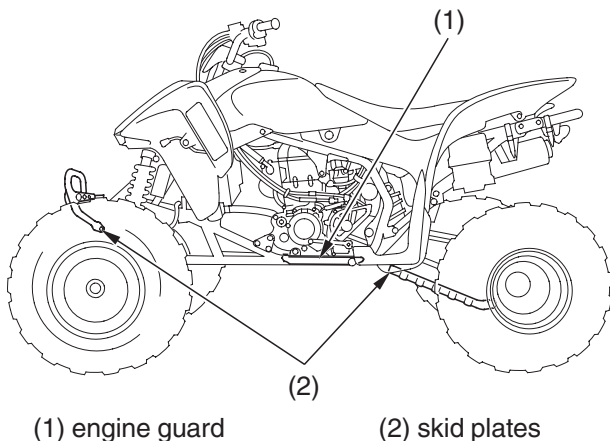

The engine guard (1) protects the engine crankcase.

The skid plates (2) protect the frame/lower arm, the drive components and the rear brake. Check the guard and plates for cracks, damage or looseness at intervals shown in the Maintenance Schedule.

Have the engine guard and skid plates replaced if they are cracked or damaged. If the guard and plate bolts are loose, tighten them securely.

Drive Chain

An endless (riveted master link) chain connects the front and rear wheel sprockets. The O-ring chain uses rubber rings between the side plates of the pin and roller links to seal in the manufacturer-installed lubricating grease and keep out moisture and dirt.

The service life of the chain depends on proper lubrication and adjustment. Poor maintenance can cause premature wear or damage to the drive chain or sprockets.

The drive chain should be checked, adjusted, and lubricated as part of the pre-ride inspection (page 33).

Under severe usage, or when the ATV is ridden in unusually dusty or muddy areas, more frequent maintenance will be necessary.

Before servicing your drive chain, turn the engine OFF and check that your transmission is in neutral.

It is not necessary to remove or replace the drive chain to perform the recommended service in the Maintenance Schedule.

Inspection

Refer to *Safety Precautions* on page 77 .

1. Chain slack should be checked by measuring the amount of chain slack midway between the sprockets. The amount of slack should be:
1 – 1 3/8 in (25 – 35 mm)

(cont'd)

Drive Chain

LEFT SIDE

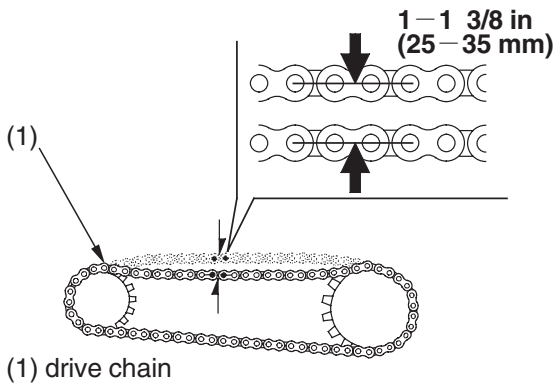

2. Check drive chain slack at several points along the chain. The slack should remain constant. If it isn't, some links may be kinked and binding. Lubricating the chain will often eliminate binding and kinking.

NOTICE

Excessive chain slack may allow the drive chain to damage the engine cases.

3. Inspect the drive chain for:
 - damaged rollers
 - loose pins
 - dry or rusted links
 - kinked or binding links
 - excessive wear
 - damaged or missing O-rings

Replace the drive chain (page 157) if it has damaged rollers, loose pins, or kinks that cannot be freed. Lubricate the drive chain (page 156) if it appears dry or shows signs of rust. Lubricate any kinked or binding links and work them free. Adjust chain slack if needed.

Drive Chain

4. Check the drive chain slider (1) at the intervals specified in the Maintenance Schedule.

The chain slider must be replaced if it is worn to the wear limit line (2). For replacement, see your Honda dealer.

LEFT SIDE

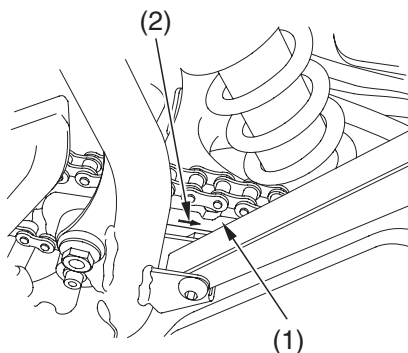

(1) drive chain slider

(2) wear limit line

5. With the upper or lower section of drive chain tight between the sprockets measure the distance between a span of 21 pins from pin center to pin center. If the distance exceeds the service limit, the chain is worn out and should be replaced.

Service limit:

12.56 in (319.1 mm)

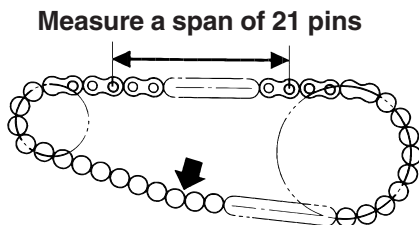

(cont'd)

Drive Chain

6. Check the chain roller (1) for wear and have it replaced if necessary. The chain roller must be replaced if it is worn to 1/16 in (1.5 mm). For replacement, see your Honda dealer.

LEFT SIDE

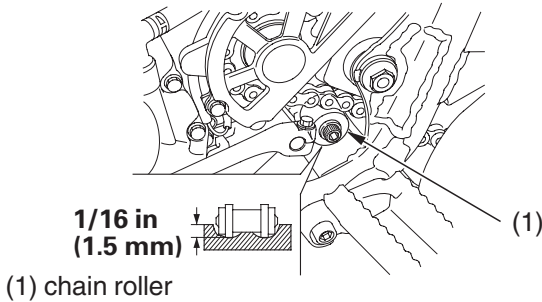

7. Inspect the front and rear sprocket teeth for excessive wear or damage. If necessary, have your Honda dealer replace a worn sprocket.

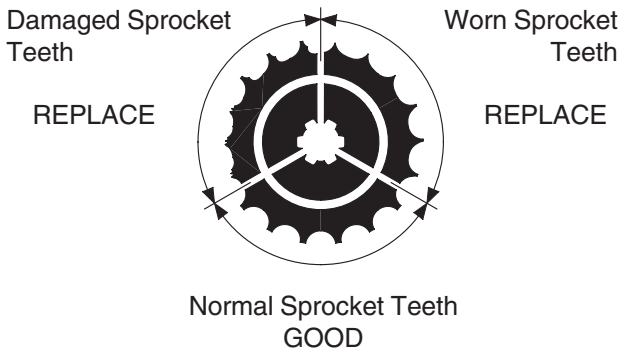

NOTICE

Use of a new chain with worn sprockets will cause rapid chain wear.

Drive Chain

Adjustment

Refer to *Safety Precautions* on page 77.

1. To adjust slack, use an Allen wrench (1) to loosen the rear axle holder fixing bolts (2).
2. Turn the adjuster (3) to decrease (A) or increase (B) chain slack.
3. Retighten the rear axle holder fixing bolts.

Rear axle holder fixing bolts torque:

15 lbf·ft (21 N·m , 2.1 kgf·m)

If a torque wrench is not used for installation, see your Honda dealer as soon as possible to verify proper assembly.

REAR

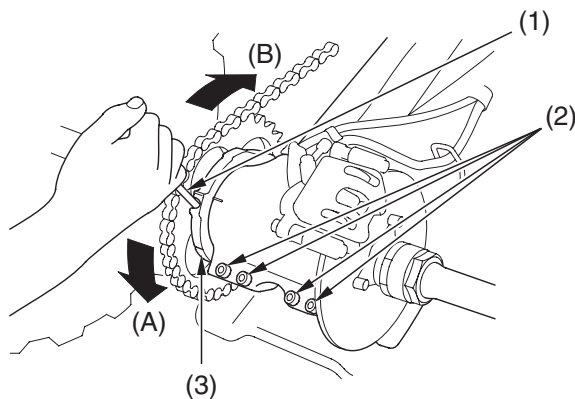

(1) Allen wrench
(2) fixing bolts

(3) adjuster

Drive Chain

Lubrication

Refer to *Safety Precautions* on page 77 .

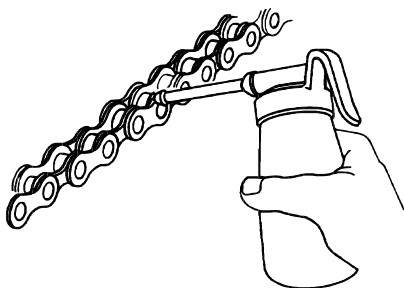

Lubricate every 30 days of riding or sooner if chain appears dry.

Lubricate only with SAE 80 or 90 gear oil. Commercial chain lubricants may contain solvents which could damage the rubber O-rings.

Drive Chain

Removal, Cleaning & Replacement

Refer to *Safety Precautions* on page 77.

Your ATV has an endless (riveted master link) type chain. It should only be removed or replaced by your Honda dealer.

The O-rings can be damaged by steam cleaning, high pressure washers, and certain solvents.

1. Clean the side surfaces of the chain with a dry cloth. Use a high flashpoint solvent such as kerosene — not gasoline.
Do not brush the rubber O-rings.
Brushing will damage them. Use of a solvent may also damage the O-rings.
2. Inspect the drive chain for possible wear or damage.

Replace the drive chain if it has damaged rollers, loose fitting links, damaged O-rings, or otherwise appears unserviceable.

Replacement Chain:

DID520V or RK520 SMOZ10S

Battery (TRX450ER only)

Your ATV has a maintenance-free type battery. You do not have to check the battery electrolyte level or add distilled water as you would with a conventional-type battery.

NOTICE

Your battery is a maintenance-free type and can be permanently damaged if the cap strip is removed.

Electrical accessories use current from the battery — even when the ignition is OFF. Limited operation also allows the battery to discharge. If you have electrical accessories on your ATV — or do not ride frequently — we recommend that you charge the battery frequently (see *Battery Charging*, page 162).

If you do not expect to ride your ATV for at least two weeks, we recommend you remove the battery — or at least disconnect the battery cables (negative cable first).

If you plan to store your ATV, see *Battery Storage*, page 159 .

If your battery seems weak and/or is leaking electrolyte (causing slow starting or other electrical problems), see your Honda dealer.

WARNING: Battery posts, terminals and related accessories contain lead and lead compounds. **Wash your hands after handling.**

Battery (TRX450ER only)

Battery Storage

Refer to *Safety Precautions* on page 77 .

If you plan to store your ATV, we recommend you remove the battery and store it where it can be charged at least every 30 days to maintain its service life.

If you do not remove the battery, we recommend disconnecting the battery cables (negative cable first).

You will get the best storage results from removing the battery and slow (trickle) charging it every 30 days (see *Battery Charging*, page 162).

Before you remove the battery, be sure to read all the information that follows, as well as the information on the battery label.

WARNING

The battery gives off explosive hydrogen gas during normal operation.

A spark or flame can cause the battery to explode with enough force to kill or seriously hurt you.

Wear protective clothing and a face shield, or have a skilled mechanic do the battery maintenance.

Battery (TRX450ER only)

The battery is located in a compartment under the left rear fender.

LEFT SIDE

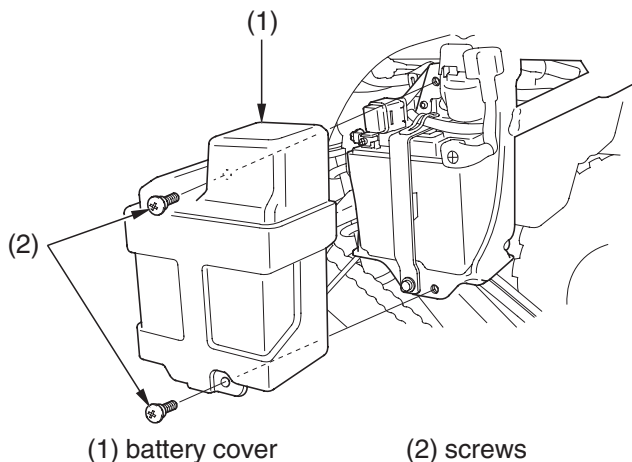

Removal

1. Make sure the ignition switch is OFF (\circ).
2. Remove the battery cover (1) by removing the screws (2).

Battery (TRX450ER only)

LEFT SIDE

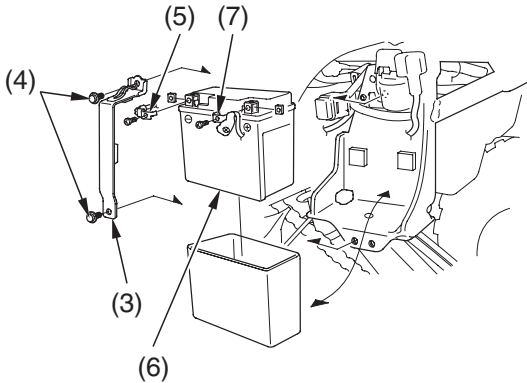

(3) battery holder

(4) mount bolts

(5) negative (−) terminal lead

(6) battery

(7) positive (+) terminal lead

3. Remove the battery holder (3) by removing the mount bolts (4).
4. Disconnect the negative (−) terminal lead (5) from the battery (6) first, then disconnect the positive (+) terminal lead (7).
5. Remove the battery.
6. Charge the battery (see following section), unless you have been riding regularly.
7. Store your battery in an easy-to-reach location off the floor, in an area protected from freezing temperature and direct sunlight.
8. Clean the battery box after removing the battery for storage. Dry the battery box and, if paint is missing, re-paint the area.
9. Slow charge the battery (see following section) once every 30 days.

Installation

1. Reinstall in the reverse order of removal.
Be sure to connect the positive (+) terminal first, then the negative (−) terminal.
2. Check all bolts and other fasteners are secure.

Battery (TRX450ER only)

Battery Charging

Refer to *Safety Precautions* on page 77 .

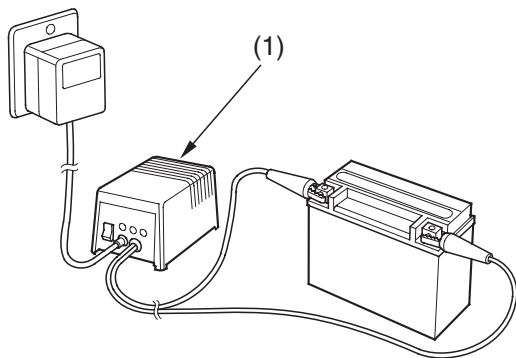

(1) “trickle” charger

Be sure to read the information that came with your battery charger and follow the instructions on the battery. Improper charging may damage the battery.

We recommend using a “trickle” charger (1) for home charging. These units can be left connected for long periods without risking damage to the battery. However, do not intentionally leave the charger connected longer than the time period recommended in the charger’s instructions.

Avoid using an automotive-type battery charger. An automotive charger can overheat an ATV battery and cause premature damage.

Appearance Care

Frequent cleaning and polishing will keep your Honda looking newer longer.

Frequent cleaning also identifies you as an owner who values his ATV. A clean ATV is also easier to inspect and service.

General Recommendations

Refer to *Safety Precautions* on page 77 .

- To clean your ATV, you may use:
 - water
 - a mild, neutral detergent and water
 - a mild spray and wipe cleaner/polisher
 - a mild spray and rinse cleaner/degreaser and water
- Avoid products that contain harsh detergents or chemical solvents that could damage the metal, paint, and plastic on your ATV.
- If your ATV is still warm from recent operation, give the engine and exhaust system time to cool off.
- Park in a shady area. Washing your ATV in bright sunlight may cause the finish to fade because water droplets intensify the sun's brightness.
- Spotting is also more likely because surface water can dry before you have time to wipe it off.
- Clean your ATV regularly to protect surface finishes.
- We recommend the use of a garden hose to wash your ATV. High pressure washers (like those at coin-operated car washers) can damage certain parts of your ATV.

NOTICE

High pressure water (or air) can damage certain parts of your ATV.

- After cleaning, inspect for damage, wear, and leaks (fuel, oil, coolant and brake fluid).

Appearance Care

Washing Your ATV with a Mild Detergent

Refer to *Safety Precautions* on page 77 .

1. Rinse your ATV thoroughly with cool water to remove loose dirt.
 2. Fill a bucket with cool water. Mix in a mild, neutral detergent, such as dish washing liquid or a product made especially for washing motorcycles or automobiles.
 3. Wash your ATV with a sponge or soft towel. As you wash, check for heavy grime. If necessary, use a mild cleaner/degreaser to remove the grime.
 4. After washing, rinse your ATV thoroughly with plenty of clean water to remove any residue. Detergent residue can corrode alloy parts.
 5. Dry your ATV with a chamois or a soft towel. Leaving water on the surface to air dry can cause dulling and water spots. As you dry, inspect for chips and scratches.
 6. Start the engine and let it idle for several minutes. The engine heat will help dry moist areas.
 7. As a precaution, ride your ATV at a slow speed and apply the brakes several times. This will help dry the brakes and restore normal braking performance.
- If the inside of the headlight lens appears clouded immediately after washing, it should clear after a few minutes of riding.

Appearance Care

Spray Cleaning Your ATV

Refer to *Safety Precautions* on page 77 .

Avoid using spray cleaner products on the tires or suspension components.

Suggestions for using spray cleaner(s) follow:

ATV condition	Recommended Cleaning
Dust and fingerprint smudges.	Apply a spray cleaner/polish and wipe paint, chrome, glass, and clear plastic.
Light road grimes.	Spray any difficult-to-reach or very dirty areas with a spray cleaner/degreaser. Rinse and dry. Apply a spray cleaner/polish and wipe with a non-abrasive cloth.
Heavy grime. Oil leaks. Brake dust.	Use a spray cleaner/degreaser. If necessary, rub with a sponge. Rinse and dry. Apply a spray cleaner/polish and wipe with a non-abrasive cloth.
Dull, corroded chrome or aluminum.	Apply a high quality chrome/aluminum polish and wipe with a non-abrasive cloth.

Appearance Care

Aluminum Wheel Maintenance

Refer to *Safety Precautions* on page 77 .

Aluminum may corrode from contact with dirt, mud, or road salt. Clean the wheels after riding through any of these substances. Use a wet sponge and mild detergent. Avoid stiff brushes, steel wool, or cleaners containing abrasives or chemical compounds.

After washing, rinse with plenty of water and dry with a clean cloth. Then apply a mild, commercially-available spray cleaner/polish or wax.

For stained or dull-looking wheels, use a quality chrome/aluminum polish to restore the finish.

Appearance Care

Finishing Touches

Refer to *Safety Precautions* on page 77 .

After washing your ATV, consider using a commercially-available spray cleaner/polish or quality liquid or paste wax to finish the job. Use only a non-abrasive polish or wax made specifically for motorcycles or automobiles. Apply the polish or wax according to the instructions on the container.

If a surface on your ATV is chipped or scratched, your Honda dealer has touch-up paint to match your ATV's color. Be sure to use your ATV's color code (page 199) when you buy touch-up paint.

If the frame has a chip that exposes the metal, first apply primer (to prevent corrosion) and then apply the touch-up paint. Several thin layers of touch-up paint are better than one thick coat.

Here's helpful advice on how to prepare for an off-road adventure, how to transport and store your Honda, and how to be an environmentally responsible ATV owner.

Preparing for a Ride	170
What to Take to the Riding Area	170
What to Take on the Trail	171
Transporting Your Honda	172
Storing Your Honda	174
Preparation for Storage	175
Removal from Storage	177
You & the Environment	178

Preparing for a Ride

A safe and enjoyable ride begins with good planning and preparation. Always ride with at least one other person in case you have trouble, and let someone know where you're going and when you expect to return.

Before riding in an unfamiliar area, find out in advance if you need special permits, get maps so you can study the terrain, and talk to other riders who know the area. The Forest Service and the Bureau of Land Management (USA only), the Ministry of Natural Resources (Canada only), riding clubs, and off-road magazines are good sources of information.

What to Take to the Riding Area

Along with your ATV and riding gear, you should take along some tools and supplies in case you have a problem. For some of the difficulties you might encounter, see *Taking Care of the Unexpected*, which begins on page 179.

We recommend that you always take water, food, a first aid kit, and your owner's manual. Other items you should consider loading on your truck or trailer include:

- a tool kit
- tire repair supplies and tools, and tires
- extra parts, control levers, cables, and spark plugs
- wire, duct tape, and rope
- extra gasoline

For safety, all refueling should be done at a gas station on the way to the riding area or at your base camp.

Preparing for a Ride

What to Take on the Trail

What you take with you during a ride depends on the kind of terrain, how long you expect to ride, how far you might go from your base camp or help, and how experienced you or your companions are in making repairs.

If you decide to take some tools, spare parts, or other supplies on the trail, be sure you can carry them safely and know how to use them. Also, be sure to follow the loading guidelines and weight limit (page 37).

Transporting Your Honda

Do not tow your ATV behind a car or other vehicle.

When you transport your ATV, we recommend that you carry the vehicle in its normal operating position (on all four wheels). Do not incline the vehicle upright on its rear end. This can damage the vehicle, and leaking gasoline could be a hazard.

Follow these procedures:

1. Set the parking brake and place the transmission in gear.
2. Turn the fuel valve OFF.

Transporting Your Honda

- Secure the vehicle with “tie-down straps” in the areas shown.
 - Suitable “tie-down straps” are available from your Honda dealer.
 - Ordinary rope is not recommended because it can stretch under load.
 - Using “tie-down straps” in any other areas can damage your ATV.
- Rock the vehicle back and forth to make sure the “tie-down straps” are tight and the vehicle is secure.

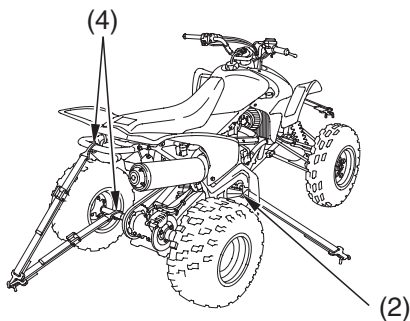
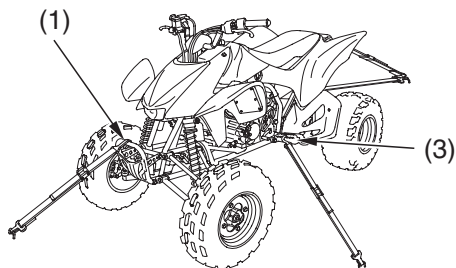

(1) front carry pipe
(2) right footpeg

(3) left footpeg
(4) rear carry pipe or rear axle shaft

Storing Your Honda

If you won't be riding for an extended period, such as during the winter, thoroughly inspect your ATV and correct any problem before storing it. That way, needed repairs won't be forgotten and it will be easier to get your ATV running again.

For more information about storage, refer to the *Honda Motorcycle Winter Storage Guide*, available from your Honda dealer (USA only).

We suggest you perform the following procedures to keep your ATV in top condition. These storage procedures will reduce the deterioration that can occur during storage.

Storing Your Honda

Preparation for Storage

Refer to *Safety Precautions* on page 77.

This procedure requires a means for draining and disposing of drained fuel (page 178).

1. Change the engine oil and filter (page 96).
2. Change the transmission oil (page 102).
3. Make sure the cooling system is filled with a 50/50% antifreeze solution (page 105).
4. Fill the fuel tank. Make sure the fuel fill cap is properly installed.
5. Check that the fuel valve is OFF.
6. Drain the carburetor into an approved gasoline container and dispose of it in an approved manner (page 178).

If storage will last longer than one month, carburetor draining is important to assure proper performance after storage.

WARNING

Gasoline is highly flammable and explosive. You can be burned or seriously injured when handling fuel.

- Stop the engine and keep heat, sparks and flame away.
- Handle fuel only outdoors.
- Wipe up spills immediately.

7. To prevent rusting in the cylinder, perform the following:
 - Remove the spark plug cap from the spark plug.
 - Remove the spark plug.Do not connect the spark plug to the spark plug cap.

(cont'd)

Storing Your Honda

- Pour a tablespoon (15 – 20 cc) of clean engine oil into the cylinder and cover the spark plug hole with a piece of cloth.
(TRX450ER)
 - With the engine stop switch in the OFF (⌘) position, press the start button several times to crank the engine and distribute the oil.
(TRX450R)
 - With the engine stop switch in the OFF (⌘) position, depress the kickstarter several times to crank the engine and distribute the oil.
 - Reinstall the spark plug and spark plug cap.
8. (TRX450ER only)
Remove the battery and charge it fully. Store it in an area protected from freezing temperatures and direct sunlight. Slow charge the battery (page 162) once a month.

WARNING

The battery gives off explosive hydrogen gas during normal operation.

A spark or flame can cause the battery to explode with enough force to kill or seriously hurt you.

Wear protective clothing and a face shield, or have a skilled mechanic do the battery maintenance.

9. Wash and dry your ATV. Wax all painted surfaces.
10. Lubricate the drive chain (page 156).

Storing Your Honda

11. Inflate the tires to their recommended pressures (page 144).
12. Store your ATV in an unheated area, free of dampness, away from sunlight, with a minimum of daily temperature variation.
13. Place your ATV on blocks to lift all tires off the floor.
14. Cover your ATV with a porous material. Avoid using plastic or similar non-breathing, coated materials that restrict air flow and allow heat and moisture to accumulate.

Removal from Storage

Refer to *Safety Precautions* on page 77 .

1. Uncover and clean your ATV.
2. If your ATV has been stored for more than four months — change the engine oil (page 96) and transmission oil (page102).
Add coolant to the reserve tank as required to bring the coolant level to the UPPER level mark.
3. If your ATV has been stored for more than two months — ask your Honda dealer to drain and replace the fuel.
4. Lubricate the drive chain (page 156).
5. (TRX450ER only)
Charge the battery (page 162) as required. Install the battery.
6. Perform a pre-ride inspection (page 33), then test-ride your ATV at low speeds.

You & the Environment

Owning and riding an ATV can be enjoyable, but you must do your part to protect nature. When you show respect for the land, wildlife, and other people, you also help preserve the sport of off-road riding.

Following are tips on how you can be an environmentally-responsible ATV owner.

- **Tread Lightly.** Stay on existing roads and trails, avoid surfaces that are easily damaged, and ride only in areas approved for off-road vehicles.
- **Keep the Noise Down.** Loud vehicles can be offensive. Ride as quietly as possible, don't remove your spark arrester, and don't modify the muffler or any other part of your air intake and exhaust systems. Such modifications not only increase noise, they also reduce engine performance and may be illegal.
- **Choose Sensible Cleaners.** Use a biodegradable detergent when you wash your ATV. Avoid aerosol spray cleaners that contain chlorofluorocarbons (CFCs) which damage the atmosphere's protective ozone layer. Don't throw cleaning solvents away; see the following guidelines for proper disposal.
- **Recycle Wastes.** It's illegal and thoughtless to put used engine oil in the trash, down a drain, or on the ground. Used oil, gasoline, and cleaning solvents contain poisons that can hurt refuse workers and contaminate our drinking water, lakes, rivers, and oceans. Before changing your oil, make sure you have the proper containers. Put oil and other toxic wastes in separate sealed containers and take them to a recycling center. Call your local or state office of public works or environmental services to find a recycling center in your area, and to get instructions on how to dispose of non-recyclable wastes.

Taking Care of the Unexpected

With all the challenges you can encounter off-road, there's a chance that sometime something may go wrong. This section gives practical advice to help you deal with a wide range of problems. Take time to read this section before you ride. Also review the tips in *Preparing for a Ride* (page 170).

General Guidelines.....	180
If Your Engine Quits or Won't Start.....	182
If You Have a Flat Tire	186
If the High Coolant Temperature Indicator Lights.....	189
If a Fuse Blows (TRX450ER only)	191
If You Crash.....	193
If You Lose Your Key	194
If the Battery Is Low (or Dead) (TRX450ER only).....	195
If a Component Fails.....	196

Taking Care of the Unexpected

General Guidelines

Keeping your ATV well-maintained is the best way to reduce the possibility of having a problem while riding. However, problems can arise even with well-maintained machines.

Remember to take along your owner's manual, the tool kit that came with your ATV, and any other items (such as tire repair supplies and additional tools) that might help you solve a problem on your own.

If something goes wrong during a ride, the first thing to do is stop as soon as you safely can. Do not continue riding if you have a flat tire, or you hear an unusual noise, or your ATV just doesn't feel right. If you continue riding, you could cause more damage and endanger your own safety.

After a stop, take time to assess the situation. Carefully inspect your ATV to identify the problem, then consider your options before you decide what to do.

If a problem is relatively minor and you have the tools, supplies, and skills to make a permanent repair, you may be able to fix it on the trail and continue riding. Or, you may be able to make a temporary repair that allows you to slowly ride back to your base where you can make a permanent repair or get help.

When a problem is more serious—or you don't have the tools, supplies, experience, or time to deal with it—you need to choose the safest way to get yourself and your ATV back to base. For example, if you are close enough, you (or you and another person) might be able to push it back.

Taking Care of the Unexpected

Should you ever have a problem while riding, please follow these guidelines:

- Always put personal safety first.
- Take time to assess the situation and your options before deciding what to do.
- If the problem is relatively minor and you have the tools, supplies, and skills to make a temporary repair, be sure to have permanent repairs made as soon as possible.
- Do not continue riding if you are hurt or your ATV is not in safe riding condition.

Additional recommendations for specific problems follow.

If Your Engine Quits or Won't Start

Proper operation and maintenance can prevent starting and engine performance problems. In many cases, the cause of the problem may be a simple operational oversight.

If you have a problem starting the engine — or experience poor engine performance — the following information may help you. If you can't correct the problem, see your Honda dealer.

(TRX450ER)

If your ATV won't start, listen as you press the start button. If you don't hear the starter motor turning, refer to the *Starter motor doesn't operate* symptom. If you can hear the starter motor working normally, refer to the *Starter motor works, but the engine won't start* symptom.

(TRX450R)

If your ATV won't start, refer to the *Engine doesn't operate* symptom.

If Your Engine Quits or Won't Start

SYMPTOM: Starter motor doesn't operate. (TRX450ER only)	
POSSIBLE CAUSE	WHAT TO DO
ignition switch OFF	Turn the ignition switch ON.
transmission not in neutral	Shift into neutral.
blown fuse	Replace with a new fuse of the same rating (page 191).
battery lead loose	Tighten the battery lead.
low (or dead) battery	Charge the battery (page 162). If charging doesn't help, see your Honda dealer.
faulty starter motor	If all possible causes are negative, the starter motor may be faulty. See your Honda dealer.

SYMPTOM: Starter motor works, but the engine won't start. (TRX450ER only)	
POSSIBLE CAUSE	WHAT TO DO
engine stop switch OFF	Turn the engine stop switch to RUN.
out of fuel	Fill the fuel tank.
flooded engine	See <i>Flooded Engine</i> (page 54).
loose or unconnected spark plug cap	Install the spark plug cap securely. If the engine still won't start, see your Honda dealer.
not enough throttle freeplay	Check the throttle freeplay (page 114).
loose battery cables	Tighten the battery terminal bolts.
weak battery	Charge the battery (page 162). If charging doesn't help, see your Honda dealer.

If Your Engine Quits or Won't Start

SYMPTOM: Engine doesn't operate. (TRX450R only)	
POSSIBLE CAUSE	WHAT TO DO
ignition switch OFF	Turn the ignition switch ON.
engine stop switch OFF	Turn the engine stop switch to RUN.
transmission not in neutral	Shift into neutral.
out of fuel	Fill the fuel tank.
flooded engine	See <i>Flooded Engine</i> (page 54).
loose or unconnected spark plug cap	Install the spark plug cap securely. If the engine still won't start, see your Honda dealer.
not enough throttle freeplay	Check the throttle freeplay (page 114).

If Your Engine Quits or Won't Start

SYMPTOM: Engine starts, but runs poorly.	
POSSIBLE CAUSE	WHAT TO DO
idles roughly, too fast, stalls	Check engine idle adjustment (page 120). If the problem persists, see your Honda dealer.
improperly throttle freeplay	Check the throttle freeplay (page 114).
poor engine performance at altitudes above 4,500 feet (1,500 m).	Ask your Honda dealer to modify the carburetion with a high altitude jet. Refer to <i>High Altitude Carburetor Adjustment</i> , page 206.
high coolant temperature	Check the high coolant temperature indicator. Refer to <i>If the High Coolant Temperature Indicator Lights</i> , page 189.
runs erratically, misfires	See your Honda dealer.
blubbers (rich fuel mixture)	See your Honda dealer.
sooty exhaust (rich fuel mixture)	See your Honda dealer.
detonates or pings under load	If applicable, switch to the recommended octane gasoline (page 89) or change your brand of gasoline. If the problem persists, see your Honda dealer.
afterfires (backfires)	See your Honda dealer.
pre-ignition (runs on after ignition switched OFF)	See your Honda dealer.

If You Have a Flat Tire

How you handle a flat tire on the trail depends on how serious the tire damage is, and what tools and supplies you have with you.

If you have a slow leak or a minor puncture, use the plug method to make a temporary repair. (The plug method is applied from the outside of the tire and is the same as that for conventional tubeless tires.)

A plug-type repair kit, available at most auto parts stores or service stations, provides a plug, an installation tool, tire cement, and an instruction sheet. Follow the instructions provided with the repair kit to make a temporary repair.

As soon as possible, have the tire permanently repaired by your Honda dealer. Any tire that cannot be repaired should be replaced.

Whenever the ATV is to be operated far from service facilities or available transportation, we recommend that you carry a tire pump and a repair kit with the vehicle.

If the leak is more serious, or a temporary repair doesn't hold, the tire must be replaced. The tire will also need to be replaced if it is damaged (page 149). Replacing a tire involves removing and re-installing the wheel (page 187).

If you are unable to repair a flat tire on the trail, you will need to send for help. We strongly recommend that you do not try to ride with a flat tire. The ATV will be hard to handle, and if the tire comes off the rim, it may lock up the wheel and cause you to crash.

If You Have a Flat Tire

Emergency Wheel Removal/Installation

Refer to *Safety Precautions* on page 77 .

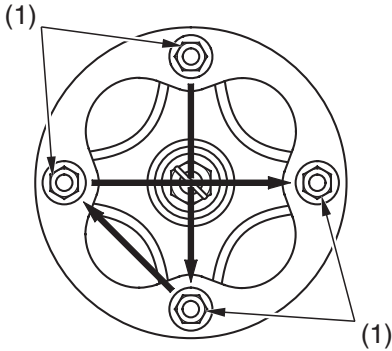

(1) wheel nuts

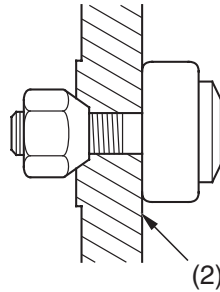

(2) wheel rim

Removal

1. Park your ATV on a firm, level surface.
2. Raise the front (or rear) wheels off the ground and place a support block under the vehicle.
3. Remove the wheel nuts (1).
4. Remove the wheel.
 - Avoid getting grease, oil, or dirt on the disc or pad surfaces when removing and installing each wheel. Any contamination can cause poor brake performance or rapid pad wear after reassembly.

If You Have a Flat Tire

Installation

1. Position the wheel.
2. Position the wheel nuts so that the tapered sides face the wheel rim (2).
3. Tighten the wheel nuts in a crisscross (rather than a circular) pattern to the specified torque:
47 lbf·ft (64 N·m , 6.5 kgf·m)

If a torque wrench was not used for installation, see your Honda dealer as soon as possible to verify proper assembly. Improper assembly may lead to loss of braking capability.

If the High Coolant Temperature Indicator Lights

(TRX450ER)

Normally, the high coolant temperature indicator will only light momentarily when you turn the ignition ON (I).

(TRX450R)

Normally, the high coolant temperature indicator will only light momentarily when you start and running the engine.

Occasionally, it may flicker at or near idling speed.

High coolant temperature may be caused by restriction of air flow to the radiator (such as mud caked on the radiator), extended idling, an oil leak, a coolant leak, a low oil level, a low coolant level, or extended operation under adverse conditions.

If the indicator comes on while you're riding, don't ignore it. Pull safely to a stop. Stop the engine as soon as it's safe to do so, and let it cool.

NOTICE

Continuing to ride with high coolant temperature or an overheated engine can cause serious engine damage.

- A steaming engine indicates a coolant leak. Shut the engine off and wait until the steaming stops. Look for a leak, but don't touch the engine or radiator system. Let everything cool off first.
- Check for any restriction of air flow through the radiator.
- If there's no obvious problem, leave the engine on so the fan and coolant circulating system can continue working. Monitor the high coolant temperature indicator. The indicator may turn off after a brief stop with no load on the engine.
- Check the radiator fan. If the fan is not working, have your Honda dealer check for problems. If the radiator fan is working, visually check the coolant level in the reserve tank, located under the steering cover. It isn't necessary to touch the radiator system.

(cont'd)

If the High Coolant Temperature Indicator Lights

- If the reserve tank is low or empty, don't ride without adding coolant (page 105). After adding coolant, turn the engine on and check the high coolant temperature indicator.

If the indicator doesn't turn off, do not ride. The engine needs repair. Transport your ATV to a Honda dealer (page 172).

If the temperature drops to normal, check the coolant level. If it has gone down, add more coolant.

- Check for an oil leak.
- Check the oil level. If necessary, add the recommended oil (page 95) to the upper level mark. If you must leave your ATV to get oil, secure it as much as possible.
- Start the engine, and check that the high coolant temperature indicator goes off.

If the indicator goes off — resume riding. If there is a leak — do not ride the ATV until the leak is repaired by a Honda dealer.

If there's a mild coolant leak, you can ride for awhile, carefully watching the indicator. Be prepared to stop and add more coolant or water. If the leak is bad, transport your ATV to a Honda dealer (page 172).

If a Fuse Blows (TRX450ER only)

All of the electrical circuits on your ATV have a fuse to protect them from damage caused by excess current flow (short circuit or overload).

If something electrical on your ATV stops working, the first thing you should check for is a blown fuse (1).

Check the fuse before looking elsewhere for another possible cause of the problem. Replace a blown fuse and check component operation.

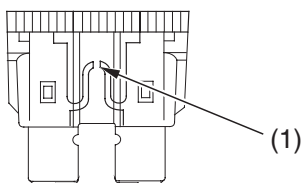

(1) blown fuse

The main fuse is located near the battery.

Recommended Fuse

main fuse	15 A
-----------	------

If a Fuse Blows (TRX450ER only)

Main Fuse Access

INSIDE THE BATTERY COVER

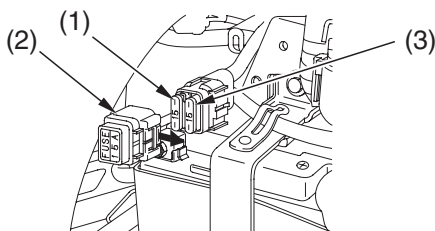

(1) main fuse

(3) spare main fuse

(2) fuse case cover

1. To prevent an accidental short circuit, turn the ignition switch OFF (\circ) before checking or replacing the fuse.
2. To access the main fuse (1), remove the battery cover (page 160).
3. Remove the fuse case cover (2).
4. Pull the main fuse out.

If it is blown, install the spare main fuse (3).

If you do not have a replacement fuse with the proper rating for the circuit, install one with a lower rating.

NOTICE

Replacing a fuse with one that has a higher rating greatly increases the chance of damage to the electrical system.

5. Reinstall the fuse case cover.
6. Install the battery cover.

If the replacement fuse of the same rating burns out in a short time, there is probably a serious electrical problem on your ATV. Leave the blown fuse in that circuit and have your ATV checked by your Honda dealer.

If You Crash

Personal safety is your first priority after an accident. If you or anyone else has been injured, take time to assess the severity of the injuries and whether it is safe to continue riding. If you cannot ride safely, send someone for help. Do not ride if you will risk further injury.

If you decide you are capable of riding safely, carefully inspect your ATV for damage and determine if it is safe to ride. Check the tightness of critical nuts and bolts securing such parts as the handlebar, control levers, brakes, and wheels.

If there is minor damage, or you are unsure about possible damage but decide to try riding the ATV back to your base, ride slowly and cautiously.

Sometimes, crash damage is hidden or not immediately apparent. When you get home, thoroughly check your ATV and correct any problems you find. Also, be sure to have your Honda dealer check the frame and suspension after any serious crash.

If You Lose Your Key

Be sure to record your key number (1) in the Quick Reference section at the rear of the manual. You'll need this number to have a duplicate key made.

If you lose your key and aren't carrying a duplicate, either get your spare or have one made. If you don't know your key number, call the dealer where you purchased your Honda ATV. They may have it listed in their records. If they don't, transport your ATV to them or the nearest Honda dealer. The dealer will probably have to remove the ignition switch assembly to find the key number so they can make a key for you.

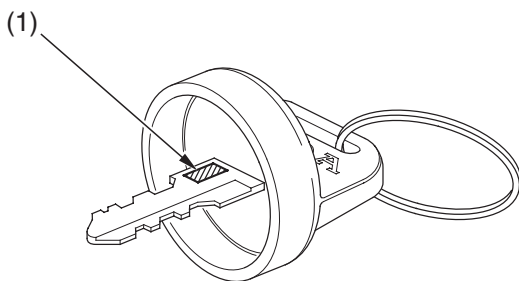

(1) key number

If the Battery Is Low (or Dead) (TRX450ER only)

Jump starting is not recommended, especially if you use an automobile battery. The greater amperage of an automobile battery when the car engine is running can damage your ATV's electrical system.

Bump starting is also not recommended.

If you can't charge the battery or it appears unable to hold a charge, contact your Honda dealer.

If a Component Fails

The levers or pedal, control cables, and other components can be damaged as you ride in dense brush or over rocky terrain. Making a trailside repair depends on how serious the damage is and what tools and supplies you have with you.

- If any component of the brake system is damaged, you may be able to ride carefully back to your base using the other brake components for slowing or stopping.
- If you damage a throttle cable or other critical component, your ATV may be unsafe to ride. Carefully assess the damage and make any repairs that you can. But if there is any doubt, it's best to be conservative and safe.

Technical Information

This section contains dimensions, capacities, and other technical data, plus information on government requirements and how to break-in your ATV.

Vehicle Identification.....	198
Specifications	200
Break-in Guidelines	205
High Altitude Carburetor Adjustment	206
Emission Control Systems.....	207
Oxygenated Fuels.....	211

Vehicle Identification

Serial Numbers

The VIN, engine serial number, and key number may be required when ordering replacement parts. You may record these numbers in the Quick Reference section at the rear of this manual.

The VIN (1) is stamped on the front of the frame.

FRONT

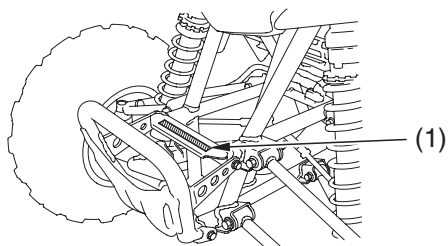

(1) VIN

The engine number (2) is stamped on the left side of the crankcase.

LEFT SIDE

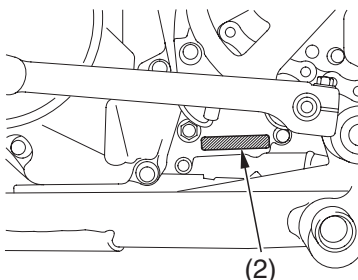

(2) engine number

Vehicle Identification

Color Label & Code

The color label (1) is attached to the front of the frame.

The color code is helpful when ordering replacement parts. You may record the color and code in the Quick Reference section at the rear of this manual.

LEFT FRONT

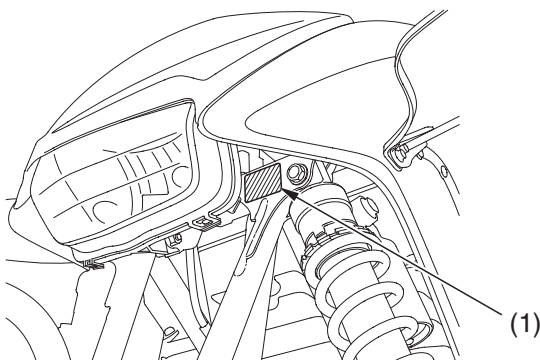

(1) color label

Specifications

Dimensions	
overall length	73.3 in (1,862 mm)
overall width	46.3 in (1,177 mm)
overall height	43.3 in (1,100 mm)
wheelbase	50.2 in (1,275 mm)
ground clearance	4.4 in (111 mm)

Fuel & Lubricants	
fuel recommendation	premium unleaded gasoline, pump octane number of 91 or higher
fuel tank capacity	2.72 US gal (10.3 l) including reserve
fuel tank reserve	0.79 US gal (3.0 l)
engine oil capacity	after disassembly: 0.90 US qt (0.85 l) after draining: 0.69 US qt (0.65 l) after draining & oil filter change: 0.73 US qt (0.69 l)
engine oil recommendation	API Service Classification SG or higher except oils labeled as energy conserving on the circular API service label, SAE 10W-30, JASO T 903 standard MA, Pro Honda GN4 4-stroke oil (USA & Canada) or Honda 4-stroke oil (Canada only), or an equivalent motorcycle oil

Specifications

Fuel & Lubricants (cont'd)	
transmission oil capacity	after disassembly: 0.85 US qt (0.80 ℓ) after draining: 0.72 US qt (0.68 ℓ)
transmission oil recommendation	API Service Classification SG or higher except oils labeled as energy conserving on the circular API service label, SAE 10W-30, JASO T 903 standard MA, Pro Honda HP Trans Oil, Pro Honda GN4 4-stroke oil, or an equivalent.
cooling system recommendation	Pro Honda HP Coolant or an equivalent high quality ethylene glycol antifreeze containing corrosion protection inhibitors specifically recommended for use in aluminum engines
cooling system capacity	1.6 US qt (1.5 ℓ)

Specifications

Capacities	
passenger capacity	operator only
maximum weight capacity	243 lbs (110 kg) rider, all cargo and accessories

Engine Specifications	
displacement	27.4 cu-in (449 cm ³)
bore & stroke	3.78 × 2.44 in (96.0 × 62.1 mm)
compression ratio	12.0 : 1
spark plug (standard)	IFR7L11 (NGK) or VK22PRZ11 (DENSO)
spark plug (high speed riding)	IFR8H11 (NGK) or VK24PRZ11 (DENSO)
spark plug gap	0.039 – 0.043 in (1.0 – 1.1 mm)
valve clearance (cold)	intake: 0.006 in (0.16 mm) exhaust: 0.011 in (0.28 mm)
idle speed	1,700 ± 100 rpm

Power Transmission		
primary reduction		2.739
final reduction		2.923
gear ratio	1st	2.230
	2nd	1.785
	3rd	1.437
	4th	1.181
	5th	0.962
final drive		chain DID520V or RK520 SMOZ10S

Specifications

Chassis & Suspension	
caster	5°
trail	0.9 in (23 mm)
tire size, front	AT21 × 7R10 ★★ DUNLOP KT331H
tire size, rear	AT20 × 10R9 ★★ DUNLOP KT355H
tire pressure, front & rear (cold)	Front: 4.0 psi (27.5 kPa , 0.275 kgf/cm ²) Rear: 4.7 psi (32.5 kPa , 0.325 kgf/cm ²)

Specifications

Electrical	
battery (TRX450ER only)	12 V – 6 Ah
generator	0.214 kW/5,000 rpm

Lights	
headlight	12 V 30/30 W × 2
brake/tail light	LED
high coolant temperature indicator	12 V 3.4 W
neutral indicator (TRX450ER only)	12 V 3 W

Fuse	
main (TRX450ER only)	15 A

Torque Specification	
engine oil drain bolt	18 lbf·ft (25 N·m , 2.5 kgf·m)
oil filter cover bolts	9 lbf·ft (12 N·m , 1.2 kgf·m)
transmission oil drain bolt	16 lbf·ft (22 N·m , 2.2 kgf·m)
transmission oil check bolt	9 lbf·ft (12 N·m , 1.2 kgf·m)
wheel nuts	47 lbf·ft (64 N·m , 6.5 kgf·m)

Break-in Guidelines

Help assure your ATV's future reliability and performance by paying extra attention to how you ride during the first operating day or 15 miles (25 km).

During this period, avoid full-throttle starts, rapid acceleration, and constant rpm operation.

High Altitude Carburetor Adjustment

At high altitude, the standard carburetor air-fuel mixture will be too rich. Performance will decrease, and fuel consumption will increase. A very rich mixture will also foul the spark plug and cause hard starting. Operation at an altitude that differs from that at which this engine was certified, for extended periods of time, may increase emissions.

High altitude performance can be improved by specific modifications to the carburetor. If you always operate your engine at altitudes above 6,500 feet (2,000 meters), have your servicing dealer perform this carburetor modification. This engine, when operated at high altitude with the carburetor modifications for high altitude use, will meet each emission standard throughout its useful life.

Even with carburetor modification, engine horsepower will decrease about 3.5% for each 1,000-foot (300-meter) increase in altitude. The effect of altitude on horsepower will be greater than this if no carburetor modification is made.

NOTICE

When the carburetor has been modified for high altitude operation, the air-fuel mixture will be too lean for low altitude use. Operation at altitudes below 5,000 feet (1,500 meters) with a modified carburetor may cause the engine to overheat and result in serious engine damage. For use at low altitudes, have your servicing dealer return the carburetor to original factory specifications.

Emission Control Systems

Exhaust Emission Requirements

The U.S. Environmental Protection Agency (EPA), the California Air Resources Board (CARB), and Environment Canada (EC) require that your ATV comply with applicable exhaust emissions standards during its useful life, when operated and maintained according to the instructions provided.

The Vehicle Emission Control Information Label (1) (2) is attached on the front of the frame.

FRONT

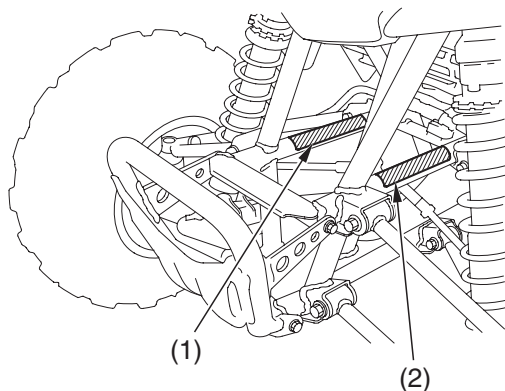

- (1) vehicle emission control information label
- (2) vehicle emission control information label (Canada only)

Emission Control Systems

Source of Exhaust Emissions

The combustion process produces carbon monoxide (CO), oxides of nitrogen (NO_x) and hydrocarbons (HC). Control of hydrocarbons and oxides of nitrogen is very important because, under certain conditions, they react to form photochemical smog when subjected to sunlight. Carbon monoxide does not react in the same way, but it is toxic.

Honda Motor Co., Ltd. utilizes various systems to reduce carbon monoxide, oxides of nitrogen and hydrocarbons.

Exhaust Emission Control System

The exhaust emission control system is composed of appropriate carburetor settings. No adjustments should be made except for an idle speed adjustment with the throttle stop screw or carburetor adjustment for high altitude operation.

The exhaust emission control system is separate from the crankcase emission control system.

Emission Control Systems

Crankcase Emission Control System

The engine is equipped with a closed crankcase system to prevent discharging crankcase emissions into the atmosphere. Blow-by gas is returned to the combustion chamber through the air cleaner and the carburetor.

Problems That May Affect ATV Exhaust Emissions

If you are aware of any of the following symptoms, have the vehicle inspected and repaired by your Honda ATV dealer.

Symptoms:

1. Hard starting or stalling after starting
2. Rough idle
3. Misfiring or backfiring during acceleration
4. After-burning (backfiring)
5. Poor performance (driveability) and poor fuel economy

Federal regulations prohibit removing or disabling a device or element of design that may affect your engine's emission performance unless your ATV will be used exclusively in competition. If you modify your engine for use in sanctioned competition events, you must deface or destroy the emission control information label.

Emission Control Systems

Noise Emission Control System

TAMPERING WITH THE NOISE CONTROL SYSTEM IS PROHIBITED:

State laws prohibit, or Canadian provincial laws may prohibit the following acts or the causing thereof: (1) The removal or rendering inoperative by any person, other than for purposes of maintenance, repair or replacement, of any device or element of design incorporated into any new vehicle for the purpose of noise control prior to its sale or delivery to the ultimate purchaser or while it is in use; or (2) the use of the vehicle after such device or element of design has been removed or rendered inoperative by any person.

AMONG THOSE ACTS PRESUMED TO CONSTITUTE TAMPERING ARE THE FOLLOWING ACTS:

1. Removal of, or puncturing the muffler, baffles, header pipes or any other component which conducts exhaust gases.
2. Removal of, or puncturing of any part of the intake system.
3. Lack of proper maintenance.
4. Replacing any moving parts of the vehicle, or parts of the exhaust or intake system, with parts other than those specified by the manufacturer.

Fuel Permeation Emission Control System

This vehicle complies with the Fuel Permeation Emission Control regulations of the U.S. Environmental Protection Agency (EPA), the California Air Resources Board (CARB), and Environment Canada (EC).

The fuel tank, fuel hoses, and fuel vapor charge hoses used on this vehicle incorporate fuel permeation control technologies.

Tampering with the fuel tank, fuel hoses, or fuel vapor charge hoses to reduce or defeat the effectiveness of the fuel permeation technologies is prohibited by federal regulations.

Oxygenated Fuels

Some conventional gasolines are being blended with alcohol or an ether compound. These gasolines are collectively referred to as oxygenated fuels. To meet clean air standards, some areas of the United States and Canada use oxygenated fuels to help reduce emissions.

If you use an oxygenated fuel, be sure it is unleaded and meets the minimum octane rating requirement.

Before using an oxygenated fuel, try to confirm the fuel's contents. Some states/provinces require this information to be posted on the pump.

The following are the EPA-approved percentages of oxygenates:

ETHANOL (ethyl or grain alcohol) 10% by volume

You may use gasoline containing up to 10% ethanol by volume.

Gasoline containing ethanol may be marketed under the name "Gasohol".

MTBE (Methyl Tertiary Butyl Ether) 15% by Volume

You may use gasoline containing up to 15% MTBE by volume.

METHANOL (methyl or wood alcohol) 5% by Volume

You may use gasoline containing methanol containing up to 5% methanol by volume as long as it also contains cosolvents and corrosion inhibitors to protect the fuel system. Gasoline containing more than 5% methanol by volume may cause starting and/or performance problems. It may also damage metal, rubber, and plastic parts of your fuel system.

Oxygenated Fuels

If you notice any undesirable operating symptoms, try another service station or switch to another brand of gasoline.

Fuel system damage or performance problems resulting from the use of an oxygenated fuel containing more than the percentages of oxygenates mentioned above are not covered under warranty.

Oxygenated fuels can damage paint and plastic. Be careful not to spill fuel when filling the fuel tank. Wipe up any spills immediately.

NOTICE

Oxygenated fuels can damage paint and plastic. Damage caused by spilled fuel is not covered by warranty.

Consumer Information

This section contains information on your warranty and how to get an official Honda service manual.

Authorized Manuals	214
Warranty Coverage	217
Warranty Service.....	218
Contacting Honda	219
Your Honda Dealer	220
The Honda Rider's Club (USA only).....	221

Authorized Manuals

The Service Manual used by your authorized Honda dealer is available from Helm, Inc. (USA only, Canada: See your Honda dealer to order authorized manuals.)

Also available but not necessary to service your model is the Honda Common Service Manual which explains theory of operation and basic service information for various systems common to all Honda motorcycles, motor scooters and ATVs.

These Honda manuals are written for the professional technician, but most mechanically-capable owners should find them easy to use if they have the proper tools and observe proper safety standards. Special Honda tools are necessary for some procedures.

Publication Item No.	Description	Price Each*
61HP104	2008 TRX450ER/R Service Manual	\$48.00
61CM002	Common Service Manual	\$48.00
31HP1640	2008 TRX450ER/R Owner's Manual	\$16.00

** Prices are subject to change without notice and without incurring obligation.*

Order On-Line: www.helminc.com

Order Toll Free: 1-888-CYCLE93 (1-888-292-5393)

(NOTE: For Credit Card Orders Only)

Monday — Friday 8:00 AM — 6:00 PM EST

OR

By completing this form you can order the materials desired. You can pay by check or money order, or charge to your credit card. Mail to Helm, Inc. at the address shown on the back of this order form (USA only).

Canada: See your Honda dealer to order authorized manuals.

Publication Item No.	Item Description	Qty.	Price Each*	Total Price
*Prices are subject to change without notice and without incurring obligation. Orders are mailed within 10 days. Please allow adequate time for delivery.		Sub Total		
		Purchaser's Sales Tax		
		Mich. Add 6 %		
		Calif. Add 8.25 %		
		Handling Charge		\$5.00
		Grand Total		

S
H
I
P
T
O

NOTE: Dealers and Companies please provide dealer or company name, and also the name of the person to whose attention the shipment should be sent.

Customer Name _____

Attention _____

Street Address _____ Apartment Number _____

City _____ State _____ Zip Code _____

Daytime Telephone Number () _____

P
A
Y
M
E
N
T

Check or money order enclosed payable to Helm Inc. U. S. funds only. Do not send cash.

Check here if your billing address is different from the shipping address shown above.

VISA MasterCard Discover

Account Number

Expiration: Mo. Yr.

—

Customer Signature _____ Date _____

These Publications cannot be returned for credit without receiving advance authorization within 14 days of delivery. On returns, a restocking fee may be applied against the original order.

HELM P. O. BOX 07280, DETROIT, MICHIGAN 48207

Warranty Coverage

Your new Honda is covered by these warranties:

- TRX Limited Warranty
- Exhaust Emission Warranty

There are responsibilities, restrictions, and exclusions which apply to these warranties. Please read the Warranties Booklet given to you by your Honda dealer at the time of purchase. Be sure to keep your Honda owner's card with your Warranties Booklet (USA only).

It is important to realize that your warranty applies to defects in material or workmanship of your Honda. Your warranty coverage does not apply to normal wear or deterioration associated with using the ATV.

Your warranty coverage will not be voided if you choose to perform your own maintenance. However, you should have the proper tools and service information and be mechanically qualified. Failures that occur due directly to improper maintenance are not covered.

Almost all of your warranty coverage can be extended through the Honda Protection Plan (USA only). For more information, see your Honda dealer.

Warranty Service

Please remember that recommended maintenance interval servicing is not included in your warranty coverage. Additionally, your warranty does not apply to the normal wear of items (such as brakes, tires, etc.).

If you believe you have a problem with your ATV, call the service department of your Honda dealer. Make an appointment for an inspection and diagnosis. Remember, as the owner of the ATV, you will be asked to authorize that inspection. Your dealer will give you the results of the inspection. If the problem is covered under warranty, your dealer will perform the warranty repairs for you.

If you have questions about warranty coverage or the nature of the repair, it is best to talk to the service manager of your Honda dealer.

Sometimes, in spite of the best intentions of all concerned, a misunderstanding may occur. If you aren't satisfied with your dealer's handling of the situation, we suggest you discuss your problem with the appropriate member of the dealership's management team. If the problem has already been reviewed with the Service Manager, Parts Manager, Sales Manager, etc., contact the Owner of the dealership or their designated representative.

Contacting Honda

Your owner's manual was written to cover most of the questions you might ask about your Honda. Any questions not answered in the owner's manual can be answered by your Honda dealer. If your dealer doesn't have the answer right away, they will get it for you.

If you have a difference of opinion with your dealer, please remember that each dealership is independently owned and operated. That's why it's important to work to resolve any differences at the dealership level.

If you wish to comment on your experiences with your Honda or with your dealer, please send your comments to the following address (USA only):

Motorcycle Division, American Honda Motor Co., Inc., P.O. Box 2200, Torrance, CA 90509-2200, mailstop: 100-4C-7B, telephone: (866) 784-1870.

Canada: Refer to the Warranties Booklet that was supplied with your vehicle.

Please include the following information in your letter:

- name, address, and telephone number
- product model, year, and VIN
- date of purchase
- dealer name and address

We will likely ask your Honda dealer to respond, or possibly acknowledge your comments directly.

Your Honda Dealer

Once you purchase your new Honda, get familiar with the organization of your Honda dealer so you can utilize the full range of services available.

The service department is there to perform regular maintenance and unexpected repairs. It has the latest available service information from Honda. The service department will also handle warranty inspections and repairs.

The parts department offers Honda Genuine Parts, Pro Honda products, Honda Genuine Accessories (USA only), and Honda accessories and products (Canada only). The same quality that went into your Honda can be found in Honda Genuine replacement parts. You'll also find comparable quality in the accessories and products available from the parts department.

The sales department offers the Honda Protection Plan to extend almost all of your warranty coverage (USA only).

Your Honda dealer can inform you about competition and other riding events in your area. You'll also find that your dealer is a source of information about American Honda's Rider Education Centers and the Honda Rider's Club of America (USA only).

We're sure you'll be as pleased with the service your Honda dealer continues to provide after the sale as you are with the quality and dependability of your Honda.

The Honda Rider's Club (USA only)

You may be eligible for a Honda Rider's Club of America (HRCA) membership with the purchase of your new Honda. You can log on to the HRCA Clubhouse website for details at www.hrca.honda.com.

Table of Contents

The following presents the contents of each section of your owner's manual.

ATV SAFETY	1
Important Safety Information	2
Safety Labels.....	5
INDICATORS & CONTROLS.....	9
Operation Component Locations	10
Indicators.....	13
High Coolant Temperature Indicator	13
Neutral Indicator (TRX450ER only).....	14
Controls & Features	15
Fuel Valve	15
Choke Knob	16
Hot Start Lever (TRX450R only).....	17
Ignition Switch	18
Start Button (TRX450ER only).....	19
Kickstarter (TRX450R only).....	20
Engine Stop Switch.....	21
Headlight Switch.....	22
Headlight Dimmer Switch.....	22
Throttle Lever	23
Clutch Lever/Parking Brake Lever	23
Front Brake Lever	24
Rear Brake Pedal.....	24
Parking Brake.....	25
Flag Pole Bracket	26

Table of Contents

BEFORE RIDING	27
Are You Ready to Ride?	28
Protective Apparel.....	28
Rider Training	30
Age Recommendation	31
No Passengers	31
No Alcohol or Drugs.....	32
Is Your ATV Ready to Ride?.....	33
Pre-ride Inspection	33
Load Limits & Guidelines.....	36
Loading	36
Load Limits	37
Loading Guidellines	38
Accessories & Modifications	39
Accessories.....	39
Modifications	40

Table of Contents

BASIC OPERATION & RIDING	41
Safe Riding Precautions	42
Off-Road Use Only	42
Keep Hands and Feet on Controls	43
Control Speed	44
Use Care on Unfamiliar or Rough Terrain	45
Do Not Perform Stunts	46
Starting & Stopping the Engine	47
Preparation	48
Starting Procedure	50
Flooded Engine	54
How to Stop the Engine	55
Shifting Gears	56
Braking	58
Riding Your ATV	60
Making Turns	60
Skidding or Sliding	62
Riding Up Hills	63
Riding Down Hills	67
Crossing or Turning on Hills or Slopes	68
Riding Over Obstacles	70
Riding Through Water	71
Parking	72

Table of Contents

SERVICING YOUR HONDA	73
<i>Before You Service Your Honda</i>	
The Importance of Maintenance	75
Maintenance Safety	76
Important Safety Precautions	77
Maintenance Schedule	78
Maintenance Record.....	82
 <i>Service Preparations</i>	
Maintenance Component Locations.....	83
Tool Kit.....	86
Owner's Manual Storage.....	87
Seat Removal	88
 <i>Service Procedures</i>	
<u>Fluids & Filters</u>	
Fuel	89
Engine Oil & Filter.....	92
Transmission Oil	99
Coolant.....	104
Air Cleaner	110
 <u>Engine</u>	
Throttle.....	114
Clutch System	116
Engine Idle Speed	120
Spark Plug	121
Valves.....	124
Spark Arrester	125

(cont'd)

Table of Contents

SERVICING YOUR HONDA (cont'd)

Chassis

Suspension	127
Brakes.....	133
Tires	143
Engine Guard & Skid Plates.....	150
Drive Chain.....	151

Electrical

Battery (TRX450ER only).....	158
------------------------------	-----

Appearance Care.....	163
----------------------	-----

TIPS..... 169

Preparing for a Ride	170
What to Take to the Riding Area	170
What to Take on the Trail	171
Transporting Your Honda	172
Storing Your Honda.....	174
Preparation for Storage.....	175
Removal from Storage.....	177
You & the Environment.....	178

TAKING CARE OF THE UNEXPECTED..... 179

General Guidelines.....	180
If Your Engine Quits or Won't Start.....	182
If You Have a Flat Tire	186
If the High Coolant Temperature Indicator Lights.....	189
If a Fuse Blows (TRX450ER only).....	191
If You Crash.....	193
If You Lose Your Key	194
If the Battery Is Low (or Dead) (TRX450ER only).....	195
If a Component Fails.....	196

Table of Contents

TECHNICAL INFORMATION	197
Vehicle Identification.....	198
Specifications.....	200
Break-in Guidelines	205
High Altitude Carburetor Adjustment.....	206
Emission Control Systems.....	207
Oxygenated Fuels.....	211
CONSUMER INFORMATION	213
Authorized Manuals	214
Warranty Coverage	217
Warranty Service.....	218
Contacting Honda	219
Your Honda Dealer	220
The Honda Rider's Club (USA only).....	221
TABLE OF CONTENTS	222
INDEX	228
QUICK REFERENCE	

Index

A

accessories.....	39
age recommendation	31
air cleaner,	
filter.....	110
air pressure,	
gauge.....	86
tire	144
American Honda, contacting.....	219
apparel, protective.....	28
appearance care	163
authorized manuals.....	214

B

battery (TRX450ER only).....	158
brakes,	
brake pad wear	137
cable	141
fluid.....	133
front brake lever.....	24
front brake lever adjustment	138
parking	25
rear brake pedal.....	24
braking	58
break-in guidelines.....	205

Index

C

capacity, fuel.....	90
care, appearance.....	163
cargo, loading and operational guidelines.....	38
choke, knob.....	16
climbing hills.....	63
clutch system.....	116
color label.....	199
compartment, owner's manual.....	87
tool kit.....	86
component fails.....	196
consumer information.....	213
coolant.....	104
crash, if you.....	193
crossing or turning on hills or slopes.....	68
customer service.....	219

Index

D

dimmer switch, headlight 22

E

emission control systems 207

engine,

 flooded 54

 guard 150

 idle speed 120

 number 198

 oil 92

 pinging 89

 starting 47

 stop switch 21

 stopping 55

 won't start 182

environment 178

exhaust system,

 cleaning 34

 purging 125

F

flag pole bracket.....	26
flat tire.....	186
flooded engine.....	54
fuel,	
fill cap	90
oxygenated	211
recommendation	89
refueling	90
reserve fuel supply	90
tank capacity	90
valve.....	15
fuse (TRX450ER only).....	191

Index

G

gap, spark plug	122, 202
gasohol	211
gasoline	89
gear shifting	56

H

headlight dimmer switch	22
headlight switch	22
high altitude carburetor adjustment	206
hills,	
crossing or turning on slopes.....	68
riding down hills	67
riding up hills	63
stopping on hills	65
Honda,	
contacting	219
Rider's Club	221
dealer.....	220
Honda service manual	214

Index

I

identification, vehicle.....	198
idle speed, engine.....	120
ignition switch.....	18
indicators,	
high coolant temperature indicator.....	13, 189
neutral indicator (TRX450ER only).....	14
inspection, pre-ride.....	33

K

key,	
lost.....	194
number.....	194
kickstarter (TRX450R only).....	20
kit, tool.....	86

Index

L

labels, safety.....	5
limit, weight	37
load limits.....	37
loading guidelines	38
lubrication,	
engine oil.....	92
transmission oil	99
drive chain.....	156

M

maintenance,	
component locations.....	83
importance.....	75
precautions	77
record	82
safety.....	76
schedule.....	78
manual, service.....	214
maximum weight limit	37
modifications.....	40

Index

N

neutral indicator (TRX450ER only).....	14
noise emission control system.....	210
numbers, serial	198

O

obstacles, riding over	70
oil,	
engine	92
transmission.....	99
operating controls.....	15
operation component locations.....	10
owner's manual storage.....	87
oxygenated fuels	211

P

parking	72
passenger, no carrying.....	31
pavement, no riding on.....	42
pinging, engine.....	89
plug, spark.....	121
pre-ride inspection.....	33
problems, unexpected.....	179
protective apparel	28

Index

R

removal, seat	88
rider training.....	30
Rider's Club, Honda.....	221
riding,	
basic operations	41
clothing.....	28
precautions	42
preparing for	170
over obstacles.....	70
safety	2
safety precautions.....	42
through water	71

Index

S

safety,	
important precautions.....	77
labels	5
riding precautions.....	42
schedule, maintenance.....	78
seat removal	88
serial numbers	198
service,	
customer	219
manuals	214
warranty	218
shifting gears.....	56
skid plates.....	150
skidding or sliding.....	62
spark arrester	125
spark knock	89
spark plug.....	121
specifications.....	200
stalling on a hill.....	65

(cont'd)

Index

start button (TRX450ER only).....	19
starting,	
engine	47
troubleshooting.....	182
stop switch, engine	21
stopping engine	55
storage,	
ATV	174
owner's manual	87
switch,	
brakelight	140
headlight.....	22
headlight dimmer	22
ignition	18

T

- throttle,
 - cable 114, 115
 - lever..... 23, 114, 115
- tires,
 - air pressure 144
 - flat 186
 - replacing..... 149
 - repairing 148
 - specifications..... 203
 - tread conditions 146, 147
- tool kit 86
- training, rider..... 30
- transporting your ATV 172
- trouble, unexpected 179
- troubleshooting, starting..... 182
- turning,
 - on level ground..... 60
 - on hills or slopes..... 68

Index

V

valve, fuel.....	15
valve clearance.....	124
vehicle identification no. (VIN).....	198

W

warning labels	5
warranty,	
coverage	217
extended	217
service	218
washing your ATV.....	163
water,	
riding through.....	71
weight limit	37
wheel removal	187

Quick Reference

The following is a brief, but important collection of information you need to know about your Honda. You'll also find space to record important notes.

How To Avoid Costly Repairs

The engine of your Honda can be the most expensive component to repair. Proper maintenance, especially the use of the recommended fluids and filters, prevents premature wear and damage.

Frequent causes of costly repairs are:

- Engine oil: insufficient quantity, improper oil.
- Air cleaner: dirty, leaking because of improper installation (poor seal).

Record important information on the following page:

Quick Reference

Engine No.	
VIN	
Ignition Key No.	
Color Label	
Owner's Name	
Address	
City/State	
Phone	
Dealer's Name	
Address	
City/State	
Phone	
Service Mgr.	

Quick Reference











Scheduled Maintenance	Initial: 100 miles (150 km) Regular: every 600 miles (1,000 km)
Pre-ride Inspection	Check the following items each time before you ride (page 33): engine oil, transmission oil, radiator coolant, fuel, tires, drive chain, nuts & bolts, underbody & exhaust system, leaks, loose parts, cables, lights, throttle, brakes, clutch lever/parking brake lever, switches, steering.
Fuel/Capacity	premium unleaded gasoline, pump octane number 91 or higher 2.72 US gal (10.3 ℓ) reserve: 0.79 US gal (3.0 ℓ)
Engine Oil	API Service Classification SG or higher except oils labeled as energy conserving on the circular API service label, SAE 10W-30, JASO T 903 standard MA, Pro Honda GN4 4-stroke oil or equivalent
Transmission Oil	API Service Classification SG or higher except oils labeled as energy conserving on the circular API service label, SAE 10W-30, JASO T 903 standard MA, Pro Honda HP Trans Oil, Pro Honda GN4 4-stroke oil, or an equivalent.
Maximum Weight Capacity	243 lbs (110 kg) rider, all cargo and accessories

Quick Reference

Tires	Front: AT21 × 7R10 ★★ DUNLOP KT331H Rear: AT20 × 10R9 ★★ DUNLOP KT355H
Tire Pressure (cold)	standard tire pressure: Front: 4.0 psi (27.5 kPa , 0.275 kgf/cm ²) Rear: 4.7 psi (32.5 kPa , 0.325 kgf/cm ²)
Spark Plugs	standard: IFR7L11 (NGK) or VK22PRZ11 (DENSO) high speed riding: IFR8H11 (NGK) or VK24PRZ11 (DENSO)
Coolant	ethylene glycol antifreeze (silicate-free) for aluminum engines in 50/50 solution with Pro Honda HP Coolant or an equivalent distilled water
Fuse (TRX450ER only)	15 A

Quick Reference

These symbols are used in Controls & Features section:

SYMBOL	COMPONENT	SEE PAGE
	choke knob	16
	ON – ignition switch	18
	OFF – ignition switch	18
	START button	19
	RUN – engine stop switch	21
	OFF – engine stop switch	21
	ON – headlight switch	22
	OFF – headlight switch	22
	HI – headlight dimmer switch	22
	LO – headlight dimmer switch	22

